

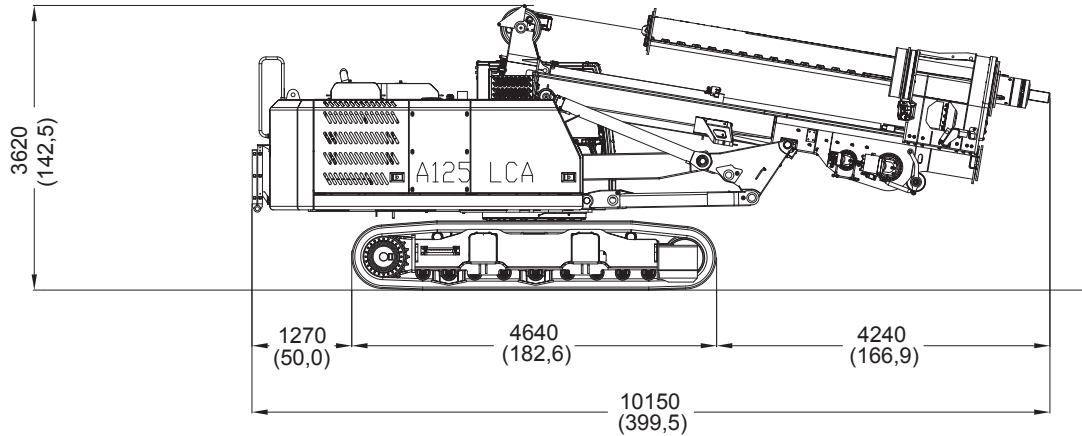

A 125 LCA Powered by CAT



Base		IMT
Undercarriage length / widening range / shoe	mm in	CAT 4620/2550 - 3650/600 182/100 - 144/23,6
Engine type		CAT C 6.6 Acert
Power		120KW (163 HP) @1800 rpm
Rotary		
Installed torque	kNm lbf ft	122 90000
Working speed	rpm	7,5 - 27
Discharge speed	rpm	45 - 120
Winches		
Main winch pull force	kN lbf	123 27655
Main winch speed	m/min ft/min	90 295
Main winch Cable diameter	mm in	22 /
Auxiliary winch pull force	kN lbf	60 13490
Auxiliary winch Speed	m/min ft/min	90 295
Auxiliary winch Cable diameter	mm in	15 /
Crowd system		
Kelly crowd push	kN lbf	100 22485
Kelly crowd pull	kN lbf	165 37095
Stroke	mm in	2000 79
Mast		
Mast raking forward		5°
Mast side raking		+5°
Mast raking backwards		15°
Pile max. diameter	mm in	1500 60
Kelly bar		
Standard		5/17
Options available		
Operating Weight w/standard kelly bar	t lbs	34,55 76170

Measurements in working phase

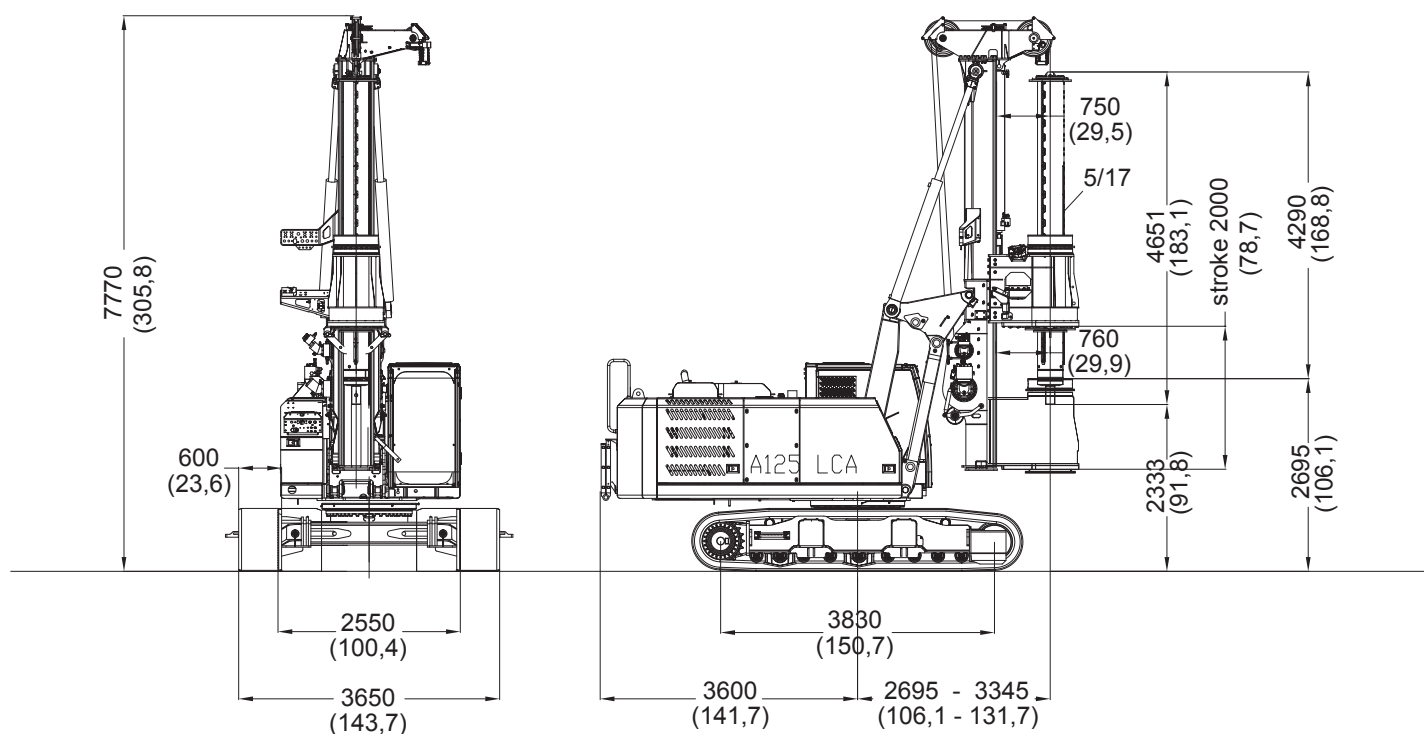

Purpose built Foundation Drilling Rig developed in cooperation with Caterpillar OEM Solutions Group



Via d'Ancona, 39 - 60027 Osimo (An) - Italy
Tel. + 39 071 723341 r.a. - Fax + 39 071 7133352
www.imtspa.com - imt@imtspa.com

All technical data are purely indicative and subject to change without notice.