

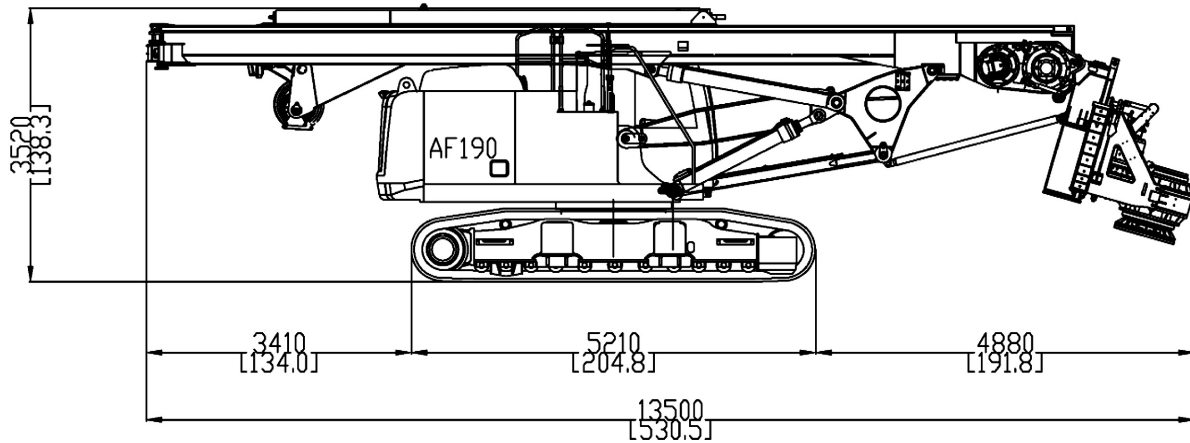

# AF 190

## Powered by CAT



<b>Base</b>		<b>Caterpillar 329E</b>
Undercarriage length / widening range / shoe	mm in	CAT 5210/2900 - 4200/700 205/114 - 165,3/27,5
Engine type		CAT C 7.1
Power		181 kW (245 HP) @1800 rpm
<b>Rotary</b>		
Nominal torque	kNm lbf ft	205 151205
Working speed	rpm	7 - 27
Discharge speed	rpm	40 - 110
<b>Winches</b>		
Main winch pull force	kN lbf	200 44965
Main winch speed	m/min ft/min	85 279
Main winch Cable diameter	mm in	26 /
Auxiliary winch pull force	kN lbf	80 17985
Auxiliary winch Speed	m/min ft/min	85 279
Auxiliary winch Cable diameter	mm in	18 /
<b>Crowd system</b>		
Kelly crowd push	kN lbf	180 40470
Kelly crowd pull	kN lbf	200 44965
Stroke	mm in	5000 197
<b>Mast</b>		
Mast raking forward		5°
Mast side raking		+ 8°
Mast raking backwards		15°
Pile max. diameter	mm in	1800 71
<b>Kelly bar</b>		
Standard		4/42
Options available		4/46 - 4/48 - 5/60
Operating Weight w/standard kelly bar	t (metric) lbs	54 119050

# Measurements in working phase

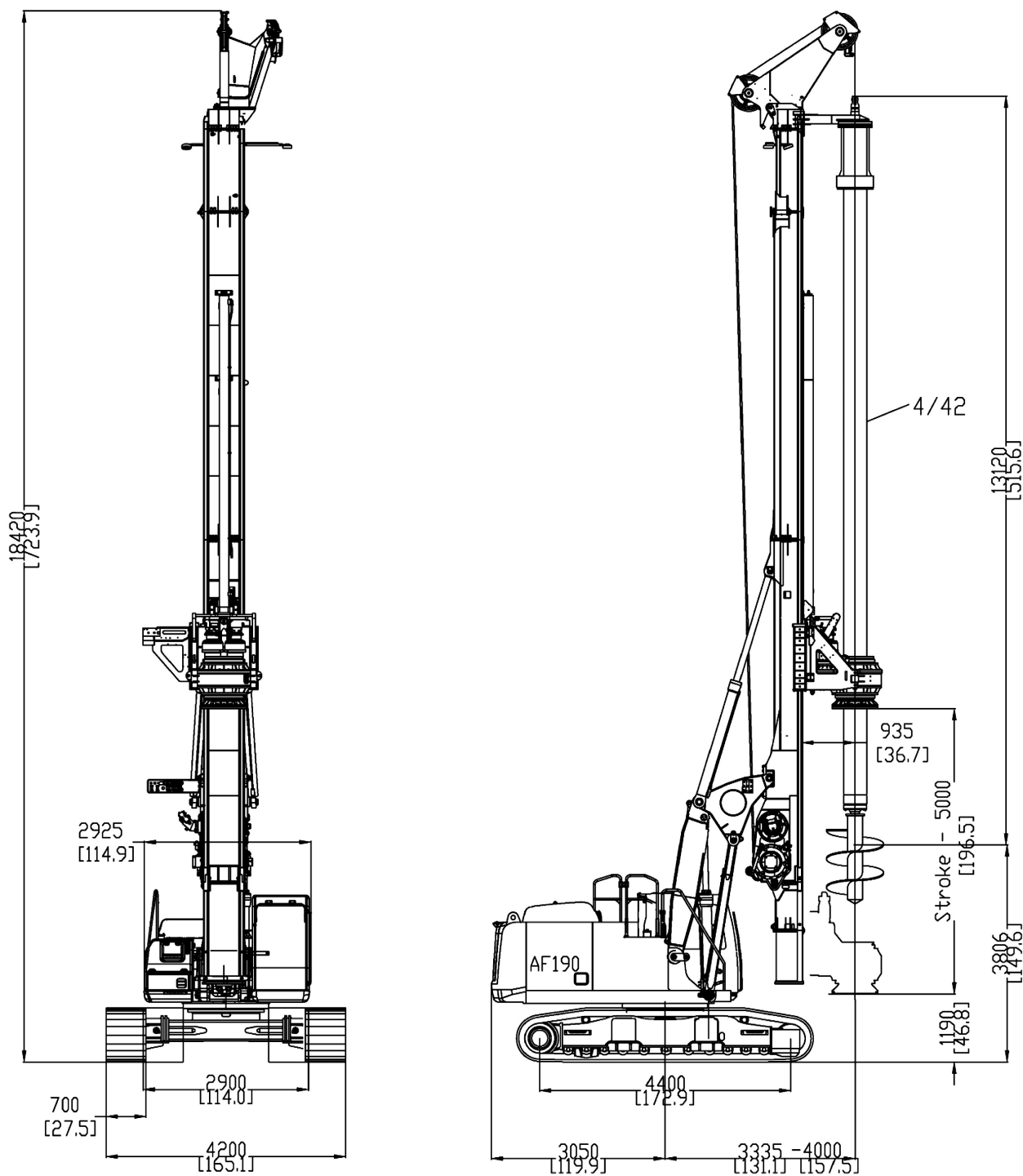

**IMT**  
INTERNATIONAL

**Legal Headquarters:**

Via dei Gracchi, 91 - 00192 Roma Italy

**Offices and Plant:**

Via d'Ancona, 39 - 60027 Osimo (An) - Italy

Tel. + 39 071 723341 r.a. - Fax + 39 071 7133352

www.imtspa.com - imt@imtspa.com

*All technical data are purely indicative and subject to change without notice.*