

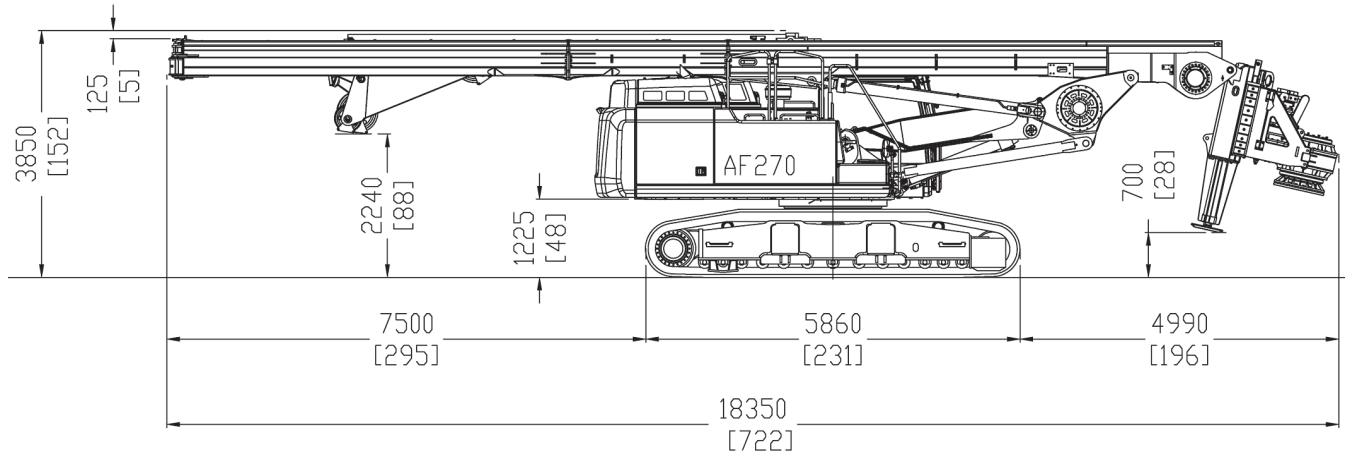

AF 270E



Base

Undercarriage length / widening range / shoe	mm	CAT 349 E
	in	5860/3000 - 4270/720
Engine type		230,7/118 - 168/28,3
Power	Kw	CAT C13 Acert Tier4
		322 KW (432HP) @ 1800rpm

Rotary

Installed torque	kNm	275
	lbf ft	202830
Working speed	rpm	8 - 30
Discharge speed	rpm	48 - 115

Winches

Main winch pull force	kN	250
	lbf	56205
Main winch speed	m/min	73
	ft/min	240
Main winch Cable diameter	mm	28
	in	/
Auxiliary winch pull force	kN	120
	lbf	26980
Auxiliary winch Speed diameter	m/min	80
	ft/min	262
Auxiliary winch Cable diameter	mm	22
	in	/

Crowd system

Kelly crowd push	kN	300
Kelly crowd pull	lbf	67445
	kN	390
Stroke	lbf	87680
	mm	6400
	in	252

Mast

Mast raking forward		5°
Mast side raking		+8°
Mast raking backwards		15°
Pile max. diameter	mm	2000
	in	79

Kelly bar

Standard		4/46
Options available		4/35 - 4/52 - 5/50 - 5/66 - 5/70

Operating Weight w/standard kelly bar	t (metric)	80
	lbs	176368

Measurements in working phase

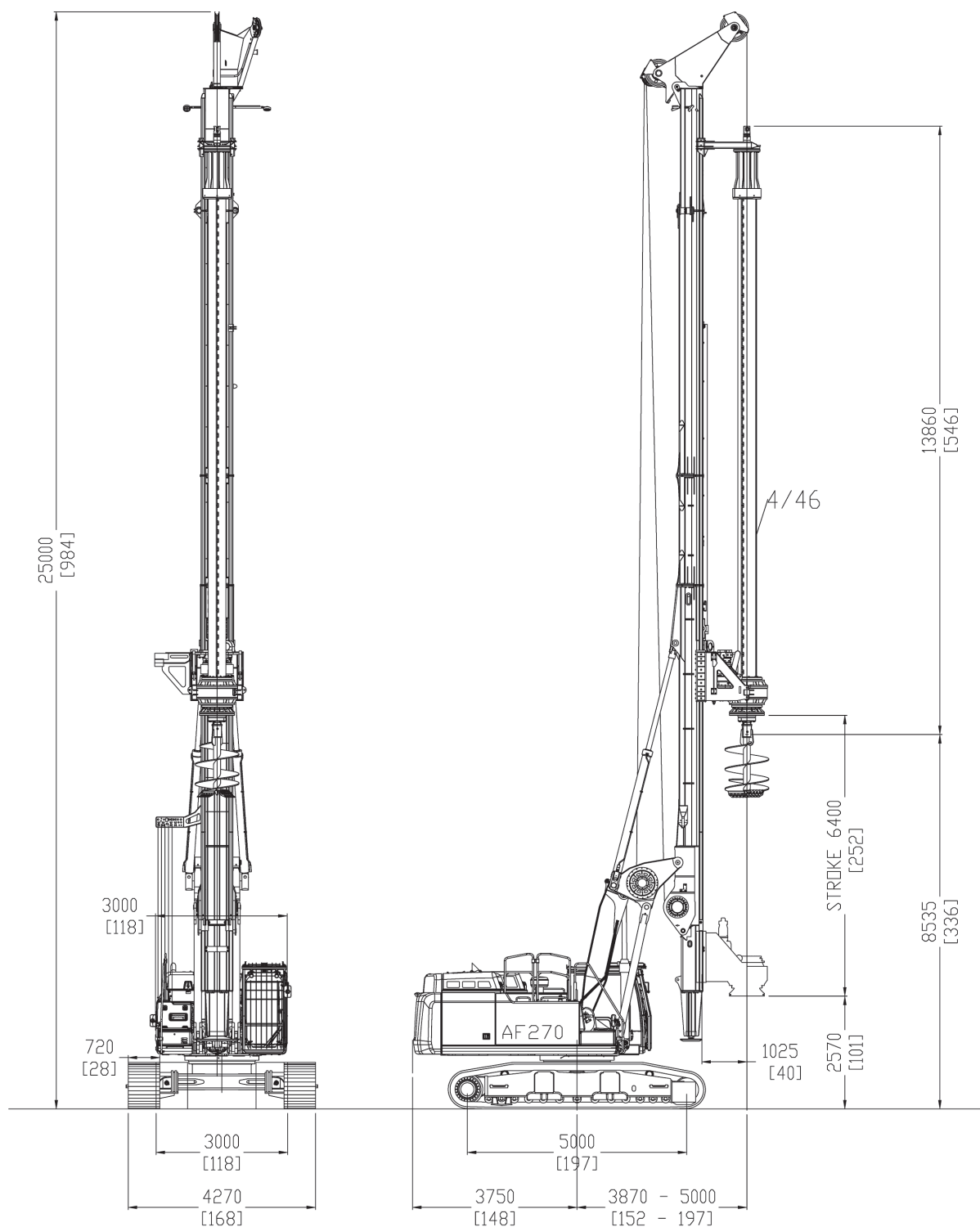

IMT
INTERNATIONAL

Legal Headquarters:
Via dei Gracchi, 91 - 00192 Roma Italy

Offices and Plant:
Via d'Ancona, 39 - 60027 Osimo (An) - Italy

Tel. + 39 071 723341 r.a. - Fax + 39 071 713352
www.imtspa.com - imt@imtspa.com

All technical data are purely indicative and subject to change without notice.