

430E/ 430E IT

Backhoe Loader



Engine

Engine Model	3054C DIT
Gross Power – SAE J1995	75 kW 101 hp
Net Power – SAE J1349	72 kW 97 hp

Weights

Operating Weight – Nominal	7294 kg 16,066 lb
Operating Weight – Maximum	10 700 kg 23,568 lb

Backhoe

Dig Depth – Standard	4698 mm	15 ft 5 in
Dig Depth – Extended	5951 mm	19 ft 6 in

430E/430E IT Backhoe Loader

Caterpillar® Backhoe Loaders set the industry standard for operator comfort, exceptional performance, versatility and jobsite efficiency.

Operator Station

- ✓ The all-new operator station maximizes operator comfort and productivity. Easy to use machine controls keep operator fatigue low and production up throughout the workday. **pg. 4**

Pilot Operated Joystick Controls

- ✓ Standard pilot operated joystick controls are easy to use, reduce operator fatigue and increase efficiency. Auxiliary backhoe hydraulic functions are operated with convenient thumb roller controls. **pg. 6**

Hydraulics

- ✓ Caterpillar's state-of-the-art closed-center hydraulic system, variable displacement piston pump and load-sensing hydraulics improve implement response and speed while still providing high forces at any engine speed. New flow-sharing hydraulic valves improve multi-function performance. **pg. 7**

Work Tools

A new hydraulic thumb is part of the wide range of Cat® Work Tools that are available to meet the needs of your jobsite applications. All machines are equipped with thumb mounting brackets. **pg. 12**

AccuGrade® Reference Systems for Backhoe Loaders

- ✓ Caterpillar is revolutionizing excavation with new technology solutions. The AccuGrade Reference Systems for Backhoe Loaders are entry-level grade and depth check systems that provide accuracy, productivity, lower operating costs and enhanced profitability. **pg. 14**

With standard pilot-operated joystick controls, a more comfortable operator station, new extendible stick design and increased performance, the 430E/430E IT lets you get more done with less effort.



Power Train

- ✓ The Cat® 3054C DIT engine meets all U.S. EPA Tier 2/EU Stage II emissions requirements. The efficient fuel system delivers reliable engine lug performance. The transmission and new Cat axles provide increased roading speed. **pg. 8**

Ride Control

Optional Caterpillar® Ride Control provides a comfortable ride at all speeds, both on the jobsite and on the highway. System is designed to provide an improved ride whether the bucket is full or empty. **pg. 9**

Backhoe and Loader Features

- ✓ New extendible stick is designed for best-in-class performance and digging forces. New wear pad design provides increased life and improved serviceability. Single-tilt or integrated toolcarrier loaders offer solid performance and maximum versatility. **pg. 10**

Additional Features

- ✓ Features such as Product Link, combined function hydraulics, stackable counterweights, new stabilizer pads and new work lights increase productivity and versatility. **pg. 15**

Serviceability and Customer Support

Easier maintenance results in greater machine uptime and lower owning and operating costs. New tilt-up hood provides easier access to the engine compartment. Your Cat dealer offers a wide range of services that can be set up under a Customer Support Agreement. **pg. 16**



✓ *New Feature*

Operator Station

The all-new operator station provides maximum comfort and ease of operation.



430E IT Deluxe Cab

Operator Comfort. The all-new operator station has been designed to maximize operator comfort and productivity. Pilot operated controls allow for more legroom and a spacious work environment.

New Styling. The new ergonomic, automotive styling of the operator station enhances the operator environment. The narrow front dash provides excellent visibility to the front bucket. Integrated storage areas and cupholders are designed for operator convenience.

ROPS Canopy. Features of the ROPS canopy include:

- Air suspension vinyl seat
- Tilt steering wheel
- Two 12-volt internal power supply adapters
- 12-volt external power supply adapter
- Phone clip
- Lockable, left side storage compartment
- Drink holders
- Floor mat
- Eight working lights
- Rotating vandal guard

ROPS Canopy Plus. Includes all of the features of the ROPS canopy with the addition of the following:

- Front windshield
- Wiper/washer system

Standard Cab. The standard cab features include:

- Air suspension fabric seat
- Tilt steering wheel
- Two 12-volt internal power supply adapters
- 12-volt external power supply adapter
- Phone clip
- Lockable, left side storage compartment
- Drink holders
- Floor mat
- Eight working lights
- Two doors
- Front and rear windshield
- Wiper/washer system
- Radio-ready

Deluxe Cab. The deluxe cab includes all of the features of the standard cab plus:

- Deluxe, nine-way adjustable air suspension seat
- Individual auto-up feature on the stabilizer controls
- System indicators for hydraulic filter service and hydraulic temperature warning

Deluxe Cab with Air Conditioning.

Includes all of the features of the deluxe cab with the addition of air conditioning.

New Gauge Cluster. Operators can easily view system information on the new gauge cluster. Gauges are easy to read displays against a white background for good visibility in different light conditions.

Air Suspension Seat. The standard air suspension seat utilizes an air adjustment mechanism for a greater operating range and more comfortable ride. A switch on the side control allows the seat to be tailored to support differing body weights. Adjustable seat height accommodates all operators.

The deluxe cab air suspension seat also has an adjustable back support, lumbar support, seat cushion extension, seat cushion tilt and vertical and angle adjusting armrests.

HVAC System. The improved air conditioning system features enhanced air distribution and performance for a more comfortable work environment. Large capacity fresh air filter is easily serviced from ground level with no tools required. Nearly 20% increase in air flow combined with improved louver locations provide superior operator comfort.



Storage Compartment. New lockable, left side storage compartment is standard on the 430E.

Pilot Operated Joystick Controls

Low effort, comfortable controls reduce fatigue and provide more legroom.



Joystick Controls. Standard excavator-style joysticks provide smooth modulation and are ergonomically designed for low effort control and operator comfort. They also provide increased legroom and greater rearward viewing area.

Pilot Operated Stabilizer Controls. Stabilizer controls are within easy reach of the operator when operating the backhoe and provide low effort and fine modulation control.

Pilot Control Pods. Located on the left and right sides, the controls can move fore and aft and can be operated in either position for maximum comfort.



Joystick Roller Switches. Thumb rollers on the joystick provide convenient, fingertip control of auxiliary functions for features such as the extendible stick, hammers and augers. Roller switches eliminate the need for foot pedals, providing additional foot room for the operator.



Pattern Selector Switch. The pattern selector switch, located in the cab, allows the operator to change from excavator control pattern to backhoe loader control pattern simply by pressing a button.

Hydraulics

Caterpillar sets the standard in power and precision with load-sensing hydraulics.

Load-Sensing Hydraulic System.

The variable displacement piston pump and flow-sharing hydraulic valves sense work demand and adjust flow and pressure for increased productivity. Load-sensing hydraulics deliver:

- Cooler hydraulic system
- Better fuel efficiency
- Quieter operation
- Reduced wear on components

Hydraulic Pump. The variable displacement piston pump improves implement response and speed while still providing high forces at any engine speed.

Torque Limiter Control. The pump torque limiter control manages distribution of engine power to the hydraulic system and drive train. E-Series improvements produce more aggressive backhoe digging and stronger truck loading performance.

Flow-Sharing Hydraulic Valves.

New flow-sharing hydraulic valves automatically distribute flow to optimize multi-function implement performance. Closed-center implement valves signal hydraulic system requirements to a control valve located on the pump.

Clamps and Bushings. Metal clamps with rubber bushings are used at hose attachment points to eliminate metal-to-metal contact and increase wear life.



Cat XT-3 ES ToughGuard™ Hoses.

Improved bend radius and abrasion resistance provide reliable long life in the toughest conditions. Made of four overlapping, insulated wire spiral wraps bonded together for durability, Cat XT-3 ES (Enhanced Spiral) ToughGuard hoses exceed SAE certification standards. The hose routing protects them from work damage, and hose failure is substantially reduced. Cat XT-3 ES ToughGuard hoses combined with Cat couplings and O-ring face seal fittings provide a leak-free system. All backhoe hydraulic circuits utilize the new ToughGuard hose with extended wear characteristics.

Power Train

The Cat 3054C DIT engine is built for performance, power, reliability and fuel efficiency.



3054C DIT Diesel Engine. The 3054C DIT (Direct Injection Turbocharged) engine meets all U.S. EPA Tier 2/EU Stage II emissions requirements. It delivers high horsepower, increased torque rise and reliable power with low emissions. It provides excellent fuel economy and system durability.

Direct Injection Fuel System. Individual unit fuel injectors deliver efficient and accurate fuel metering and reduced emissions. The water separator service indicator ensures the operator is alerted when service is necessary.

Enhanced Roothing Speed. Maximum roading speed has been increased to 40 kph (25 mph) for faster travel between jobsites.

Air Cleaner. A dry-type perimeter seal air cleaner with automatic, integrated dust ejection system provides more efficient pre-separation. The two-stage air filter incorporates both air cleaner and precleaner functions into a single unit mounted under the hood.

New Cat Rear Axles. New heavy-duty rear axles are designed specifically for demanding backhoe loader applications. Features include outboard planetary gear sets for serviceability and brake design improvements for longer life.

Torque Converter. The 430E features a new larger torque converter to match its higher horsepower. This delivers higher rimpull which is especially important in truck loading and stockpile work.

Smoother Shifts. New modulated transmission control valves provide smoother speed and directional shifts on all transmissions.

Standard Transmission. The Caterpillar power shuttle transmission provides four speeds forward and reverse. Full synchromesh gears and hydraulically shifted forward and reverse shuttle clutches allow direction and travel speed to be changed on-the-go. A neutral start provision prevents starting while the shuttle is engaged.

Auto-Shift Transmission. The optional automatic transmission matches gears with grade and load conditions. Manual mode gives full gear selection for operation as a power shift transmission. Top gear is selected with the twist grip control on the steering column.

Transmission Kick-Down Switch/Neutralizer. Located on the loader joystick, the kick-down switch on auto-shift machines allows the operator to downshift through the gears to first. When this switch is depressed for more than one second, it serves as the transmission neutralizer to maintain engine and hydraulic speed when truck loading.

Four Wheel Drive (4WD) Option. Heavy-duty front drive axle can be engaged at any time by activating the switch on the front console. The switch can be activated while the machine is stopped or moving, with or without load. 4WD features outboard planetary gear final drives and improves mobility and loader performance in poor traction conditions.

Brake Mode Selector. The brake mode selector switch has three positions: two wheel drive, two wheel drive with all wheel braking and four wheel drive. Center position provides two wheel drive for better tire life while roading and engages the front axle when brakes are applied for improved braking performance.

Ride Control

Optional Caterpillar Ride Control delivers even greater operator comfort.

Ride Control System. The optional Ride Control System incorporates a nitrogen accumulator in the loader lift circuit that smooths the ride in all conditions, including load and carry, highway roading, or simply moving around the jobsite.

Improved Productivity. The Ride Control option improves material retention in the loader bucket for increased productivity and a cleaner jobsite.

Controllability. Ride Control reduces machine loping, providing a smooth and stable ride for increased operator comfort and reduced operator fatigue.

Convenient Operation. The system is easily engaged by a switch on the front console. On Auto-shift machines, the Ride Control switch has three positions, ON, OFF and AUTOMATIC. In the automatic position, the Ride Control engages automatically as the travel speed increases. At low speed, the system disengages for loading, grading or finishing applications.



Backhoe and Loader Features

New extendible stick is designed for better performance, higher force and improved serviceability.

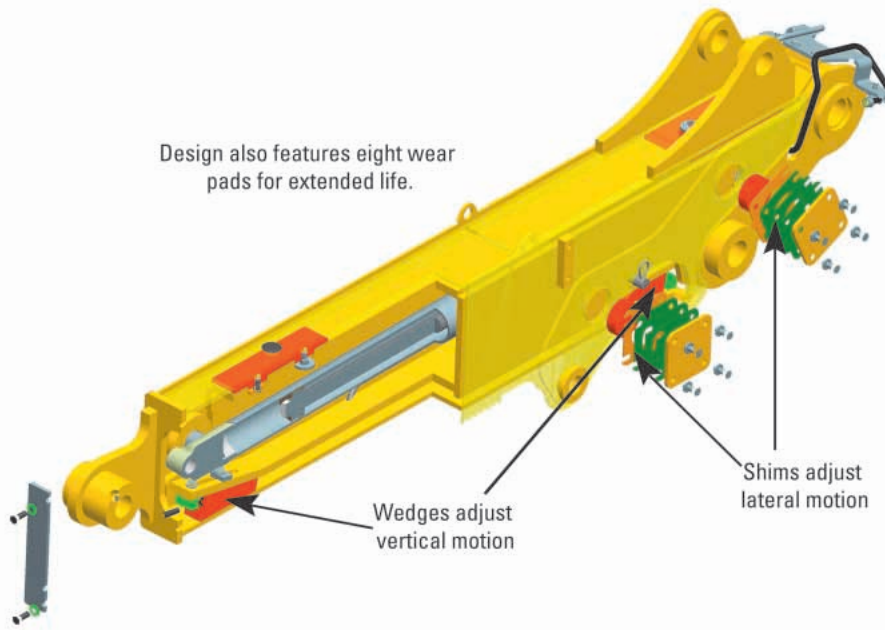

Extendible Stick Design

New Backhoe Design. The completely new E-Series backhoe delivers industry-leading digging forces. Its rugged design provides durability in the toughest applications. Serrated edges on the stick provide improved material clamping for clearing and demolition applications.

New Extendible Stick. The optional extendible stick (E-stick) increases reach and dig depth by approximately 1.2 meters (4 feet). The new design delivers increased life and easy in-field adjustment.

High Rotation Backhoe Linkage. Single pin bucket linkage contributes to best-in-class rotation of 205 degrees for all applications, eliminating the need to change pin positions when moving from loading trucks to vertical wall trenching.

Backhoe Boom. The excavator-style boom features box section fabrication with thicker plates for optimum performance and durability. The curved design provides additional clearance over obstacles while digging a trench or truck loading. The narrow boom enhances the viewing area to the bucket and trench throughout the entire operating range.

Backhoe Swing Casting. New swing casting is designed to handle the high performance of the E-Series backhoe. It features replaceable bushings for durability and serviceability.



Thumb Mounting. Thumb mounting provisions are standard on every Cat Backhoe Loader for added machine versatility. Hydraulic thumbs are available factory-installed.



Single Tilt Loader Linkage. The standard single tilt loader linkage features strong lift and breakout forces for solid performance in backfilling and truck loading applications. The machine is equipped with either a general purpose or multi-purpose pin-on bucket to meet your specific needs.



Integrated Toolcarrier Loader Linkage. The optional integrated toolcarrier (IT) loader linkage provides higher forces, as well as parallel lift, for efficient loading and material handling. Integrated toolcarriers are highly versatile and can use a wide range of Cat Work Tools for a variety of applications. The quick coupler allows quick connection to selected work tools on Cat IT Wheel Loaders and Telehandlers. Mechanical work tools can be changed in less than 30 seconds from the comfort of the operator station.



Quick Disconnects. Flat face hydraulic hose quick disconnect fittings with a connect-under-pressure feature improve the connection of hydraulic work tools.

Loader Controls. The 430E IT features a standard single lever, electro-hydraulic loader control for proportional control and fine modulation of the hydraulic work tools. A thumb roller operates auxiliary hydraulic functions such as the multi purpose bucket.

Loader Return-to-Dig. The return-to-dig system reduces loading cycle times by bringing the loader bucket back to the dig position with an easy pull of the lever. By the time the loader bucket is at ground level, the bucket is angled correctly for the next load or cut.

Work Tools

Choose from a wide variety of tools designed specifically for the backhoe and integrated toolcarrier loader.



Work Tools. Caterpillar Work Tools for backhoe loaders extend the versatility of the machine. Built for performance and durability, these tools deliver high productivity, long service and excellent value.

Backhoe Work Tools.

- Standard Duty Bucket
- Heavy Duty Bucket
- Heavy Duty Rock Bucket
- High Capacity Bucket
- Soil Excavation Bucket
- Coral Bucket
- Ditch Cleaning Bucket
- Cold Planer
- Hydraulic Hammer
- Vibratory Plate Compactor
- Ripper
- Thumb
- Auger

Loader Work Tools.

- General Purpose Bucket
- Multi Purpose Bucket
- Side Dump Bucket
- Light Material Bucket
- Loader Forks
- Material Handling Arm
- Angle Blade
- Broom
- Rake
- Asphalt Cutter
- Bale Spear
- Snow Plow

Bucket Line. Caterpillar's expansive bucket line includes rock and coral buckets. The side profile has a scalloped edge, similar to an excavator bucket, for exceptional fill factor characteristics and secure clamping ability.

Standard Duty Bucket. Used in easy-to-penetrate, low-impact, moderately abrasive materials.

Heavy Duty Bucket. Used for a wide variety of soil conditions such as semi-rocky soil and hard bank material.

High Capacity Bucket. Same durable construction as the heavy duty bucket for tough materials with longer tip radius for increased bucket capacity. Increased draft angle on the tooth adapter provides greater performance.

Heavy Duty Rock Bucket. Specifically designed to address harsh, rocky conditions and capable of digging in granite, caliche and rocky soil.

Coral Bucket. Features highest breakout and short tip radius for breaking up coral.

Soil Excavation Bucket. This high capacity, heavy duty bucket optimizes digging performance over a wide spectrum of ground conditions. With an increased tooth adapter draft angle and new tooth tips, productivity is not only increased, but tooth tips last longer in rocky conditions.

Tips. A variety of bucket tips are available from your Cat dealer for optimum performance in any application.



DRS 230 (Diagonal Retention System). DRS 230 with wide adapters provides maximum strength and improved wear characteristics. Heavy-duty bucket teeth are attached with diagonal pins rather than horizontal pins for easy exchange. The adapters are stronger as a result of this improved diagonal pinning and additional wear material on the bucket teeth increases durability.

Lift Eye. An integral lifting eye is a standard feature of the bucket linkage.



Soil Excavation Bucket with Coupler

Backhoe Quick Couplers. Quick couplers allow for quick attachment of buckets and other work tools. The E-Series high rotation pin grabber design allows buckets to be changed without removing the bucket pins. Other manufacturers' buckets can be coupled with a pin puller coupler, one for Case and E-Series buckets or one for John Deere and E-Series buckets.



Loader Quick Coupler. The hydraulic quick coupler, standard on every IT machine, allows for quick and easy attachment of buckets and other work tools.



Thumb. Available for both the standard and the extendible stick, thumbs increase the versatility of the backhoe with the ability to grip, grab and sort virtually any material.

AccuGrade® Reference Systems for Backhoe Loaders

Advanced technology simplifies excavation, improves accuracy, increases efficiency and lowers production costs.



In-Cab Display. The AccuGrade monitor allows the operator to enter slope and dig depth parameters. The in-cab display with easy to read grade indicator and elevation display delivers all system information to the cab for easy viewing by the operator.

Weatherproof Design. All components are ruggedly designed for dependable performance in harsh environments.

Laser Reference System. The AccuGrade Laser Reference System works with laser transmitters to accurately grade or excavate to a site plan without the use of grade stakes. The advanced system includes all components of the basic system with the addition of the following:

- Laser receiver
- Electric mast
- Laser mast mount
- Laser wiring harnesses
- Laser transmitter and tripod (sold separately)

Advantages. Current trenching and excavating processes are labor intensive, dependent on manpower and instruments. Maintaining consistent grade between grade stakes is challenging, even for experienced operators. The AccuGrade® Reference Systems for Backhoe Loaders reduces labor requirements, aids operators in maintaining a consistent slope across the worksite and reduces material cost.

Applications. The AccuGrade system is designed for a wide range of construction trenching applications. Whether excavating around obstacles such as pipes or grading banks and trenches, the AccuGrade system ensures accurate cuts, precise grades and faster cycle times.

Operation. The AccuGrade Site Reference System for Backhoe Loaders enables the operator to select machine work tool and excavate to pre-determined coordinates. The intuitive software and controls allow the operator to set target grades. The in-cab display provides bucket position and grade settings to ensure the operator excavates to those parameters. Additional feedback is provided through LED lights and sound. The system consists of the following components:

- Cylinder position sensors
- Swing position sensor
- In-cab display
- Inclinometer (pitch and roll sensor)
- Wiring harnesses



Additional Features

Features such as Product Link, combined function hydraulics, stackable counterweights, new stabilizer pads and new work lights increase productivity.

New Combined Function Auxiliary Hydraulics Lines. New backhoe auxiliary lines provide one-way or two-way flow for work tools such as hammers, vibratory compactors, augers and thumbs. Standard hydraulic quick disconnects allow fast tool exchange.

Product Link. This established Caterpillar technology uses a Global Positioning System (GPS) to provide machine data to both Cat dealers and end users. Data can be received by either a web based application system or notification by e-mail or pager. Product Link can provide:

- Machine hours
- Location
- Machine events and diagnostics from data link

Stackable Counterweights.

Stackable counterweights allow easy adjustment of weight distribution without having to completely replace an existing counterweight.

New Work Lights. New work lights are adjustable and better aligned for improved lighting of the work area.

Fuel Tank. Large capacity tank located on the frame's left side is lockable and includes a replaceable, bolt-on step.



Tool and Battery Box. Lockable, hinged door provides easy access to battery box with no hand tools required. Permanent punched hole steel tread plate on top provides stable footing in all weather conditions.

Flip Over Stabilizer Pads. Flip over stabilizer pads provide the ability to work in both dirt and street applications. New pads are stronger, feature a positive anti-flip mechanism and provide increased rubber wear life.

Fabricated Grouser Pads. Designed for dirt applications, the new fabricated grouser pads provide superior strength and durability.

Serviceability and Customer Support

Simplified service and maintenance save you time and money.



Tilt-Up Hood. The tilt-up hood provides easy, convenient access to all engine check points from the left side of the machine. Fill caps are color-coded for quick identification.

On-Board Diagnostics. Electronic control module stores fault codes for easy, efficient troubleshooting and maximum machine uptime.

Selection. Make detailed comparisons of the machines you are considering before you buy. Cat dealers can estimate component life, preventative maintenance and the true cost of lost production. You can also customize the machine that is right for you. Go on-line anytime to review the full range of features and options available using the Build and Quote applications on your dealer's website or www.cat.com.

Purchase. Look at the value E-Series backhoe loaders offer. Consider all the flexible financing options your Cat dealer offers as well as day-to-day operating costs.

Operation. Improving operating techniques can boost your profits. Turn to your Cat dealer for the latest training literature and trained staff.

Maintenance. Repair option programs guarantee the cost of repairs up front. Diagnostic programs such as S•O•SSM and Coolant Sampling and Technical Analysis help you avoid unscheduled repairs.

Replacement. Repair, rebuild or replace? Your Cat dealer can help you evaluate the cost involved so you can make the right choice.

Product Support. You will find nearly all parts at our dealer parts counter. Cat dealers utilize a worldwide computer network to find in-stock parts to minimize machine downtime. Additionally, Caterpillar offers a line of genuine remanufactured components which can help lower repair costs.

Easy Financing. Your Cat dealer can provide a financing package to meet your needs.

Engine

Engine Model	3054C DIT	
Gross Power – SAE J1995	75 kW	101 hp
Gross Power – ISO 14396	75 kW	100 hp
Net Power – SAE J1349	72 kW	97 hp
Net Power – ISO 9249	73 kW	98 hp
Net Power – EEC 80/1269	73 kW	98 hp
Bore	105 mm	4.13 in
Stroke	127 mm	5 in
Displacement	4.4 L	268 in ³
Net Torque Rise @ 1,400 rpm	29%	
Net Peak Torque @ 1,400 rpm – SAE J1349	405 N•m	299 lb ft

- The net power ratings apply at 2,200 rpm when tested under the specified conditions for the specified standard.
- Net power advertised is the power available at the flywheel when the engine is equipped with fan, air cleaner, muffler and alternator.
- Based on standard air conditions of 25° C (77° F) and 99 kPa (29.32 in) in dry barometer.
- Used 35° API gravity fuel having an LHV of 42,780 kJ/kg (18,390 BTU/lb) when used at 30° C (89° F) (reference a fuel density of 838.9 g/L [7.001 lb/gal]).
- No derating required up to 2286 m (7,500 ft).
- Net torque rise meets SAE J1349.

Weights

Operating Weight – Nominal	7294 kg	16,066 lb
Operating Weight – Maximum	10 700 kg	23,568 lb
Cab, ROPS/FOPS	260 kg	573 lb
Auto-Shift Transmission	38 kg	84 lb
Ride Control	25 kg	55 lb
Air Conditioning	46 kg	101 lb
Four Wheel Drive	165 kg	364 lb
MP Bucket 1.0 m ³ (1.3 yd ³) w/Fold-Over Fork	884 kg	1,949 lb
MP Bucket 1.0 m ³ (1.3 yd ³) w/o Fold-Over Fork	557 kg	1,228 lb
Loader, IT w/QC	338 kg	745 lb
Extendible Stick (no weights)	294 kg	648 lb
Counterweights (Option 1)	116 kg	255 lb
Counterweights (Option 2)	231 kg	510 lb
Counterweights (Option 3)	488 kg	1,075 lb

- Total gross machine weight not to exceed 10 700 kg (23,568 lb).

Backhoe

Dig Depth – Standard	4698 mm	15 ft 5 in
E-Stick Retracted	4809 mm	15 ft 9 in
E-Stick Extended	5951 mm	19 ft 6 in
Reach from Swing Pivot – Standard	6049 mm	19 ft 10 in
E-Stick Retracted	6154 mm	20 ft 2 in
E-Stick Extended	7247 mm	23 ft 9 in
Bucket Rotation	205°	
Bucket Dig Force – Standard	70.7 kN	15,892 lb
E-Stick Retracted	69.7 kN	15,680 lb
E-Stick Extended	69.7 kN	15,680 lb
Stick Dig Force – Standard	44.2 kN	9,940 lb
E-Stick Retracted	43.3 kN	9,730 lb
E-Stick Extended	32 kN	7,197 lb
Stick Lift @ 2440 mm (8 ft) – Standard	2718 kg	5,992 lb
E-Stick Retracted	2767 kg	6,100 lb
E-Stick Extended	1966 kg	4,334 lb
Loading Height – Standard	3956 mm	13 ft
E-Stick Retracted	3912 mm	12 ft 10 in
E-Stick Extended	4520 mm	14 ft 10 in
Loading Reach – Standard	1774 mm	5 ft 10 in
E-Stick Retracted	1948 mm	6 ft 5 in
E-Stick Extended	2916 mm	9 ft 7 in

Loader

Bucket Capacity – General Purpose	1 m ³	1.31 yd ³
Bucket Width – General Purpose	2406 mm	7 ft 11 in
Dump Height @ Max Angle – Single-tilt	2604 mm	8 ft 7 in
Dump Height @ Max Angle – IT with QC	2539 mm	8 ft 4 in
Dump Reach @ Max Angle – Single-tilt	821 mm	2 ft 8 in
Dump Reach @ Max Angle – IT with QC	799 mm	2 ft 7 in
Dig Depth – Single-tilt	106 mm	4 in
Dig Depth – IT with QC	147 mm	6 in
Lift Capacity @ Full Height – Single-tilt	2937 kg	6,475 lb
Lift Capacity @ Full Height – IT with QC	3162 kg	6,971 lb
Bucket Breakout Force – Single-tilt	46.3 kN	10,401 lb
Bucket Breakout Force – IT with QC	47.5 kN	10,672 lb

Hydraulic System

Circuit Type	Load-sensing, closed center	
Pump Capacity (@ 2,200 rpm)	163 L/min	43 gal/min
System Pressure	24 898 kPa	3,611 psi
Pump Type	Variable-flow, axial piston	
Steering Type	Front wheel	
Power Steering	Hydrostatic	
2WD Cylinder – Bore	65 mm	2.56 in
Stroke	120 mm	4.72 in
Rod Diameter	36 mm	1.42 in
4WD Cylinder – Bore	65 mm	2.56 in
Stroke	120 mm	4.72 in
Rod Diameter	36 mm	1.42 in
Brake System	Inboard, oil-immersed, multiple disc	

Power Train

Power-Shuttle, Forward 1st	5.9 km/h	3.7 mph
Forward 2nd	9.7 km/h	6 mph
Forward 3rd	20 km/h	12.3 mph
Forward 4th	43.2 km/h	26.8 mph
Power-Shuttle, Reverse 1st	5.9 km/h	3.7 mph
Reverse 2nd	9.7 km/h	6 mph
Reverse 3rd	20 km/h	12.3 mph
Reverse 4th	43.2 km/h	26.8 mph
Auto-Shift (opt), Forward 1st	5.8 km/h	3.6 mph
Forward 2nd	9.4 km/h	5.8 mph
Forward 3rd	19.6 km/h	12.2 mph
Forward 4th	27.1 km/h	16.8 mph
Forward 5th	41.3 km/h	25.8 mph
Auto-Shift (opt), Reverse 1st	5.8 km/h	3.6 mph
Reverse 2nd	12.3 km/h	7.6 mph
Reverse 3rd	27.1 km/h	16.8 mph

- Auto-Shift automatically shifts between second gear and highest selected gear.
- Forward/reverse electric power shuttle is controlled by a conveniently placed, hand operated lever that provides instant direction changes between forward and reverse through power hydraulic clutches.
- Torque converter free-wheel clutch allows the converter stator to free-wheel during high speed, low torque conditions such as roading.
- Single-stage, 2.38:1 stall ratio.
- Travel speeds of two wheel drive backhoe loader at full throttle when equipped with 19.5 × 24 rear tires.

Operating Specifications – Backhoe

Turning Circle: outside, front wheels	8.16 m	26 ft 9 in
Turning Circle: outside, Widest Loading Bucket	10.84 m	35 ft 7 in

- ISO 5010.
- 2WD, 4WD (inner wheel not braked).

Service Refills

Cooling System, A/C	15.9 L	4.2 gal
Cooling System, High-Ambient	16.7 L	4.4 gal
Fuel Tank	144 L	38 gal
Engine Oil w/Filter	7.6 L	2 gal
Transmission – Torque Converter, 2WD, Power Shuttle	18.5 L	4.9 gal
Transmission – Torque Converter, 4WD, Power Shuttle	18.5 L	4.9 gal
Transmission – Torque Converter, 4WD, Auto Shift	19 L	5 gal
Rear Axle	16.5 L	4.4 gal
Rear Axle, Planetaries	1.7 L	0.45 gal
Front Axle, 4WD	7.6 L	2 gal
Front Axle, Planetaries	0.8 L	0.2 gal
Hydraulic System	79 L	21 gal
Hydraulic Tank	38 L	10 gal

Standards

Brakes	SAE J/ISO 3450, ISO 3450 1996
Cab – ROPS	SAE J1040 May 1994/ISO 3741 1994
Cab – FOPS	SAE J/ISO 3449 APR98 LEVEL II and ISO 3449:1992 LEVEL II
Cab – Sound	ANSI/SAE J1166 Oct 98 is 82.4 dB (A)
Exterior Sound	SAE J88 JUN86 is 72.3 dB (A)

Axle Ratings

Front Axle, 2WD, Static	22 964 kg	50,582 lb
Dynamic	9186 kg	20,233 lb
Front Axle, 4WD, Static	22 964 kg	50,582 lb
Dynamic	9186 kg	20,233 lb
Rear Axle, Static	22 964 kg	50,582 lb
Dynamic	9186 kg	20,233 lb

- 4WD and 2WD axles are pendulum mounted and permanently sealed and lubricated, requiring no daily maintenance. Also features double-acting steering cylinder with 52° steering angle for increased maneuverability. Oscillation 10° each direction from centerline.

Brakes

Features:

- Brakes meet the following standards: SAE J1473 and ISO 3450 requirements.
- Self-adjusting, completely enclosed and sealed.
- Foot operated brake pedals can be interlocked for roading.
- Parking/secondary brakes are independent of the service brake system. Parking brake is mechanically applied through an adjustable hand lever located on the right console.

Tires

Choices listed as combination of front/rear tires:

- 335/80R 18 XM37/19.5L-R24 XM37
- 12.5/80-18 NHS (10 ply) 1-3 Super Traction/21L-24 (16 ply) R4 ATU
- 335/80R 18 XM37/19.5L-24 (12 ply) R4 ATU
- 335/80R 18 XM37/19.5L-R24 (152A8) IT 510
- 12.5/80-18 NHS (10 ply) 1-3 Super Traction/19.5L-24 (12 ply) R4 ATU
- 12.5/80-18 (10 ply) 1-3 Super Traction/19.5L-24 R4 (12 ply) IT 525

Engine Features

- Three-ring pistons made of lightweight, silicon/aluminum alloy for strength and maximum thermal conductivity.
- Forged chrome/molybdenum-steel crankshaft with crankshaft with either induction hardened or nitrocarburized journals.
- Front and rear crankshaft oil seals are “lip” type Viton and PTFE designs featuring an integral dust lip.
- Heat resistant, silicone-chrome steel intake and STELLITE-faced exhaust valves provide long life.
- Cylinder block is high strength, cast iron alloy of deep skirt, monobloc design for increased strength and long life.
- Cylinder head is high strength, cast iron alloy construction with extra duty wall and deck thickness. Intake and exhaust ports are precision cast to promote optimum gas flow.
- Direct injection fuel system provides accurate fuel delivery; remote mounted electric lift pump improves serviceability.
- Self-priming electric lift pump for improved cold start capability and easy filter changes.
- Dry-type axial seal air cleaner with integral precleaner, automatic dust ejection system, and filter condition indicator.
- Direct electric, 12-volt starting and charging system with 880 CCA Group 31 maintenance free battery.
- Standard glow plug starting aid system for efficient cold weather starting.
- High contact ratio/gear train, peripheral fixed isolation top cover and open deck block design reduce bare engine noise.
- Higher low end torque for better engine/machine performance.

Standard Duty Buckets

With weld-on adapters and pin-on teeth.

Width (mm/in)	Rated Capacity (liters/ft³)	Weight (kg/lb)	No. of Teeth
305/12	78/2.8	97/213	3
457/18	118/4.2	115/253	4
610/24	175/6.2	132/290	5
762/30	233/8.2	147/323	5
914/36	292/10.3	165/363	6

High Capacity Buckets

With weld-on adapters and pin-on teeth. Adapters feature more aggressive digging angle.

Width (mm/in)	Rated Capacity (liters/ft³)	Weight (kg/lb)	No. of Teeth
457/18	180/6.4	146/321	4
610/24	240/8.5	171/376	5
762/30	320/11.3	195/429	5
914/36	380/13.4	214/471	6

Soil Excavation Buckets

With weld-on adapters and pin-on soil digging teeth. Adapters feature more aggressive digging angle.

Width (mm/in)	Rated Capacity (liters/ft³)	Weight (kg/lb)	No. of Teeth
457/118	181/6.4	153/336	4
610/24	241/8.5	179/395	5
762/30	320/11.3	197/434	5
914/36	380/13.4	223/491	6

Heavy Duty Buckets

With weld-on adapters and pin-on teeth.

Width (mm/in)	Rated Capacity (liters/ft³)	Weight (kg/lb)	No. of Teeth
305/12	78/2.8	105/231	3
406/16	105/3.7	127/279	3
457/18	118/4.2	129/284	4
610/24	175/6.2	151/332	5
762/30	233/8.2	167/367	5
914/36	292/10.3	189/416	6

Heavy Duty Rock Buckets

With weld-on adapters and pin-on teeth.

Width (mm/in)	Rated Capacity (liters/ft³)	Weight (kg/lb)	No. of Teeth
305/12	70/2.5	120/265	3
457/18	127/4.5	150/331	4
610/24	198/7.0	175/386	5
762/30	255/9.5	195/430	5
914/36	311/11.5	210/463	6

Counterweights

Minimum Counterweight Recommendations

Standard Stick

Loader Bucket	Power Train	Single-Tilt		IT Loader w/QC	
		kg	lb	kg	lb
GP	2WD	231	510	116	255
GP	4WD	231	510	no counterweight	
MP	2WD	116	255	no counterweight	
MP	4WD	no counterweight		no counterweight	
Forks	2WD/4WD	N/A	N/A	no counterweight	
Material handling arm	2WD/4WD	N/A	N/A	no counterweight	

Extendible Stick

Loader Bucket	Power Train	Single-Tilt		IT Loader w/QC	
		kg	lb	kg	lb
GP	2WD/4WD	488	1,075	488	1,075
MP	2WD	488	1,075	231	510
MP	4WD	231	510	116	255
Forks	2WD	N/A	N/A	116	255
Forks	4WD	N/A	N/A	no counterweight	
Material handling arm	2WD/4WD	N/A	N/A	231	510

Machine Dimensions

Single-Tilt Loader

	General Purpose (1.00 m ³ /1.31 yd ³)	General Purpose (1.07 m ³ /1.40 yd ³)	General Purpose (1.15 m ³ /1.50 yd ³)
(1) Overall transport length	7356 mm/24 ft 2 in	7424 mm/24 ft 4 in	7424 mm/24 ft 4 in
Overall length (loader on ground)	7303 mm/24 ft 0 in	7366 mm/24 ft 2 in	7366 mm/24 ft 2 in
(2) Overall transport height (standard stick)	3866 mm/12 ft 8 in	3866 mm/12 ft 8 in	3866 mm/12 ft 8 in
Overall transport height (extendible stick)	3890 mm/12 ft 9 in	3890 mm/12 ft 9 in	3890 mm/12 ft 9 in
Overall width	2438 mm/8 ft 0 in	2438 mm/8 ft 0 in	2438 mm/8 ft 0 in
(3) Height to top of cab/canopy	2819 mm/9 ft 3 in	2819 mm/9 ft 3 in	2819 mm/9 ft 3 in
(4) Height to top of exhaust stack	2754 mm/9 ft 0 in	2754 mm/9 ft 0 in	2754 mm/9 ft 0 in
Height to loader hinge pin (transport)	365 mm/1 ft 2 in	407 mm/1 ft 4 in	407 mm/1 ft 4 in
Ground clearance (minimum)	320 mm/1 ft 1 in	320 mm/1 ft 1 in	320 mm/1 ft 1 in
(5) Rear axle centerline to front grill	2704 mm/8 ft 10 in	2704 mm/8 ft 10 in	2704 mm/8 ft 10 in
Front wheel tread gauge	1880 mm/6 ft 2 in	1880 mm/6 ft 2 in	1880 mm/6 ft 2 in
Rear wheel tread gauge	1727 mm/5 ft 8 in	1727 mm/5 ft 8 in	1727 mm/5 ft 8 in
(6) Wheelbase 2WD/4WD	2200 mm/7 ft 3 in	2200 mm/7 ft 3 in	2200 mm/7 ft 3 in

Single-Tilt Loader

	Multi Purpose (1.0 m ³ /1.3 yd ³)	Multi Purpose (1.1 m ³ /1.4 yd ³)
(1) Overall transport length	7352 mm/24 ft 1 in	7352 mm/24 ft 1 in
Overall length (loader on ground)	7264 mm/23 ft 10 in	7264 mm/23 ft 10 in
(2) Overall transport height (standard stick)	3866 mm/12 ft 8 in	3866 mm/12 ft 8 in
Overall transport height (extendible stick)	3890 mm/12 ft 9 in	3890 mm/12 ft 9 in
Overall width	2438 mm/8 ft 0 in	2438 mm/8 ft 0 in
(3) Height to top of cab/canopy	2819 mm/9 ft 3 in	2819 mm/9 ft 3 in
(4) Height to top of exhaust stack	2754 mm/9 ft 0 in	2754 mm/9 ft 0 in
Height to loader hinge pin (transport)	417 mm/1 ft 4 in	417 mm/1 ft 4 in
Ground clearance (minimum)	320 mm/1 ft 1 in	320 mm/1 ft 1 in
(5) Rear axle centerline to front grill	2704 mm/8 ft 10 in	2704 mm/8 ft 10 in
Front wheel tread gauge	1880 mm/6 ft 2 in	1880 mm/6 ft 2 in
Rear wheel tread gauge	1727 mm/5 ft 8 in	1727 mm/5 ft 8 in
(6) Wheelbase 2WD/4WD	2200 mm/7 ft 3 in	2200 mm/7 ft 3 in

IT Loader with Quick Coupler

	General Purpose (1.00 m ³ /1.31 yd ³)	General Purpose (1.15 m ³ /1.50 yd ³)	Multi Purpose (1.0 m ³ /1.3 yd ³)	Multi Purpose (1.1 m ³ /1.4 yd ³)
(1) Overall transport length	7447 mm/24 ft 5 in	7471 mm/24 ft 6 in	7409 mm/24 ft 4 in	7409 mm/24 ft 4 in
Overall length (loader on ground)	7412 mm/24 ft 4 in	7455 mm/24 ft 6 in	7366 mm/24 ft 2 in	7366 mm/24 ft 2 in
(2) Overall transport height (standard stick)	3866 mm/12 ft 8 in	3866 mm/12 ft 8 in	3866 mm/12 ft 8 in	3866 mm/12 ft 8 in
Overall transport height (extendible stick)	3890 mm/12 ft 9 in	3890 mm/12 ft 9 in	3890 mm/12 ft 9 in	3890 mm/12 ft 9 in
Overall width	2438 mm/8 ft 0 in	2438 mm/8 ft 0 in	2438 mm/8 ft 0 in	2438 mm/8 ft 0 in
(3) Height to top of cab/canopy	2819 mm/9 ft 3 in	2819 mm/9 ft 3 in	2819 mm/9 ft 3 in	2819 mm/9 ft 3 in
(4) Height to top of exhaust stack	2754 mm/9 ft 0 in	2754 mm/9 ft 0 in	2754 mm/9 ft 0 in	2754 mm/9 ft 0 in
Height to loader hinge pin (transport)	382 mm/1 ft 3 in	359 mm/1 ft 2 in	372 mm/1 ft 3 in	372 mm/1 ft 3 in
Ground clearance (minimum)	320 mm/1 ft 1 in	320 mm/1 ft 1 in	320 mm/1 ft 1 in	320 mm/1 ft 1 in
(5) Rear axle centerline to front grill	2704 mm/8 ft 10 in	2704 mm/8 ft 10 in	2704 mm/8 ft 10 in	2704 mm/8 ft 10 in
Front wheel tread gauge	1880 mm/6 ft 2 in	1880 mm/6 ft 2 in	1880 mm/6 ft 2 in	1880 mm/6 ft 2 in
Rear wheel tread gauge	1727 mm/5 ft 8 in	1727 mm/5 ft 8 in	1727 mm/5 ft 8 in	1727 mm/5 ft 8 in
(6) Wheelbase 2WD/4WD	2200 mm/7 ft 3 in	2200 mm/7 ft 3 in	2200 mm/7 ft 3 in	2200 mm/7 ft 3 in

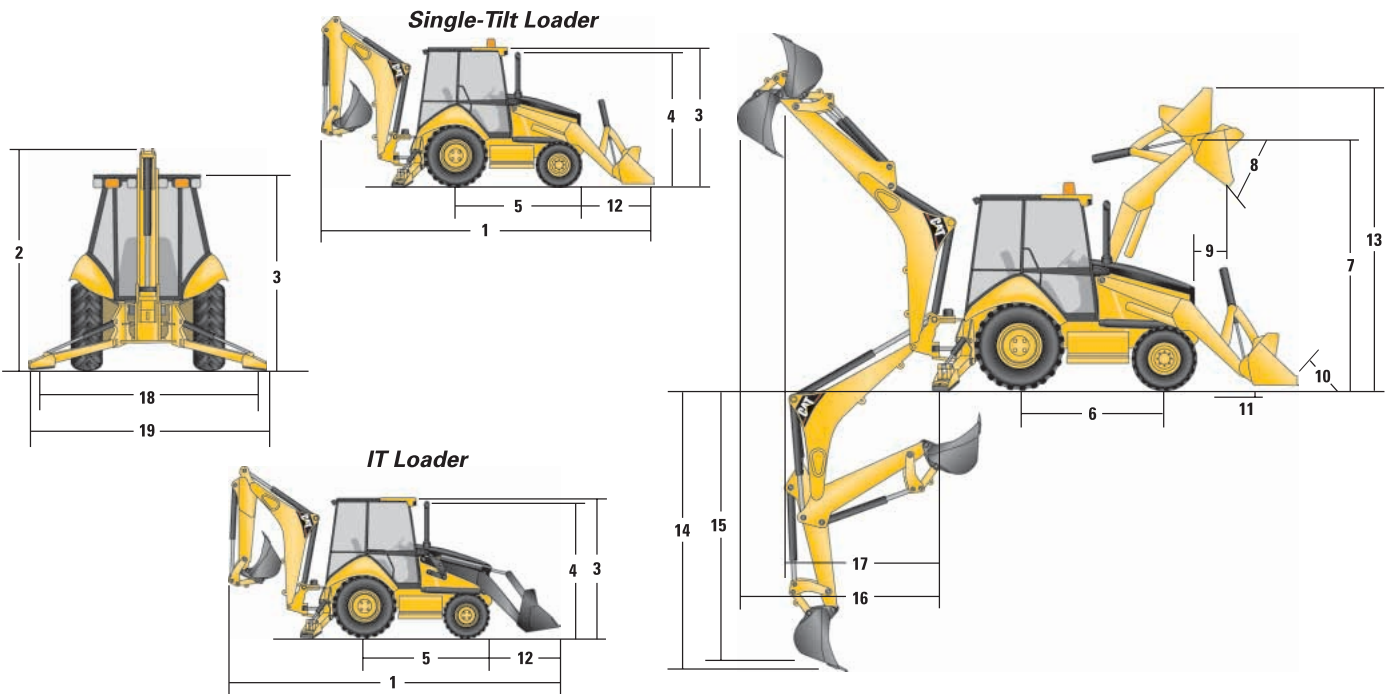

Loader Bucket Dimensions and Performance

	Single-Tilt Loader		
	General Purpose (1.00 m ³ /1.31 yd ³)	General Purpose (1.07 m ³ /1.40 yd ³)	General Purpose (1.15 m ³ /1.50 yd ³)
Capacity (SAE rated)	1.00 m ³ /1.31 yd ³	1.07 m ³ /1.40 yd ³	1.15 m ³ /1.50 yd ³
Width	2406 mm/7 ft 11 in	2262 mm/7 ft 5 in	2406 mm/7 ft 11 in
Lift capacity at maximum height	2937 kg/6,475 lb	2868 kg/6,323 lb	2849 kg/6,281 lb
Breakout force	46.3 kN/10,401 lb	45.1 kN/10,130 lb	44.9 kN/10,091 lb
(7) Maximum hinge pin height	3296 mm/10 ft 10 in	3296 mm/10 ft 10 in	3296 mm/10 ft 10 in
(8) Dump angle at full height	44°	44°	44°
Dump height at maximum angle	2604 mm/8 ft 7 in	2550 mm/8 ft 4 in	2550 mm/8 ft 4 in
(9) Dump reach at maximum angle	821 mm/2 ft 8 in	819 mm/2 ft 8 in	819 mm/2 ft 8 in
(10) Maximum bucket rollback at ground level	39°	40°	40°
(11) Digging depth	106 mm/4 in	146 mm/6 in	146 mm/6 in
Maximum grading angle	108°	108°	108°
Width of dozer cutting edge	N/A	N/A	N/A
(12) Grill to bucket cutting edge, carry position	1484 mm/4 ft 10 in	1551 mm/5 ft 1 in	1551 mm/5 ft 1 in
(13) Maximum operating height	4193 mm/13 ft 9 in	4237 mm/13 ft 11 in	4237 mm/13 ft 11 in
Jaw opening maximum	N/A	N/A	N/A
Bucket jaw clamping force	N/A	N/A	N/A
Weight (does not include teeth or forks)	449 kg/989 lb	459 kg/1,012 lb	479 kg/1,056 lb

	Single-Tilt Loader	
	Multi Purpose (1.0 m ³ /1.3 yd ³)	Multi Purpose (1.1 m ³ /1.4 yd ³)
Capacity (SAE rated)	1.0 m ³ /1.3 yd ³	1.1 m ³ /1.4 yd ³
Width	2262 mm/7 ft 5 in	2406 mm/7 ft 11 in
Lift capacity at maximum height	2739 kg/6,038 lb	2711 kg/5,977 lb
Breakout force	47.1 kN/10,580 lb	46.9 kN/10,546 lb
(7) Maximum hinge pin height	3296 mm/10 ft 10 in	3296 mm/10 ft 10 in
(8) Dump angle at full height	44°	44°
Dump height at maximum angle	2624 mm/8 ft 7 in	2624 mm/8 ft 7 in
(9) Dump reach at maximum angle	761 mm/2 ft 6 in	761 mm/2 ft 6 in
(10) Maximum bucket rollback at ground level	40°	40°
(11) Digging depth	133 mm/5 in	133 mm/5 in
Maximum grading angle	110°	110°
Width of dozer cutting edge	2262 mm/7 ft 5 in	2406 mm/7 ft 11 in
(12) Grill to bucket cutting edge, carry position	1480 mm/4 ft 10 in	1480 mm/4 ft 10 in
(13) Maximum operating height	4244 mm/13 ft 11 in	4244 mm/13 ft 11 in
Jaw opening maximum	790 mm/2 ft 7 in	790 mm/2 ft 7 in
Bucket jaw clamping force	55.7 kN/12,524 lb	55.7 kN/12,524 lb
Weight (does not include teeth or forks)	723 kg/1,594 lb	751 kg/1,656 lb

IT Loader with Quick Coupler

	General Purpose (1.00 m ³ /1.31 yd ³)	General Purpose (1.15 m ³ /1.50 yd ³)	Multi Purpose (1.0 m ³ /1.3 yd ³)	Multi Purpose (1.1 m ³ /1.4 yd ³)
Capacity (SAE rated)	1.00 m ³ /1.31 yd ³	1.15 m ³ /1.50 yd ³	1.0 m ³ /1.3 yd ³	1.1 m ³ /1.4 yd ³
Width	2406 mm/7 ft 11 in	2406 mm/7 ft 11 in	2262 mm/7 ft 5 in	2406 mm/7 ft 11 in
Lift capacity at maximum height	3162 kg/6,971 lb	3131 kg/6,903 lb	2911 kg/6,418 lb	2883 kg/6,356 lb
Breakout force	47.5 kN/10,672 lb	46.8 kN/10,525 lb	45.6 kN/10,256 lb	45.4 kN/10,198 lb
(7) Maximum hinge pin height	3329 mm/10 ft 11 in	3329 mm/10 ft 11 in	3329 mm/10 ft 11 in	3329 mm/10 ft 11 in
(8) Dump angle at full height	45°	45°	45°	45°
Dump height at maximum angle	2539 mm/8 ft 4 in	2509 mm/8 ft 3 in	2574 mm/8 ft 5 in	2574 mm/8 ft 5 in
(9) Dump reach at maximum angle	799 mm/2 ft 7 in	830 mm/2 ft 9 in	778 mm/2 ft 7 in	778 mm/2 ft 7 in
(10) Maximum bucket rollback at ground level	40°	40°	40°	40°
(11) Digging depth	147 mm/6 in	146 mm/6 in	137 mm/5 in	137 mm/5 in
Maximum grading angle	110°	108°	111°	111°
Width of dozer cutting edge	N/A	N/A	2262 mm/7 ft 5 in	2406 mm/7 ft 11 in
(12) Grill to bucket cutting edge, carry position	1575 mm/5 ft 2 in	1598 mm/5 ft 3 in	1536 mm/5 ft 0 in	1536 mm/5 ft 0 in
(13) Maximum operating height	4256 mm/14 ft 0 in	4335 mm/14 ft 3 in	4335 mm/14 ft 3 in	4335 mm/14 ft 3 in
Jaw opening maximum	N/A	N/A	790 mm/2 ft 7 in	790 mm/2 ft 7 in
Bucket jaw clamping force	N/A	N/A	55.7 kN/12,524 lb	55.7 kN/12,524 lb
Weight (does not include teeth or forks)	444 kg/978 lb	468 kg/1,032 lb	703 kg/1,550 lb	731 kg/1,612 lb

Dimensions and performance specifications shown are for machines equipped with 12.5/80-18 SGL front tires, 19.5L-24 IT525 rear tires, ROPS canopy, standard stick with 24 inch standard duty bucket, and 1.00 m³ (1.31 yd³) loader bucket and standard equipment unless otherwise specified.

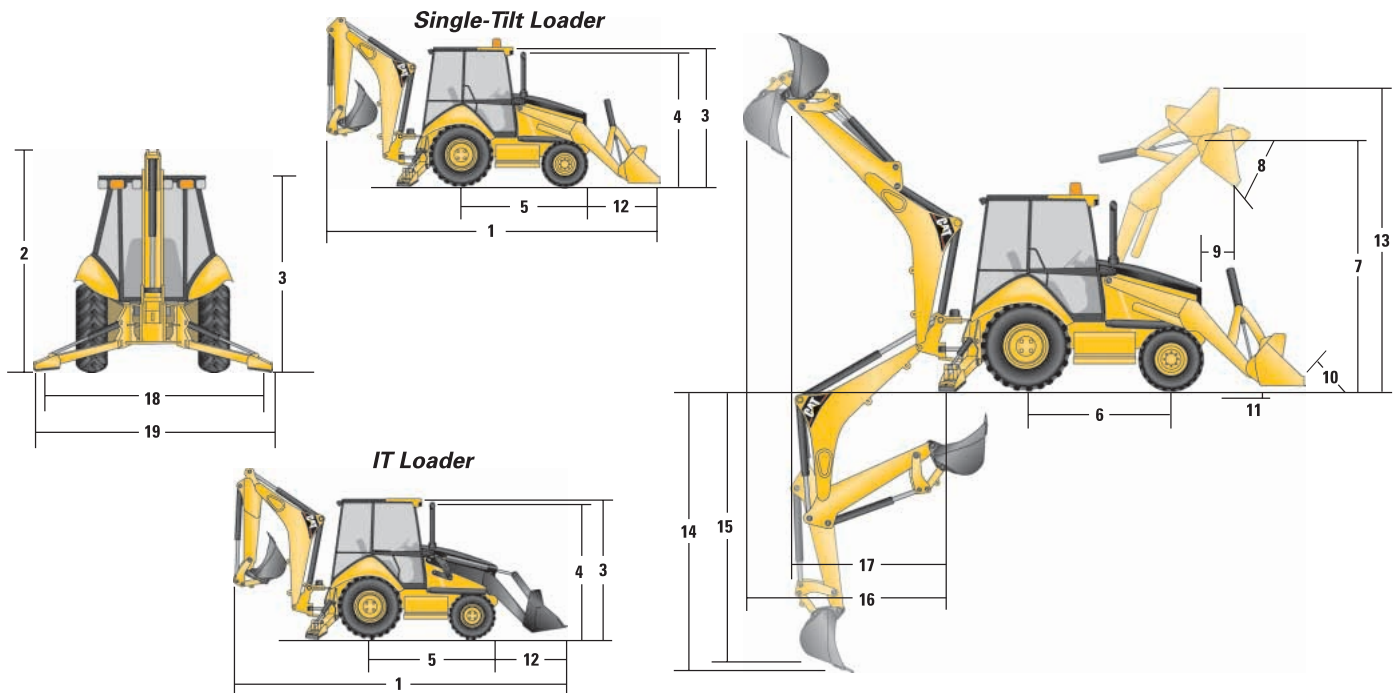

Backhoe Dimensions and Performance

	Standard Stick	Extendible Stick Retracted	Extendible Stick Extended
(14) Digging depth, SAE (max)	4698 mm/15 ft 5 in	4809 mm/15 ft 9 in	5951 mm/19 ft 6 in
(15) Digging depth, 2 ft flat bottom	4672 mm/15 ft 4 in	4783 mm/15 ft 8 in	5925 mm/19 ft 5 in
Reach from rear axle centerline at ground line	7152 mm/23 ft 6 in	7257 mm/23 ft 10 in	8350 mm/27 ft 5 in
(16) Reach from swing pivot at ground line	6049 mm/19 ft 10 in	6154 mm/20 ft 2 in	7247 mm/23 ft 9 in
Maximum operating height	6009 mm/19 ft 9 in	6096 mm/20 ft 0 in	6990 mm/22 ft 11 in
Loading height	3956 mm/13 ft 0 in	3912 mm/12 ft 10 in	4520 mm/14 ft 10 in
(17) Loading reach	1774 mm/5 ft 10 in	1948 mm/6 ft 5 in	2916 mm/9 ft 7 in
Swing arc	180°	180°	180°
Bucket rotation	205°	205°	205°
(18) Stabilizer spread, operating position (center)	3310 mm/10 ft 10 in	3310 mm/10 ft 10 in	3310 mm/10 ft 10 in
(19) Stabilizer spread, operating position (outside)	3770 mm/12 ft 4 in	3770 mm/12 ft 4 in	3770 mm/12 ft 4 in
Stabilizer spread, transport position	2322 mm/7 ft 7 in	2322 mm/7 ft 7 in	2322 mm/7 ft 7 in
Bucket dig force	70.7 kN/15,892 lb	69.7 kN/15,680 lb	69.7 kN/15,680 lb
Stick dig force	44.2 kN/9,940 lb	43.3 kN/9,730 lb	32.0 kN/7,197 lb

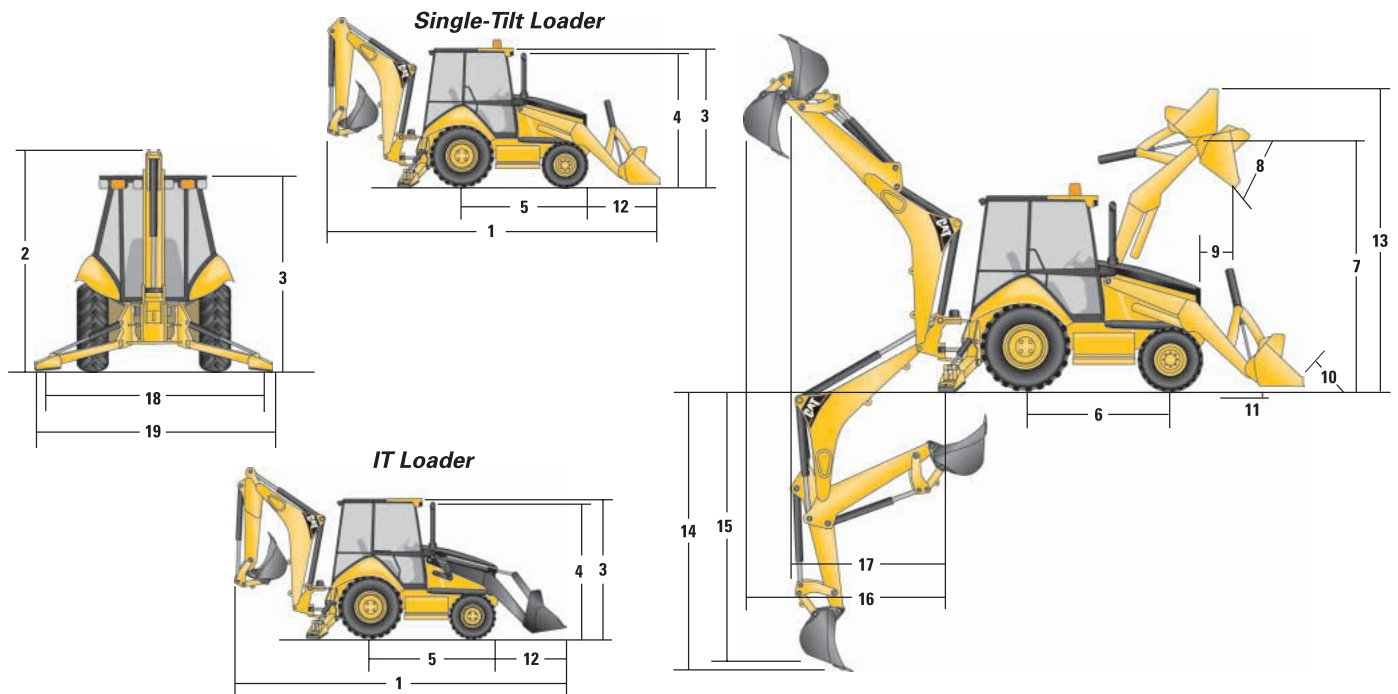

Dimensions with Forks/Material Handling Arm

Cat 430E IT Operating Specifications with Forks

Fork Tine Length:	1070 mm/3 ft 6 in	1220 mm/4 ft 0 in	1370 mm/4 ft 6 in
Operating load (SAE J1197)	2200 kg/4,850 lb*	2127 kg/4,689 lb*	2058 kg/4,536 lb*
SAE load center	535 mm/1 ft 9 in	610 mm/2 ft 0 in	685 mm/2 ft 3 in
Operating load (CEN 474-4)	2507 kg/5,526 lb	2488 kg/5,485 lb	2467 kg/5,438 lb
CEN load center	500 mm/1 ft 8 in	500 mm/1 ft 8 in	500 mm/1 ft 8 in
Overall length (A) (forks on ground)	7857 mm/25 ft 9 in	8007 mm/26 ft 3 in	8157 mm/26 ft 9 in

*Tip limited

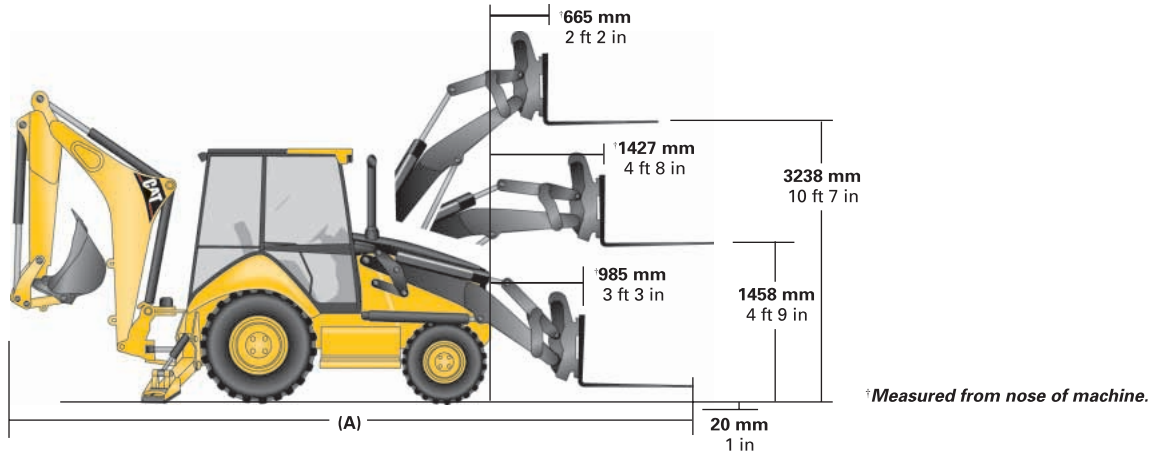

Cat 430E IT Operating Specifications with Material Handling Arm

Material Handling Arm Position:	Retracted	Mid-Position	Extended
Operating load (SAE J1197 & CEN 474-4)	961 kg/2,119 lb**	608 kg/1,340 lb**	445 kg/981 lb**
Overall length, maximum	8948 mm/29 ft 4 in	9948 mm/32 ft 8 in	10 947 mm/35 ft 11 in

Dimensions and performance specifications shown are for machines equipped with 12.5/80-18 SGL front tires, 19.5L-24 IT525 rear tires, ROPS canopy, standard stick with 24 inch standard duty bucket, and 1.00 m³ (1.31 yd³) loader bucket and standard equipment unless otherwise specified.

**Hydraulically limited

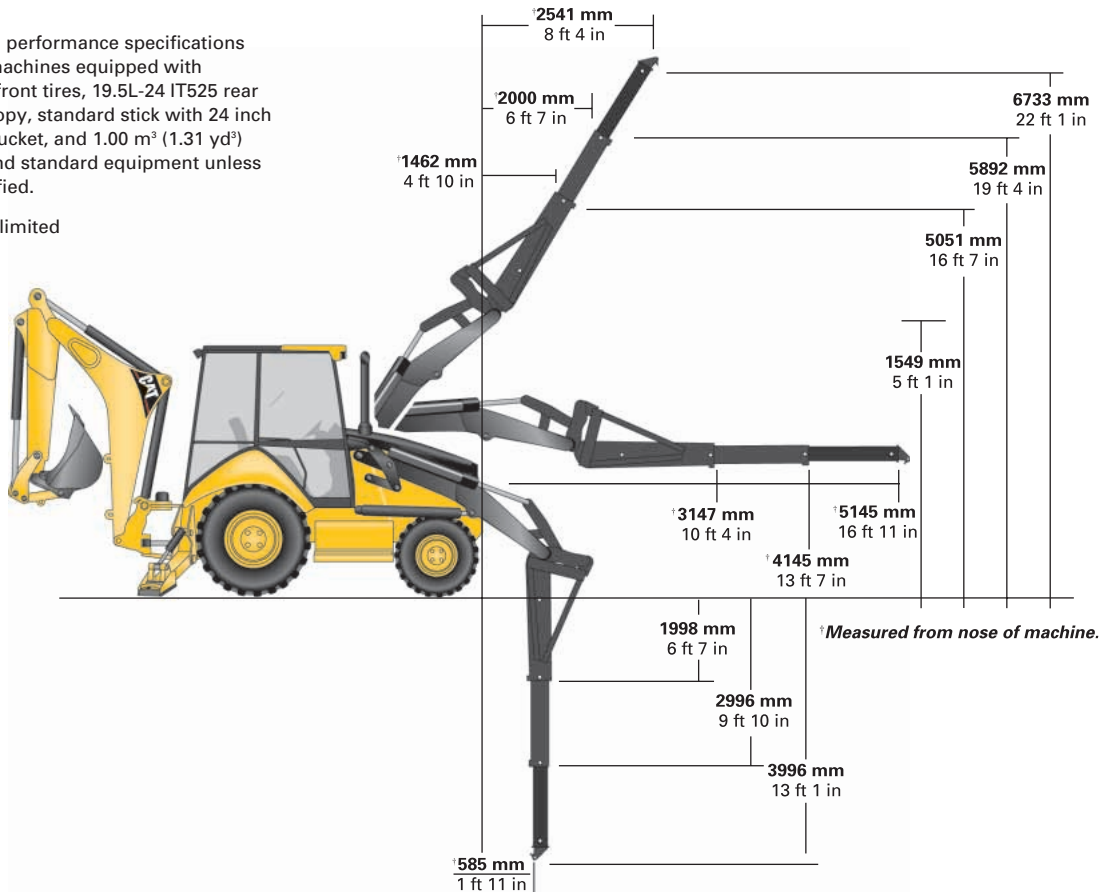

Backhoe Lift Capacity

Cat 430E Standard Stick

KEY

- A — Boom lift kg lb
- B — Stick lift kg lb

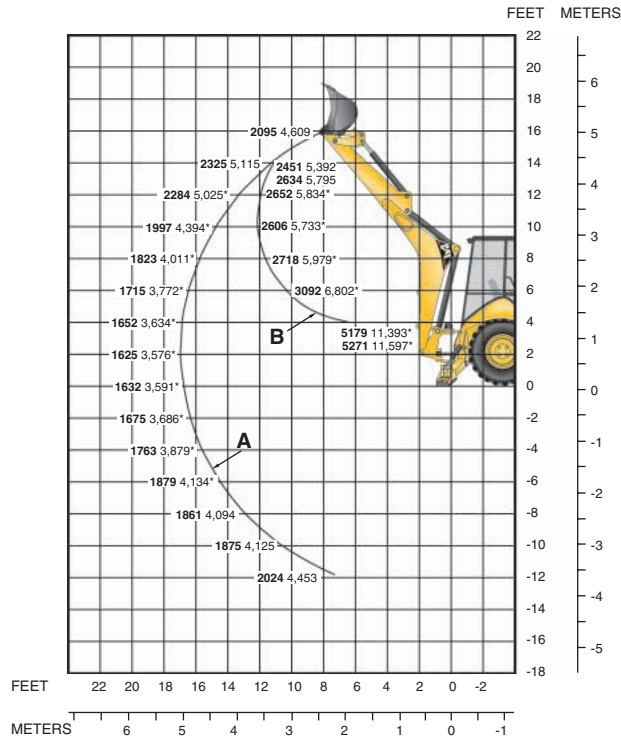

Cat 430E Extendible Stick — Retracted

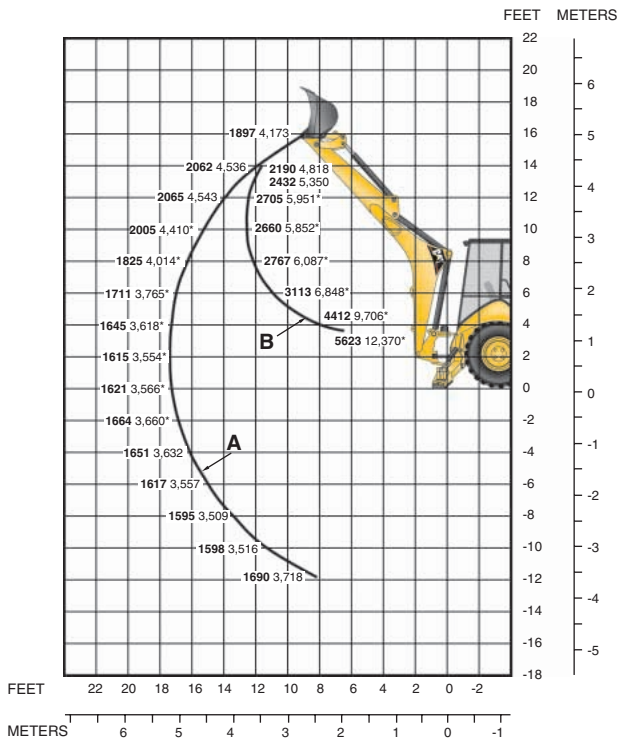

Cat 430E Extendible Stick — Extended

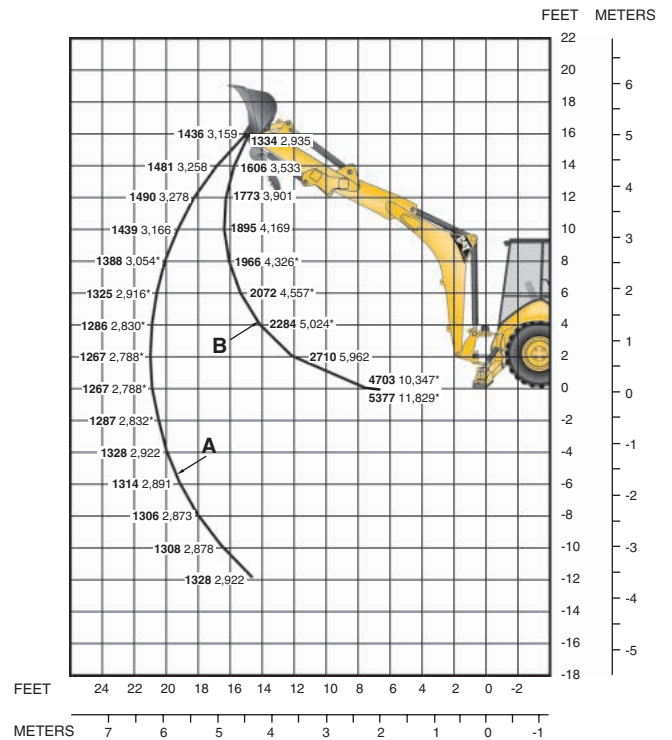

Lift Capacities are over-end values. Machine equipped with 4WD, OROPS, 1.00 m³ (1.31 yd³) general purpose bucket, and 116 kg (255 lb) counterweight. Extendible stick includes 488 kg (1,075 lb) counterweight. *Indicates lift capacity is stability limited.

Standard Equipment

Standard equipment may vary. Consult your Caterpillar dealer for details.

Air cleaner	Joystick controls: pilot operated, excavator-style with pattern changer
Alarm, back-up	Key start/stop system
Backhoe position foot rests	Lights, working (4 front, 4 rear)
Battery, maintenance-free, 880 CCA	Loader, self-leveling, return-to-dig and transmission disconnect switch
Boom transport lock	Lunch box holder
Brace, lift cylinder	Mirror, rear view
Brake, secondary parking	Pattern changer, in cab
Brakes, hydraulically boosted, oil disc, dual pedals, interlocking	Power receptacle, 12V, internal and external
Bucket level indicator	Power steering, hydrostatic
Canopy, ROPS/FOPS	Radio installation kit
Cat cushion swing system	Rubber impact strips on radiator guard
Coat hook	Seat belt, retractable (51 mm/2 in)
Coolant/Antifreeze, extended life	Seat, air suspension, fabric or vinyl cover, with armrest
Counterweight, bumper	Service harness
Dome light (cab only)	Stabilizer controls, pilot operated
Differential lock	Stabilizer shoes, grouser type
Engine, Cat 3054C DIT (Direct Injection Turbocharged)	Starting system, glow plugs
Engine enclosure	Storage compartment, internal
Face seals, O-ring	Stop and tail lights
Fan, suction and guard	Swing transport lock
Fast reversing shuttle, all gears	Tilt steering wheel
Fenders, rear	Tires, see page 19
Filters, spin-on	Toolbox, external, lockable
Fuel, engine oil, transmission oil, water separator, hydraulic fluid	Torque converter
Flashing hazard/signal lights	Throttles, hand and foot
Floor mat	Transmission, four speed, synchromesh
Gauges	Transmission neutralizer switch
Coolant temperature, fuel level, tachometer, hour meter, torque converter oil temperature	Transport tie-downs
Ground level fuel fill	Warning horn, electric
Hydraulic hose, XT™-3 ES	
Hydraulic oil cooler	
Indicators	
Air cleaner service, water separator service, brake on, engine coolant, hydraulic oil level sight gauge, oil pressure	
Instrument panel lights	

Optional Equipment (with approximate change in operating weight)

Optional equipment may vary. Consult your Caterpillar dealer for specifics.

	kg	lb		kg	lb
AccuGrade® Site Reference System for Backhoe Loaders	19	42	Cutting edge, bolt-on, two piece	70	154
AccuGrade Laser Reference System for Backhoe Loaders	48	105	Fenders, 4WD, front	12	26
Attachments, backhoe			Fenders, rear extensions	1	2
Mechanical Quick Coupler			Guards		
D and E-Series buckets	75	165	Stabilizer, rock	31	68
C-Series buckets	75	165	High ambient cooling package	2	4
D, E and Deere buckets	75	165	Hydraulic valves, loader (3rd valve for GP, MP or Quick Coupler)	27	59
D, E and Case buckets	80	176	Hydraulic valves, backhoe		
Hydraulic thumb	139-157	306-345	5th Function	5	11
Attachments, front loader			6th Function	5	11
General purpose buckets			Hydraulic lines		
1.0 m ³ (1.3 yd ³)	462	1,016	Combo, Standard Stick	27	59
1.07 m ³ (1.4 yd ³)	473	1,041	Combo, E-Stick	27	59
1.15 m ³ (1.5 yd ³)	493	1,085	One-way, E-Stick	22	48
Multi purpose bucket			Loader, IT with hydraulic QC and pilot loader control	338	744
1.0 m ³ (1.3 yd ³)	557	1,225	Product Link	4	9
1.0 m ³ (1.3 yd ³) with forks	884	1,945	Ride control	22	48
1.1 m ³ (1.4 yd ³)	742	1,632	Rotating beacon		
1.1 m ³ (1.4 yd ³) with forks	908	1,998	Magnetic mount	5	11
Carriage, fork	218	480	Seat belt, 75 mm (3 in)	0	0
Material handling arm	425	935	Stabilizers, available with guards		
Axle, front			Street	37	81
Four wheel drive with driveshaft guard	155	341	Reversible	38	84
Battery, additional, 880 CCA	25	55	Sticks		
Cab, deluxe with air conditioning	263	579	Extendible	279	614
Cab, standard	225	495	Teeth, loader bucket	45	99
Canopy Plus, ROPS	15	33	Transmission, auto-shift	25	55
Coolant, additional protection, -50° C (-58° F)	0	0	Vandalism protection		
Counterweights			Gauge cover	1	2
255 lb	116	255	Padlocks	1	2
510 lb	231	510	Hood lock	0	0
1,075 lb	488	1,075			

430E/430E IT Backhoe Loader

For more complete information on Cat products, dealer services,
and industry solutions, visit us on the web at www.cat.com

© 2006 Caterpillar
All Rights Reserved
Printed in U.S.A.

Materials and specifications are subject to change without notice.
Featured machines in photos may include additional equipment.
See your Caterpillar dealer for available options.

AEHQ5686-01 (10-06)
Replaces AEHQ5686

CAT, CATERPILLAR, AccuGrade, their respective logos and "Caterpillar Yellow," as well
as corporate and product identity used herein, are trademarks of Caterpillar
and may not be used without permission.

CATERPILLAR[®]