

**MT500D SERIES
SPECIFICATIONS**

Challenger

INTRODUCING THE CHALLENGER MT500D SERIES.

READY. WILLING. INCREDIBLY ABLE.

Challenger





Get Ready For Go Time

You need a machine that knows you mean business. A machine that's built for performance and productivity and styled for comfort and control. A machine that's ready to go — all day, every day and well into the night.

With more power, increased efficiency and unprecedented ergonomic control, the all-new Challenger® MT500D Series is that machine. Designed to give you exactly what you need, it redefines expectations of what a tractor should be — on the field and in the cab.

Right-sized. Right-powered. Seriously evolved.

Your tractor isn't just a tool or a piece of equipment. It's your key to productivity and profitability. The MT500D Series combines e3 clean air technology with the TechStar™ CVT transmission and the Tier 4i-compliant AGCO POWER™ engine to deliver clean power, performance and efficiency.

Continuous innovation, uncompromised power and a multitude of technologically advanced features create a totally new operator experience, setting the MT500D Series apart from any competition and exceeding all expectations.

See our MT500D Series brochure for full Series specifications.

Models	MT555D	MT565D	MT575D	MT585D
Engine Performance				
PTO HP @ 2,100 rated engine rpm (kW)	140 (104)	150 (112)	165 (123)	180 (134)
ISO engine HP @ 2,100 rated engine rpm (kW)	170 (127)	185 (XXX) AutoPower VI 180 (134)	200 (149)	225 (168) AutoPower VI 220 (164)
Maximum ISO engine HP (kW)	185 (138)	185 (138) AutoPower VI 180 (134)	215 (160)	237 (177) AutoPower VI 235 (175)
Engine				
Rated speed (rpm)	2,100			
Maximum torque rise	54%			
Maximum power bulge	15%			
Type	AGCO POWER™ w/ e3 clean air technology			
Model	66 CTA	66 CTA	TechStar - 66 CTA AutoPower VI - 74 CTA	74 CTA
Number of cylinders	6			
Aspiration	Turbocharged and air-to-air aftercooled			
Type of Cooling	Liquid Cooling			
Displacement liters (CID)	6.6 (402)	6.6 (402)	6.6 (402) / 7.4 (452)	7.4 (452)
Transmission				
Type	Techstar™ CVT with Power Management (PM); <i>Continuously Variable Transmission (CVT) available on Deluxe and Premium Editions only</i>			
Field speed range	0.02 - 17 mph Forward and 0.02 - 10 mph Reverse (0.03 - 28 kmh Forward and 0.03 - 16 kmh Reverse)			
Road speed range	0.02 - 25 mph Forward and 0.02 - 24 mph Reverse (0.03 - 40 kmh Forward and 0.03 - 38 kmh Reverse)			
Road speed range - 50 kph (optional)	0.02 - 31 mph Forward and 0.02 - 24 mph Reverse (0.03 - 50 kmh Forward and 0.03 - 38 kmh Reverse)			
Front Axle				
2-wheel drive	N/A			
4-wheel drive differential lock	Full-locking, electrohydraulic standard			
4-wheel drive maximum steering angle	55°			
Quadlink front axle suspension	Standard on Deluxe and Premium, optional on Classic			
Quadlink differential lock	Full-locking, electrohydraulic			
PTO				
Speeds - standard rpm	Classic base - 540/1000, Deluxe and Premium Base - 540/1000/540E			

Models	MT555D	MT565D	MT575D	MT585D
Hydraulics				
System type	Closed Center Load Sensing (CCLS)			
Total flow rate - US standard gallon (L)	29 (110); optional – 39 (150)			
Maximum pressure PSI (bar)	2,900 (200)			
Available flow rate per spool valves gpm (L/min)	24.3 GPM (92 LPM)			
Remotes				
Classic – standard	1-2-3 Mechanical			
Classic – optional	4th mechanical			
Deluxe – standard	1-2 electric fingertips (joystick optional), 3-4 mechanical			
Deluxe – optional	1-2 electric joystick			
Premium – standard	1-2-3-4 electric, all fingertips (joystick optional on 1-2)			
Premium – optional	5th electric valve option on Premium AutoPower VI model only, 1-2 electric joystick			
Three Point Hitch - Rear				
Category 3 With Fixed Ball End Links with Cat 3 Quick Hitch	Standard			
Category 3 With Fixed Ball End Links without Quick Hitch	Optional			
Stabilizers	Rub Block on AutoPower VI, Variable Telescoping on TechStar CVT			
Lift Capacity 24" back of the pin	12,500 for AutoPower VI models, 11,650 for all TechStar CVT models			
Operator Area				
Cab glass area ft ² (m ²)	61 (5.67)			
Noise level dB(A)	70			
Operator Seat – Air Suspension	Standard			
Operator Seat – Deluxe	Optional			
Sears Deluxe Seat	Optional			
Guidance System				
Auto-Steering Ready with Topdock Included and Tractor Management Center (TMC)	Standard on Premium Models, Optional on Deluxe Models			
Digital Instrument Panel with Radar and Slip Control, No TMC Display	Standard on Classic, Optional on Deluxe			
Auto-Steering Ready without Topdock with Tractor Management Center (TMC)	Standard on Deluxe models, Optional on Premium models			
Capacity				
Fuel tank capacity US gallon (L) w/ e3 technology	114 (431 L)			
Diesel Exhaust Fluid tank capacity	11 (40 L)			
Hydraulic Reservoir Capacity Gallon (L)	26.4 (100)			

The Perfect Blend of Power and Efficiency

The Challenger MT500D Series offers the most farmer-friendly approach to meeting EPA standards. We're leading the way in emissions technology by providing best-in-class fluid usage with the most advanced SCR system on the market.

With e3, there are no compromises.

- Optimized horsepower and torque
- Significantly improved fuel economy
- Cooler-running engines
- An easier, more efficient path to meeting EPA standards today and in the future

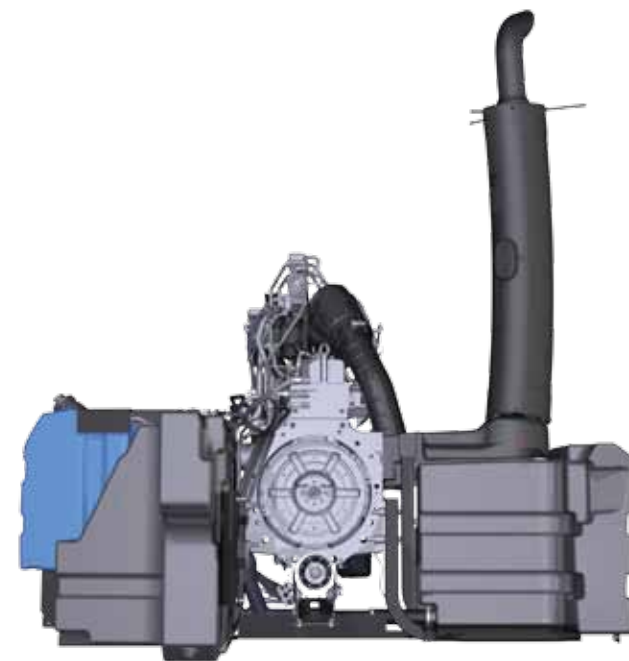

e3 is a post-combustion, after-treatment process that takes place in the exhaust system, never interfering with the performance of the engine itself.



Here's What's New

- Auto-Steering is available direct from the factory, allowing increased productivity at the touch of a button.
- The MT500D Series is AGCOMMAND-ready, allowing you to collect and analyze data that help you make smart, money-saving decisions and optimize fleet up-time.
- The Multi-Function joystick is not just a hydraulic control. Completely customizable with several common features, this industry-unique feature allows you to make this tractor your own, which leads to increased productivity and efficiency.
- The new Multipad Control takes efficiency to heightened levels. With fingertip functionality, the programmable Multipad Control is easy to operate and helps increase overall performance and productivity.



Challenger is a registered trademark of AGCO.

© 2011 AGCO Corporation. AGCO is a registered trademark of AGCO. Challenger is a registered trademark of Caterpillar Inc. and used under license by AGCO. AGCO has a corporate policy of continuous product improvement and development; therefore, specifications are subject to change without any advance notice. All rights reserved. AGCO Corporation, 4205 River Green Parkway, Duluth, GA 30096 | CH11P002DS

