

BP15, BP18 and BA18 Brooms



Skid Steer Loader Work Tools Multi Terrain Loader Work Tools

	Maximum sweeping width
BP15 Pickup Broom	1524 mm (60 in)
BP18 Pickup Broom	1829 mm (72 in)
BA18 Angle Broom	2134 mm (84 in)

Cat® Pickup and Angle Brooms

Collect or windrow dirt and debris from a variety of surfaces.

Caterpillar® Pickup and Angle Brooms are used for cleaning and removing dirt, rock and other debris from streets, parking lots, driveways, sidewalks and factory floors in a variety of construction, industrial and landscaping settings. They are also ideal for paving, specialty trades, recycling, demolition and airport maintenance applications.

Pickup brooms sweep and deposit material into an integrated hopper bucket for easy removal and dumping. They utilize an over-the-brush method which ensures dirt is not forced under previously collected debris. Cat Angle Brooms use a windrowing action to move loose debris ahead and to the side of the surface being swept. They can be oriented straight or angled up to 31 degrees left or right of center. Both units work well on many surfaces, such as asphalt, concrete and turf.

Performance and Versatility

Caterpillar Pickup and Angle Brooms deliver maximum performance and provide smooth, efficient operation when coupled to Cat Skid Steer Loaders and Multi Terrain Loaders. Designed and built to strict Caterpillar standards, they carry with them the proven Caterpillar reputation for performance, versatility and reliability.

Ease of Operation

Caterpillar Pickup and Angle Brooms are designed with the operator in mind. The coupler interface is matched to the Cat Skid Steer Loader and Multi Terrain Loader's mechanical quick coupler system for fast, secure work tool changes. Hydraulic hose routing, hose length and quick disconnects have been optimized to ensure proper protection routing and fit-up. Steps are conveniently located to facilitate operator entry and exit. Operation of Cat Brooms is easy with Caterpillar joystick controls...virtually everything is at your fingertips.



Features:

- **Pickup brooms** are available in two sizes: the 1524 mm (60 in) sweeping width BP15, and the 1829 mm (72 in) sweeping width BP18. Both units offer quick dumping from a dual chain and loader arm bracket system.
- **Angle brooms** are available in one size, the 2134 mm (84 in) maximum sweeping width (straight) BA18.
- **Direct drive system** provides maximum performance and durability. The BP15 Pickup Broom and BA18 Angle Broom use a single variable speed, unidirectional gerotor style hydraulic motor matched to the Caterpillar Skid Steer Loader and Multi Terrain Loader's standard flow auxiliary hydraulic output; the BP18 Pickup Broom uses two in-line motors. The motors are contained in a special support housing and are keyed into a tapered hub on the brush core.
- **Caterpillar XT-3 ES hose, couplings and o-ring face seals** provide superior leak free performance and reliability. All hoses are wrapped with nylon woven Cordura sleeving for added operator protection. Hydraulic quick disconnects enable fast tool changes.
- **Caterpillar bolt-on cutting edges** are standard on pickup broom hopper buckets for long wear life.
- **Optional gutter brush kit** is available for Cat Pickup Brooms to assist in removing material from gutters and pavement edges.
- **Manual or hydraulic angling** is available for Cat Angle Brooms for quick change angling up to 31 degrees right or left of center.
- **Optional brush types** are available for both broom types for various surface requirements.
- **Optional water sprinkler kits** add flexibility to both broom types for dust suppression.

Specifications/Dimensions



Quick Coupler

Caterpillar Skid Steer Loader and Multi Terrain Loader Work Tools incorporate an interface that matches the Caterpillar machine's integrated mechanical quick coupler system. The rugged, opposing wedge design holds the work tool tightly and allows the operator to quickly change from one high performance Cat Work Tool to another.

Serviceability

Cat Pickup and Angle Brooms utilize proven components such as Caterpillar hose, couplings, o-ring face seals and hardware. A full line of replacement parts is readily available from your Cat dealer to help extend work tool system life.

Customer Support

Caterpillar is always ready to assist you in matching the right work tool to your application or machine, adding more Cat Work Tools to your lineup, or obtaining responsible, knowledgeable support.

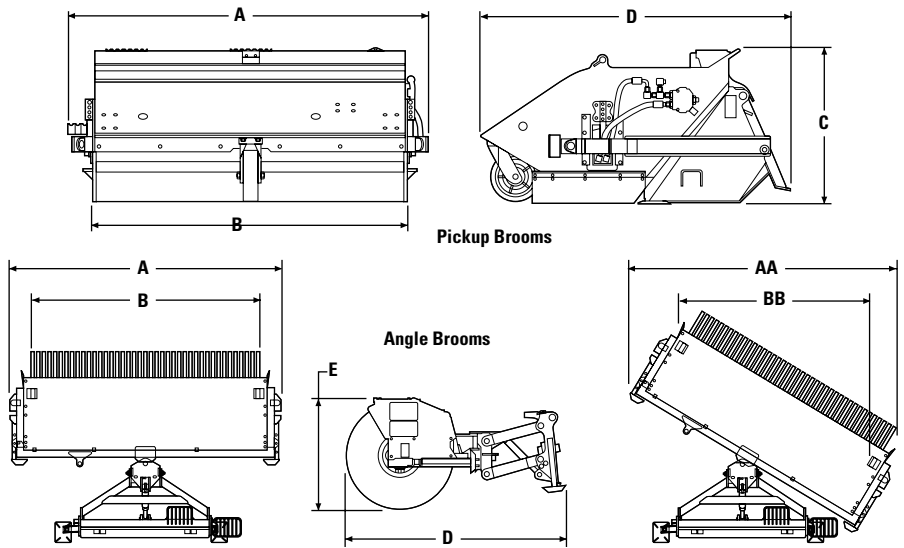

	BP15 Pickup Broom	BP18 Pickup Broom	BA18 Angle Broom
A Overall width	1828 mm (72 in)	2108 mm (83 in)	2388 mm (94 in)
AA Overall width angled*	—	—	2362 mm (93 in)
B Sweeping width	1524 mm (60 in)	1829 mm (72 in)	2134 mm (84 in)
BB Sweeping width angled*	—	—	1702 mm (67 in)
C Height	787 mm (31 in)	787 mm (31 in)	864 mm (34 in)
D Length	1575 mm (62 in)	1575 mm (62 in)	1676 mm (66 in)
Weight**	395 kg (870 lb)	472 kg (1040 lb)	404 mm (890 in)
Drive method	Direct drive	Direct drive	Direct drive
Number of motors	1	2 In-Line	1
Motor size	250 cm ³ (15.3 in ³)	200 cm ³ (12.2 in ³) each	410 cm ³ (24.9 in ³)
Effective displacement	250 cm ³ (15.3 in ³)	400 cm ³ (24.4 in ³)	410 cm ³ (24.9 in ³)
Hydraulic flow range	30-83 l/min (8-22 gpm)	57-95 l/min (15-25 gpm)	42-83 l/min (11-22 gpm)
Hydraulic pressure range	145-227 bar (2100-3300 psi)	145-227 bar (2100-3300 psi)	145-227 bar (2100-3300 psi)
Rated brush speed	150 rpm @ 38 l/min (10 gpm)	190 rpm @ 38 l/min (10 gpm)	159 rpm @ 57 l/min (15 gpm)
Hopper capacity***	0.42 m ³ (0.55 yd ³)	0.45 m ³ (0.59 yd ³)	—
Fasteners	Cat	Cat	Cat
Hydraulic hose	Cat XT-3 ES	Cat XT-3 ES	Cat XT-3 ES
Brush diameter	660 mm (26 in)	660 mm (26 in)	813 mm (32 in)
Brush head retention	Dual chain/ loader arm bracket	Dual chain/ loader arm bracket	—
Brush material (standard)	Replaceable polypropylene/steel wire sections	Replaceable polypropylene/steel wire sections	Replaceable polypropylene/steel wire sections

* 31 degrees right or left.

** With gutter brush.

*** Rated struck capacities shown as per ISO 7546: 1983 and SAE J742 Feb85.

Brooms

Skid Steer Loader Work Tools

Multi Terrain Loader Work Tools

Compatibility

Following are the recommended and approved Cat Skid Steer Loader and Multi Terrain Loader/Broom combinations for maximum system performance.

Work Tool	Skid Steer Loader Models						Skid Steer Loader Models				Multi Terrain Loader Models			
	216	226	228	236	246	248	232	242	252	262	247	257	267	277
BA18 Angle Broom	●	●	●	●	●	●	●	●	●	●	●	●	●	●
BP15 Pickup Broom	● †	●	●	●	●	●	●	●	●	●	●	●	▼	▼
BP18 Pickup Broom	!	!	!	●	●	●	●	●	●	●	●	●	●	●

● Provides optimum system performance

▼ Not recommended

! Not approved – Do not use

† **Lift RESTRICTION** – Do not raise liftarm – work tool hinge pin higher than 1 m (3 ft) above ground. Tipping can result.

www.CAT.com

© 1999, 2002 Caterpillar
Printed in U.S.A.

AEHQ5354-01 (5-02)

Materials and specifications are subject to change without notice.
Featured machines in photos may include additional equipment.
See your Caterpillar dealer for available options.

