

Technical Data

Specifications & Capacities

HTC
8640
SL

Telescopic Boom Truck Crane
40 ton (36.29 metric ton)

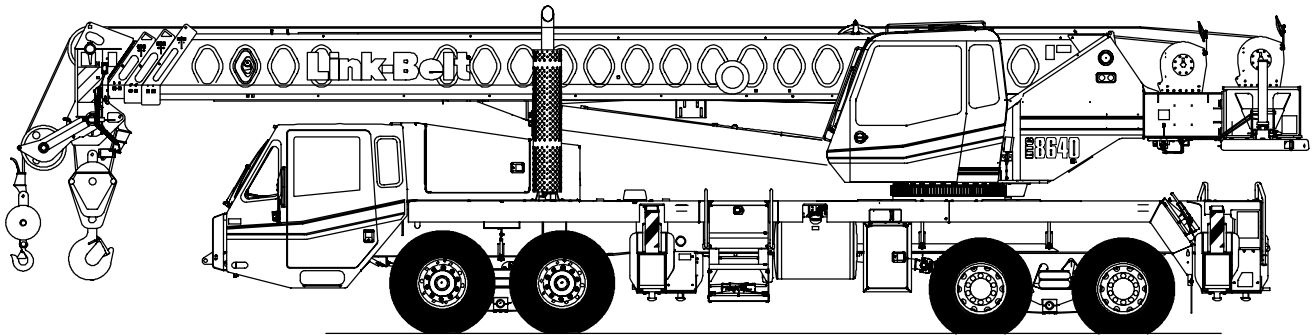

CAUTION: This material is supplied for reference use only. Operator must refer to in-cab Crane Rating Manual and Operator's Manual to determine allowable crane lifting capacities and assembly and operating procedures.

Table Of Contents

Boom, Attachments, and Upper Structure	1
Boom	1
Boom Head	1
Boom Elevation	1
Auxiliary Lifting Sheave – Optional	1
Hook Blocks and Balls – Optional	1
Fly – Optional	1
Upper Operator’s Cab and Controls	1
Swing	2
Electrical	2
Load Hoist System	3
Load Hoist Performance	3
2M Main and Optional Auxiliary Winches	3
Hydraulic System	3
Counterweight	3
Carrier	4
General	4
Outriggers	4
Steering and Axles	4
Suspension	4
Tires and Wheels	4
Brakes	4
Electrical	4
Engine	4
Transmission	4
Carrier Speeds and Gradeability	5
Fuel Tank	5
Hydraulic System	5
Pump Drive	5
Lower Cab and Controls	6
Additional Equipment	6
Axle Loads	7
Axle Loads with 2–Axle Boom Dolly	8
General Dimensions	9
Working Range Diagram	10
Boom Extend Modes	11
Main Boom Lift Capacity Charts – Standard	12
4,300 lb Counterweight – Fully Extended Outriggers – 360° Rotation	12
4,300 lb Counterweight – On Tires – Stationary – Boom Centered Over Rear	13
4,300 lb Counterweight – On Tires – Pick & Carry (1 mph) – Boom Centered Over Rear	13
Main Boom Lift Capacity Charts – Optional	14
7,900 lb Counterweight – Fully Extended Outriggers – 360° Rotation	14
7,900 lb Counterweight – On Tires – Stationary – Boom Centered Over Rear	15
7,900 lb Counterweight – On Tires – Pick & Carry (1 mph) – Boom Centered Over Rear	15

Fly Attachment Lift Capacity Charts – Optional	16
4,300 lb Counterweight – Fully Extended Outriggers – 360° Rotation	16
110 ft Main Boom Length – 2° Fly Offset	16
110 ft Main Boom Length – 20° Fly Offset	16
110 ft Main Boom Length – 40° Fly Offset	16
7,900 lb Counterweight – Fully Extended Outriggers – 360° Rotation	17
110 ft Main Boom Length – 2° Fly Offset	17
110 ft Main Boom Length – 20° Fly Offset	17
110 ft Main Boom Length – 40° Fly Offset	17
Main Boom Lift Capacity Charts – Optional (Metric)	18
1 950kg Counterweight – Fully Extended Outriggers – 360° Rotation	18
1 950kg Counterweight – On Tires – Stationary – Boom Centered Over Rear	19
1 950kg Counterweight – On Tires – Pick & Carry (1.6km/h) – Boom Centered Over Rear	19
3 583kg Counterweight – Fully Extended Outriggers – 360° Rotation	20
3 583kg Counterweight – On Tires – Stationary – Boom Centered Over Rear	21
3 583kg Counterweight – On Tires – Pick & Carry (1.6km/h) – Boom Centered Over Rear	21
Fly Attachment Lift Capacity Charts – Optional (Metric)	22
1 950kg Counterweight – Fully Extended Outriggers – 360° Rotation	22
33.53m Main Boom Length – 2° Fly Offset	22
33.53m Main Boom Length – 20° Fly Offset	22
33.53m Main Boom Length – 40° Fly Offset	22
3 583kg Counterweight – Fully Extended Outriggers – 360° Rotation	23
33.53m Main Boom Length – 2° Fly Offset	23
33.53m Main Boom Length – 20° Fly Offset	23
33.53m Main Boom Length – 40° Fly Offset	23

Boom, Attachments, and Upper Structure

■ Boom

Design – Four section, box type construction of high tensile steel consisting of one base section and three telescoping sections. The vertical side plates have diamond shaped impression for superior strength to weight ratio. The first telescoping section extends independently by means of one double-acting, single stage hydraulic cylinder with integrated holding valves. The second and third telescoping sections extend proportionally by means of one double-acting, single stage cylinder with integrated holding valves and cables.

Boom

- 35.5–110 ft (10.8–33.5m) four-section full power boom
- Two mode boom extension: A-max mode provides superior capacities by extending the first telescope section to 60.3 ft (18.4m). Standard mode synchronizes all the telescoping sections proportionally to 110 ft (33.5m). Controlled from operator's cab.
- Mechanical boom angle indicator
- Maximum tip height for A-max mode is 68.8 ft (21.0m) and standard mode is 117.4 ft (35.8m).

Boom Head

- Four 16.5 in (41.9cm) root diameter nylon sheaves to handle up to eight parts of line
- Easily removable wire rope guards
- Rope dead end lugs on each side of the boom head
- Boom head is designed for quick-reeve of the hook block

Boom Elevation

- One double acting hydraulic cylinder with integral holding valve
- Boom elevation: -3° to 78°

Auxiliary Lifting Sheave – Optional

- Single 16.5 in (41.9m) root diameter nylon sheave
- Easily removable wire rope guards
- Does not affect erection of the fly or use of the main head sheaves

Hook Blocks and Balls – Optional

- 25 ton (22.7mt) 3 sheave quick-reeve hook block with safety latch
- 40 ton (36.3mt) 4 sheave quick-reeve hook block with safety latch
- 8.5 ton (7.7mt) swivel and non-swivel hook balls with safety latch

Fly – Optional

- 28.5 ft (8.7m) one piece lattice fly, stowable, offsettable to 2° , 20° , and 40° . Maximum tip height is 144.8 ft (44.1m).
- 28.5–51 ft (8.7–15.5m) two piece bi-fold lattice fly, stowable, offsettable to 2° , 20° and 40° . Maximum tip height is 166.9 ft (50.9m).

■ Upper Operator's Cab and Controls

Environmental Cab – Fully enclosed, one person cab of galvalneal steel structure with acoustical insulation. Equipped with:

- Tinted and tempered glass windows
- Extra-large fixed front window with windshield wiper and washer
- Swing up roof window with windshield wiper
- Sliding left side door with large fixed window
- Sliding rear and right side windows for ventilation
- Six way adjustable, cushioned seat with seat belt and storage compartment
- Engine dependent warm-water heater with air ducts for front windshield defroster and cab floor
- Defroster fan for the front window
- Bubble level
- Circulating fan
- Adjustable sun visor
- Dome light
- Cup holder
- Fire extinguisher
- Left side viewing mirror
- Pull-out cabwalk
- Two position travel swing lock

Air Conditioning – Optional – Integral with cab heating system utilizing the same ventilation outlets

Armrest Controls – Two dual axis hydraulic joystick controllers or optional single axis hydraulic controllers for:

- Swing
- Boom hoist
- Main rear winch
- Auxiliary front winch – optional
- Drum rotation indication
- Drum rotation indicator activation switch
- Winch high/low speed and disable switch(es)
- Third wrap selector switch – optional
- Telescopic override switch
- Warning horn button
- Swing park brake switch

Outrigger Controls – Hand held control box with umbilical cord gives the operator the freedom to view operation while setting the outriggers.

Drive and Steer Controls – Optional – Hand held control box with umbilical cord gives the operator the ability to drive and steer the crane at low speed from the operator's cab.

Foot Controls

- Boom telescope
- Swing brake
- Engine throttle
- Carrier service brake – optional

Right Front Console – Controls and indicators for:

- Engine ignition
- Engine throttle lock
- Pump enable
- Function disable
- Front windshield wiper and washer
- Cab floodlights
- Warning horn
- Heating controls
- Two position house lock
- Bubble level
- 12 volt power connection
- Carrier park brake – optional
- Air conditioning – optional
- Boom floodlight – optional
- Console dimmer switch

Cab Instrumentation – Ergonomically positioned, analog instrumentation for crane operation including:

- Check and stop engine indicators
- Engine coolant temperature with warning indicator
- Hydraulic oil temperature with warning indicator
- Low air pressure warning indicator
- Fuel level
- Tachometer

Rated Capacity Limiter – Microguard graphic audio–visual warning system integrated into the dash with anti–two block and function limiter. Operating data available includes:

- Crane configuration
- Boom length and angle
- Boom head height
- Allowed load and % of allowed load
- Boom angle
- Radius of load
- Actual load
- Operator settable alarms (include):
 - Maximum and minimum boom angles
 - Maximum and minimum tip height
 - Maximum boom length
 - Left/right swing positions
 - Operator defined area (imaginary plane)

Internal RCL Light Bar – Optional – Visually informs the operator when crane is approaching maximum load capacity with a series of green, yellow, and red lights.

External RCL Light Bar – Optional – Visually informs the ground crew when crane is approaching maximum load capacity with a series of green, yellow, and red lights.

■ Swing

Motor/Planetary – Bi–directional hydraulic swing motor mounted to a planetary reducer for 360° continuous smooth swing at 2.5 rpm.

Swing Park Brake – 360°, electric over hydraulic, (spring applied/hydraulic released) multi–disc brake mounted on the speed reducer. Operated by a switch from the operator’s cab.

Swing Brake – 360°, foot operated, hydraulic applied disc brake mounted to the speed reducer.

Swing Lock – Two–position swing lock (boom over front or rear) operated from the operator’s cab.

360° Positive Swing Lock – Optional – Meets New York City requirement.

■ Electrical

Swing Alarm – Audio warning device signals when the upper is swinging.

Lights

- Two working lights on front of the cab
- One rotating amber beacon on top of the cab – optional
- One amber strobe beacon on top of the cab – optional
- Boom floodlight – optional

Load Hoist System

Load Hoist Performance

Main (Rear) and Auxiliary (Front) Winches – 5/8 in (16mm) Rope										
Layer	Maximum Line Pull		Normal Line Speed		High Line Speed		Layer		Total	
	lb	kg	ft/min	m/min	ft/min	m/min	ft	m	ft	m
1	15,519	7 039.3	163	49.7	327	99.7	97	29.6	97	29.6
2	14,037	6 367.1	181	55.2	361	110.0	108	32.6	205	62.5
3	12,814	5 812.3	198	60.4	396	120.7	117	36.0	322	98.1
4	11,787	5 346.5	215	65.5	460	131.1	128	39.0	450	137.2
5	10,912	4 949.6	232	70.7	465	141.7	139	42.1	589	179.5
6	10,158	4 607.6	250	76.2	499	152.1	148	45.1	737	224.6

Wire Rope Application		Diameter		Type	Maximum Permissible Load	
		in	mm		lb	kg
Main (Rear) Winch	Standard	5/8	16	6x19 IWRC – right regular lay (Type DB)	11,770	5 338.8
	Optional	5/8	16	18x19 rotation resistant – right regular lay (Type RB)	9,080	4 118.6
Auxiliary (Front) Winch	Standard	5/8	16	6x19 IWRC – right regular lay (Type DB)	11,770	5 338.8
	Optional	5/8	16	18x19 rotation resistant – right regular lay (Type RB)	9,080	4 118.6

2M Main and Optional Auxiliary Winches

- Axial piston, full and half displacement (2-speed) motors driven through planetary reduction unit for positive control under all load conditions.
- Grooved lagging
- Power up/down mode of operation
- Hoist drum cable follower – optional
- Drum rotation indicator
- Drum diameter: 10.63 in (27.0cm)
- Rope length:
 - Main: 550 ft (167.6m)
 - Auxiliary: 450 ft (137.2m) or 550 ft (167.6m)
- Terminator style socket and wedge

Third wrap indicator – optional – Visually and audibly warns the operator when the wire rope is on the first/bottom layer and when the wire rope is down to the last three wraps.

Hydraulic System

Counterbalance Valves – All hoist motors, boom extend cylinders, and boom hoist cylinder are equipped with counterbalance valves to provide load lowering and to prevent accidental load drop if hydraulic power is suddenly reduced.

Hydraulic Oil Cooler – Carrier mounted cooler removes heat from the hydraulic oil. Cooler is integral to the engine radiator/charge air cooler.

Boom Hoist Float Valves (Optional) – For transporting the boom over the rear of the crane with a boom dolly. Allows hydraulic oil within the boom hoist cylinder to flow between piston side and rod side, allowing the boom to float while on the boom dolly.

Swing Brake Release – For transporting the boom over the rear of the crane with a boom dolly. Holds the 360° swing park brake in the released position allowing free rotation of the upper structure.

Counterweight

Standard – 4,300 lb (1 950kg) total counterweight with capacities for the 4,300 lb (1 950kg) counterweight configuration.

Optional – 3,600 lb (1 633kg) in addition to standard counterweight for a total of 7,900 lb (3 583kg). Assembled and disassembled by hydraulic cylinders controlled from both sides of the upper structure.

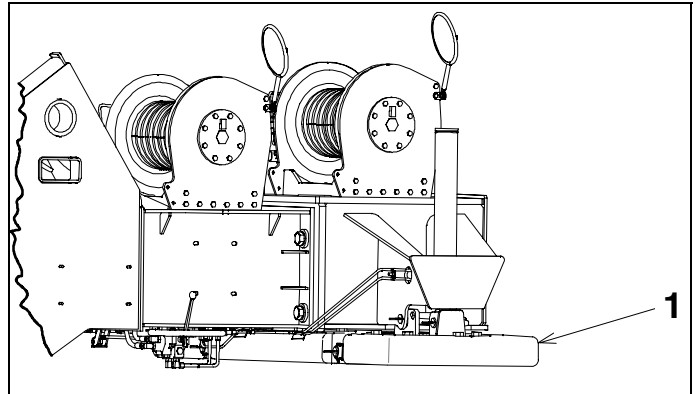

Counterweight Usage Combinations	Standard 4,300 lb (1 950kg)	Optional 7,900 lb (3 583kg)
1		X

Carrier

■ General

- 8 ft 6 in (2.6 m) wide
- 23 ft 10 in (7.26m) wheelbase (centerline of first axle to centerline of fourth axle)
- **Frame** – Box-type, torsion resistant, welded construction made of high tensile steel. Equipped with front and rear towing and tie-down lugs, tow connections, and access ladders.

■ Outriggers

Boxes – Two double box, front and rear welded to the carrier frame

Beams and Jacks – Four single stage beams with Confined Area Lifting Capacities (CALC) provide selectable outrigger extensions of full, intermediate, and retracted positions. Jacks with integral check valve, hydraulically controlled from the operator's cab and on both sides of carrier. A fifth front bumper outrigger with integral check valve is hydraulically controlled from the operator's cab and at the front bumper of carrier.

Pontoons – Four lightweight, stow'n go, 23.5" x 27.25" (59.7 x 69.2cm) hexagonal steel pontoons with a contact area of 485 in² (3 129cm²) can be stored for road travel in either the storage racks on the carrier or under the outrigger boxes.

Main Jack Reaction – 76,000 lb (34 473.0kg) force and 157 psi (1 082.5kPa) ground bearing pressure

■ Steering and Axles

- Sheppard full integral master gear/slave gear steering system provides hydraulic assisted steering with mechanical link between steering wheel and wheels
- **Drive** – 8 x 4 for on/off-highway travel
- **Axle 1 & 2** – Tandem steered, non-driven
- **Axle 3 & 4** – Tandem non-steered, driven with reduction: 5.38 to 1
- **Inter-Axle Differential Lock** – Traction adding device that locks axle 3 with axle 4. Operated by a switch from the carrier cab.

■ Suspension

Front – Raydan Air Link walking beam air suspension

Rear – Raydan Air Link walking beam air suspension

- **Axle Lift System – Optional** – Improves rear tire ground clearance when the crane is up on outriggers. The rear air suspension can be raised or lowered with a switch in the carrier cab. The axle lift system can be controlled with a switch on both sides of the carrier.

■ Tires and Wheels

Front – Four (single) 425/65R22.5 tires on aluminum disc wheels

Rear – Eight (dual) 11R22.5 tires on aluminum outer/steel inner disc wheels

- Spare tires and wheels – optional
- Tire inflation kit – optional

■ Brakes

Service – Full air anti-lock (ABS) brakes on all wheel ends. Dual circuit compressed air system with air dryer.

Parking/Emergency – Spring loaded type, acting on 3rd and 4th axles automatically apply when air pressure drops below 40 psi (275.8kPa) in both circuits.

■ Electrical

Battery – Three batteries provide 12 volt starting and operation

Lights

- Front lighting includes two main headlights, two high beam lights, two parking/directional indicators, and three cab marker lights.
- Side lighting includes three parking/directional indicators per side.
- Rear lighting includes two parking/directional indicators, two parking/brake lights, two reverse lights, three marker lights, and a license plate light.
- Other equipment includes hazard/warning system, cab light, instrument panel light, and signal horn.
- One amber strobe beacon on top of the cab – optional
- Daytime running lights – optional

■ Engine

Specification	Caterpillar C11
Numbers of cylinders	6
Cycle	4
Bore and Stroke: inch (mm)	5.12 x 5.51 (130x140)
Piston Displacement: in ³ (L)	677 (11.1)
Max. Brake Horsepower: hp (kW)	365 (272.2) @ 1,800 rpm 350 (261.0) @ 2,100 rpm
Peak Torque: ft lb (J)	1,350 (1 830) @ 1,200 rpm
Alternator: volts – amps	12 – 145
Crankcase Capacity: qt (L)	22 (20.9)
<ul style="list-style-type: none"> • Cruise control • Three-stage engine compression brake • Thermostatically controlled, hydraulically driven radiator fan • 120 volt engine block heater • Ether injection system – optional 	

■ Transmission

Automated – ZF AS-TRONIC (no clutch pedal) manual transmission with 12 forward gears and 2 reverse gears.

Carrier Speeds and Gradeability

ZF Astronic		Governed Speed		Gradeability (@ Peak Torque Except Creep @ Idle)	
Gear	Ratio	mph	km/h	% Grade	
12th	0.78	60.69	97.65	2.77	
11th	1.00	47.22	75.97	4.10	
10th	1.27	37.27	59.96	5.59	
9th	1.63	28.99	46.64	7.52	
8th	2.10	22.47	36.16	10.00	
7th	2.70	17.49	28.14	13.10	
6th	3.55	13.29	21.39	17.48	
5th	4.57	10.34	16.64	22.68	
4th	5.78	8.16	13.14	28.93	
3rd	7.44	6.35	10.22	37.38	
2nd	9.59	4.92	7.92	48.40	
1st	12.33	3.83	6.16	62.40	
Reverse 1	11.41	4.14	6.66	57.73	
Reverse 2	8.88	5.32	8.56	44.77	
Creep @ idle	2nd	9.59	1.64	2.64	30.15
	1st	12.33	1.27	2.04	38.93
	Reverse 1	11.41	1.38	2.22	36.00
	Reverse 2	8.88	1.77	2.85	27.87

Based on a gross vehicle weight of 72,000 lb (32 659kg)

Fuel Tank

One 75 gal (283.9L) capacity tank

Hydraulic System

All functions are hydraulically powered allowing positive, precise control with independent or simultaneous operation of all functions.

Main Pumps

- Four fixed displacement gear pumps with automatic disconnect for the main and auxiliary winches, swing, boom hoist, control circuit, and telescope for use when crane is in travel mode
- One fixed displacement gear pump for steering and the front bumper outrigger
- Two fixed displacement gear pumps for engine cooling fan and main outriggers. These pumps also provide flow to the winches and boom hoist for “pick & carry” mode. Operated by a switch in the carrier cab.
- Combined pump capacity of 190 gpm (719.2Lpm)

Hydraulic Reservoir – 144 gal (545.1L) capacity equipped with sight level gauge. Diffusers built in for deaeration.

Filtration – One 10 micron, full flow, return line filter. All oil is filtered prior to return to reservoir. Accessible for easy filter replacement.

Pump Drive

All pumps are mechanically driven by the diesel engine. Main and auxiliary winches, swing, boom hoist, control circuit, and telescope pumps are mounted to an automatic pump disconnect on the rear of the transmission to aid in cold weather starting as well as to reduce pump wear while traveling.

■ Lower Cab and Controls

Environmental Cab – Fully enclosed, one person cab of composite structure with acoustical insulation. Equipped with:

- Tinted and tempered glass windows
- Roll down left side window for ventilation
- Sliding rear and right side windows for ventilation
- Windshield wiper and washer
- Six way adjustable and air suspended driver's seat with seat belt
- Two adjustable rear view mirrors
- Engine dependent warm–water heater with air ducts for windshield defroster and cab floor
- Adjustable sun visor
- Dome light
- 12 volt connection
- Fire extinguisher

Air Conditioning – Optional – Integral with cab heating system utilizing the same ventilation outlets

Cab Instrumentation – Ergonomically positioned analog instrumentation for driving including:

- Speedometer with odometer, hourmeter, trip odometer, and clock
- Front and rear air pressure with warning indicator
- Engine coolant temperature with warning indicator
- Engine oil pressure with warning indicator
- Voltage indicator with warning indicator
- Fuel level
- Tachometer

Right Side Console – Controls and indicators for:

- Transmission gear shifting
- Transmission digital readout
- Cruise controls
- Engine compression brake controls

Dash Mounted Controls For:

- Windshield wiper and washer
- Carrier lights
- Carrier/upper throttle control
- Engine cooling fan override
- Cab heater/air conditioning
- Console dimmer switch
- Engine diagnostic switch
- Park brake
- Engine ignition

Dash Mounted Indicator For:

- Check, stop, and service engine
- Turn signal indication
- Park brake
- Cruise activation
- Transmission oil
- High beam headlights
- Anti–lock brake activation

Foot Controls For:

- Carrier service brakes
- Engine throttle

■ Additional Equipment

Standard:

- Aluminum full deck fenders with mud flaps
- Left and right bubble levels
- Air hose connection ports
- Clearance flags

Optional:

- Pneumatic and electrical quick disconnect connectors mounted on the rear for trailer or boom dolly brakes and lights
- Left side aluminum storage box
- Rear mounted pintle hook

Axle Loads

Base crane with full tank of fuel and 4,300 lb (1 950.4kg) counterweight	Gross Vehicle Weight (¹)		Front Axles		Rear Axles	
	lb	kg	lb	kg	lb	kg
	65,712	29 806	30,016	13 615	35,696	16 191
Driver in carrier cab	250	113	328	149	-78	-35
Rear pintle hook	34	15	-13	-6	47	21
Pneumatic and electrical connectors for trailer or boom dolly	11	5	-4	-2	15	7
Carrier aluminum storage box	66	30	20	9	46	21
Air ride lift system – rear axles	52	24	7	3	45	20
Ether injection	7	3	7	3	0	0
Air conditioning – carrier	58	26	83	38	-25	-11
Hoist drum follower – main	75	34	-27	-13	102	47
Auxiliary winch with 450 ft (137.2m) of 5/8" (16mm) type "DB" rope	351	159	-83	-38	434	197
Hoist drum follower – auxiliary	75	34	-16	-8	91	42
Substitute type "DB" rope with "RB" rope – main	77	35	-29	-13	106	48
Substitute type "DB" rope with "RB" rope – auxiliary	63	29	-15	-7	78	35
Substitute 450 ft (137.2m) with 550 ft (167.6m) rope – auxiliary	72	33	-17	-8	89	40
Remove 550 ft (167.6m) of rope from rear (main) winch	-405	-184	154	70	-559	-254
Remove 450 ft (137.2m) of rope from front (auxiliary) winch	-333	-151	80	36	-413	-187
Air conditioner – operator's cab	270	122	4	2	266	120
360° mechanical swing lock	60	27	6	3	54	24
Remote steer	120	54	42	19	78	35
One slab of counterweight on upper	3,582	1 625	-1,375	-624	4,957	2 248
Floodlight to the front of boom base section	10	5	15	7	-5	-2
Fly mounting brackets to boom base section for fly options	99	45	87	39	12	5
28.5 ft (8.7m) offsettable, one-piece lattice fly – stowed	1,238	562	1,312	595	-74	-34
28.5–51 ft (8.7–15.5m) offsettable, two-piece (bi-fold) lattice fly – stowed	1,830	830	1,810	821	20	9
Auxiliary lifting sheave	91	41	165	75	-74	-34
25 ton (22.7mt) 3-sheave hook block at boom head	670	304	1,169	530	-499	-226
40 ton (36.3mt) 4-sheave hook block at boom head	780	354	1,360	617	-580	-263
8.5 ton (7.7mt) hook ball at boom head	360	163	641	291	-281	-127
Hook block/ball storage box	375	170	-143	-65	518	235
25 ton (22.7mt) 3-sheave hook block in storage box	670	304	-256	-116	926	420
40 ton (36.3mt) 4-sheave hook block in storage box	780	354	-298	-135	1,078	489
8.5 ton (7.7mt) hook ball in storage box	360	163	-138	-63	498	226

Counterweight Load Transfer	Front Axles		Rear Axles	
	lb	kg	lb	kg
Transfer one 3,600lb (1 632.9kg) slab of counterweight to carrier deck	4,091	1 856	-4,091	-1 856

Axle	Maximum Load @ 65 mph (105km/h)
Front	45,400 lb (20 593kg) – aluminum disc wheels with 425/65R22.5 tires
Rear	47,250 lb (21 432kg) – aluminum disc wheels with 11R22.5 tires

(¹) Adjust gross vehicle weight and axle loading according to component weight. All weights are ±3%.

Axle Loads with 2–Axle Boom Dolly

Base crane with full tank of fuel and 4,300 lb (1 950.4kg) counterweight	Gross Vehicle Weight ⁽¹⁾		Front Axles		Rear Axles		Dolly Axles	
	lb	kg	lb	kg	lb	kg	lb	kg
	65,712	29 806	30,016	13 615	35,696	16 191	10,733	4 868
Nelson 2–axle boom dolly	6,000	2 722	0	0	0	0	6,000	2 722
Driver in carrier cab	250	113	328	149	–78	–35	0	0
Rear pintle hook	34	15	–13	–6	47	21	0	0
Pneumatic and electrical connectors for trailer or boom dolly	11	5	–4	–2	15	7	0	0
Carrier aluminum storage box	66	30	20	9	46	21	0	0
Air ride lift system – rear axles	52	24	7	3	45	20	0	0
Ether injection	7	3	7	3	0	0	0	0
Air conditioning – carrier	58	26	83	38	–25	–11	0	0
Hoist drum follower – main	75	34	–27	–13	102	47	0	0
Auxiliary winch with 450 ft (137.2m) of 5/8" (16mm) type "DB" rope	351	159	215	98	136	62	0	0
Hoist drum follower – auxiliary	75	34	–16	–8	91	42	0	0
Substitute type "DB" rope with "RB" rope – main	77	35	58	26	19	9	0	0
Substitute type "DB" rope with "RB" rope – auxiliary	63	29	39	18	24	11	0	0
Substitute 450 ft (137.2m) with 550 ft (167.6m) rope – auxiliary	72	33	44	20	28	13	0	0
Remove 550 ft (167.6m) of rope from rear (main) winch	–405	–184	–305	–138	–100	–45	0	0
Remove 450 ft (137.2m) of rope from front (auxiliary) winch	–333	–151	–204	–93	–129	–59	0	0
Air conditioner – operator's cab	270	122	4	2	266	120	0	0
360° mechanical swing lock	60	27	16	7	44	20	0	0
Remote steer	120	54	42	19	78	35	0	0
One slab of counterweight on carrier deck	3,582	1 625	2,716	1 323	866	393	0	0
Floodlight to the front of boom base section	10	5	–1	–0.5	–1	–0.5	12	5
Fly mounting brackets to boom base section for fly options	99	45	12	5	14	6	72	33
28.5 ft (8.7m) offsettable, one–piece lattice fly – stowed	1,238	562	80	36	89	40	1,069	485
28.5–51 ft (8.7–15.5m) offsettable, two–piece (bi–fold) lattice fly – stowed	1,830	830	163	74	182	83	1,484	673
Auxiliary lifting sheave	91	41	–18	–8	–20	–9	130	59
25 ton (22.7mt) 3–sheave hook block at boom head	670	304	–168	–76	–187	–85	1,024	465
40 ton (36.3mt) 4–sheave hook block at boom head	780	354	–138	–63	–154	–70	1,072	486
8.5 ton (7.7mt) hook ball at boom head	360	163	–68	–31	–76	–34	504	229

Counterweight Load Transfer	Front Axles		Rear Axles		Dolly Axles	
	lb	kg	lb	kg	lb	kg
Transfer one 3,600lb (1 632.9kg) slab of counterweight to boom dolly	–2,716	–1 232	–866	–393	3,582	1 625

Axle	Maximum Load @ 65 mph (105km/h)
Front	45,400 lb (20 593kg) – aluminum disc wheels with 425/65R22.5 tires
Rear	47,250 lb (21 432kg) – aluminum disc wheels with 11R22.5 tires

⁽¹⁾ Adjust gross vehicle weight and axle loading according to component weight. All weights are ±3%.

General Dimensions

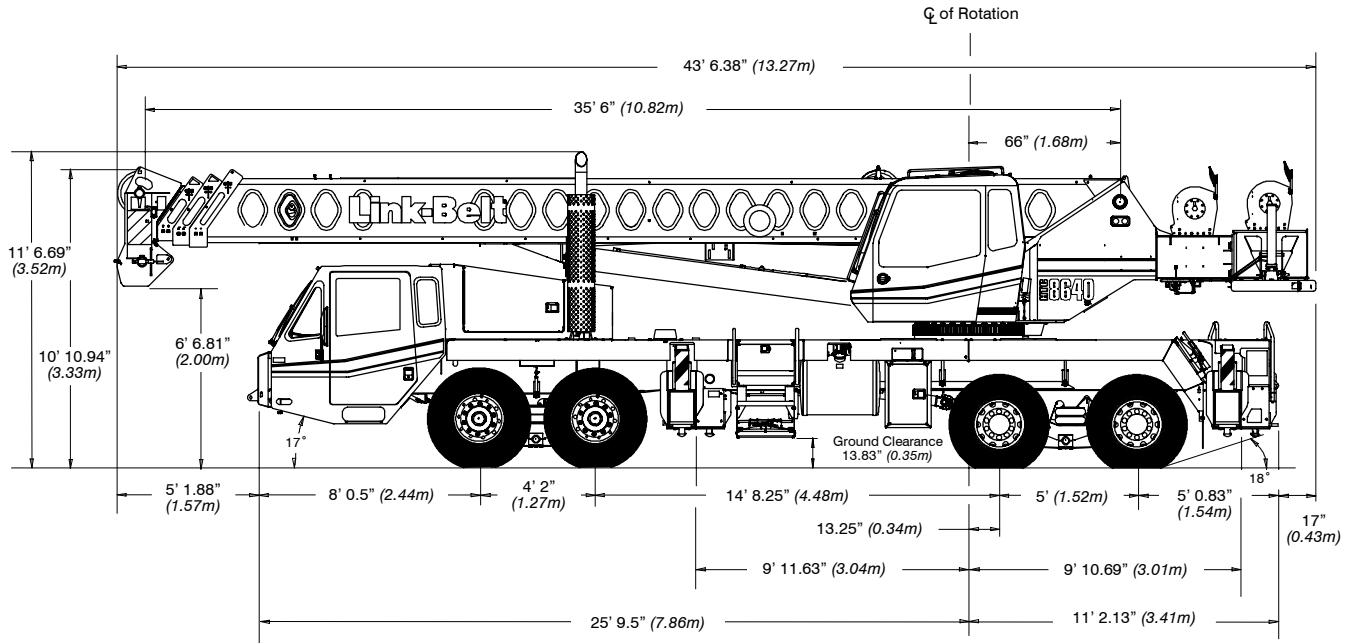

Turning Radius	English	Metric
Wall to wall over carrier	44' 1"	13.4m
Wall to wall over boom	45' 6"	13.9m
Wall to wall over boom attachment	46' 11"	14.3m
Centerline of tire	38' 7"	11.8m

Tail Swing	English	Metric
With counterweight	12' 8.5"	3.9m
Without counterweight	12' 5.25"	3.8m

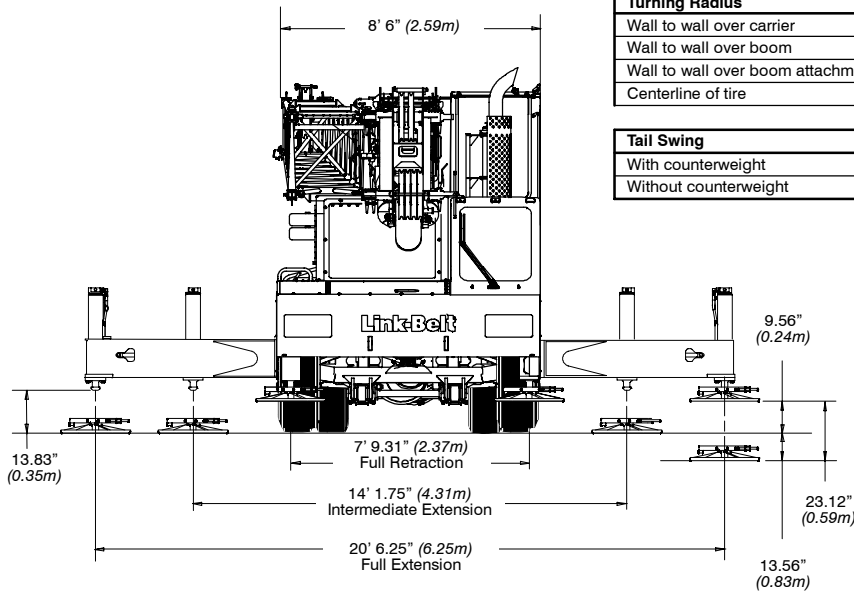

Working Range Diagram

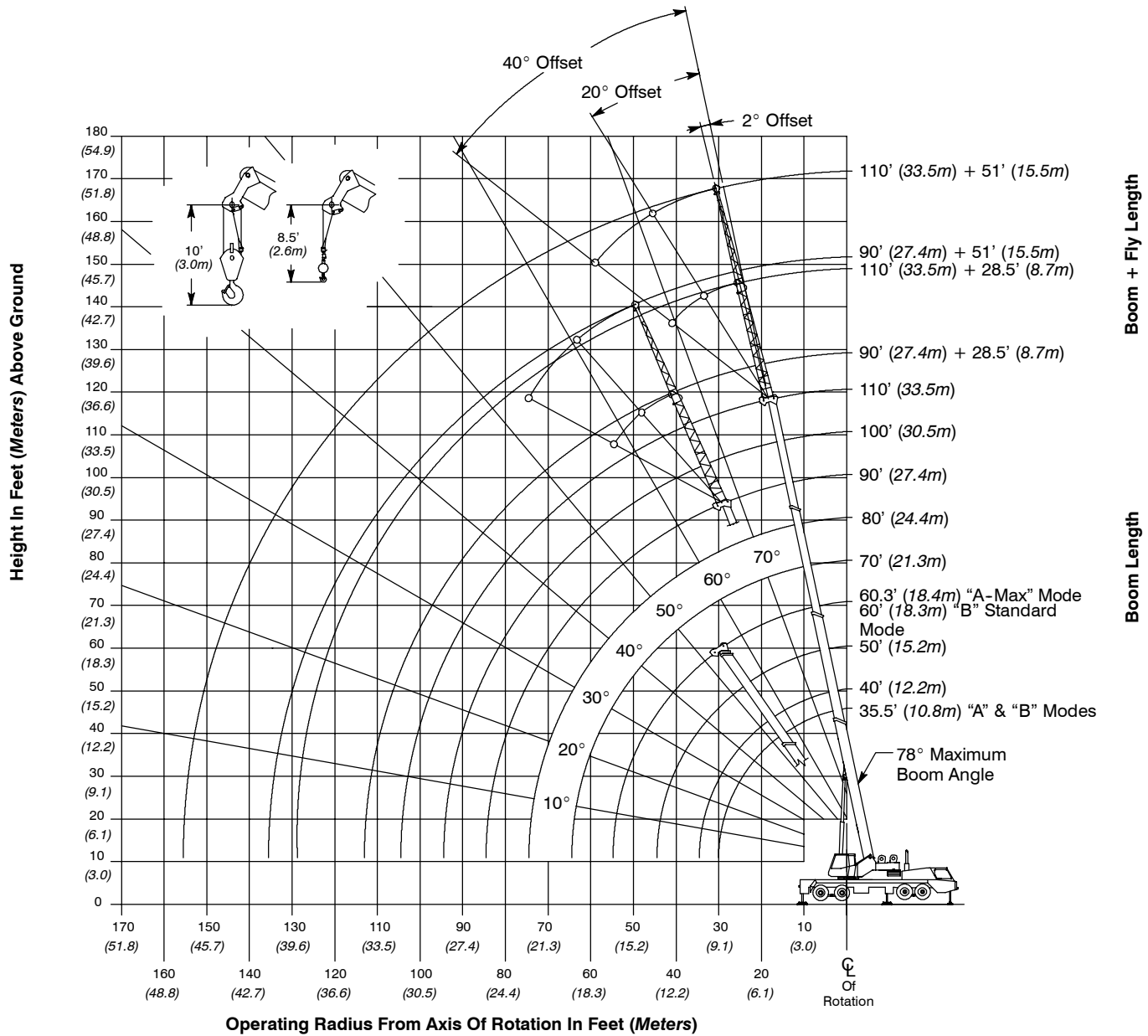

Note: Boom and fly geometry shown are for unloaded condition and crane standing level on firm supporting surface. Boom deflection, subsequent radius, and boom angle change must be accounted for when applying load to hook.



WARNING

Do Not Lower The Boom Below The Minimum Boom Angle For No Load Stability As Shown In The Lift Charts For The Boom Lengths Given. Loss Of Stability Will Occur Causing A Tipping Condition.

Boom Extend Modes

Boom Mode “A” (A–Max)
Only inner mid section telescopes

Boom Length
ft (m)

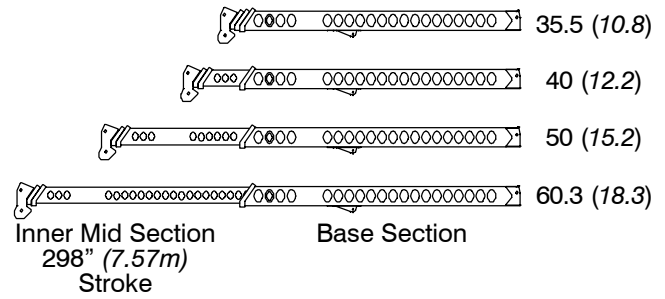

Boom Mode “B” (Standard)
Inner mid, outer mid, and tip sections telescope simultaneously

Boom Length
ft (m)

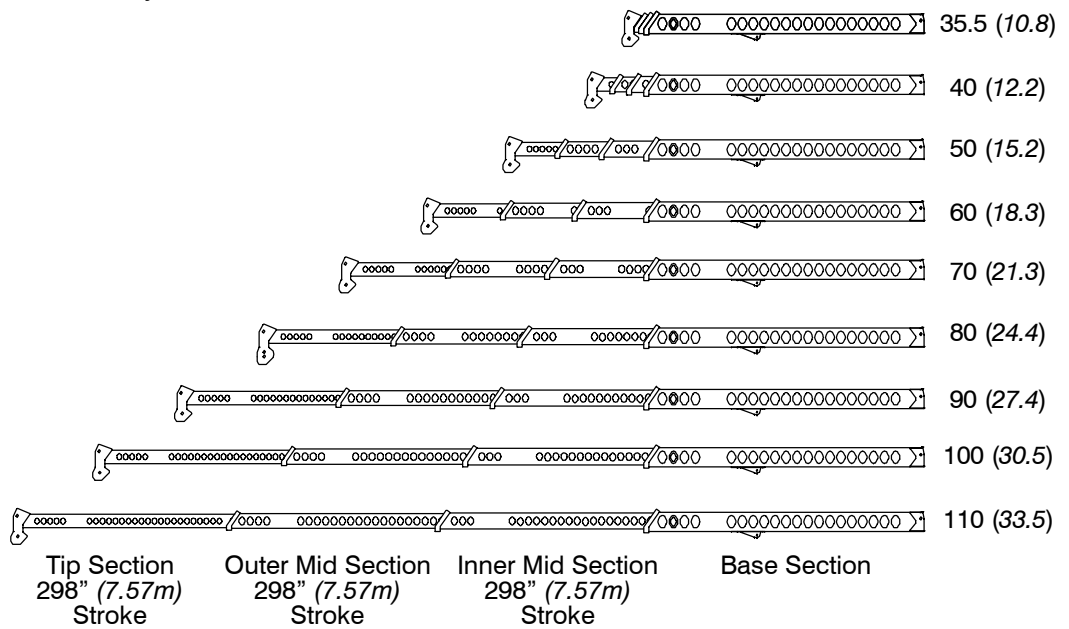

Main Boom Lift Capacity Charts – Standard

4,300 lb Counterweight – Fully Extended Outriggers – 360° Rotation (All Capacities Are Listed In Pounds)											
Radius (ft)	Boom Length (ft)									Radius (ft)	
	35.5	40	50	60	70	80	90	100	110		
10	80,000	80,000	72,800								10
12	76,000	73,200	65,800	50,900	37,900						12
15	65,800	63,600	57,700	47,300	37,900	35,400					15
20	48,900	48,700	47,500	39,300	37,900	34,700	28,900				20
25	32,800	33,400	33,900	34,300	34,500	34,300	28,300	24,000	19,500		25
30		23,000	23,700	24,000	24,200	24,300	24,400	22,600	19,500		30
35			17,500	17,900	18,100	18,200	18,300	18,400	18,400		35
40			13,400	13,800	14,000	14,100	14,200	14,300	14,300		40
45				10,900	11,100	11,200	11,300	11,400	11,500		45
50				8,600	8,900	9,100	9,200	9,200	9,300		50
55					7,200	7,400	7,500	7,500	7,600		55
60					5,700	6,000	6,100	6,200	6,200		60
65						4,800	5,000	5,100	5,100		65
70						3,900	4,000	4,100	4,200		70
75							3,200	3,300	3,400		75
80							2,500	2,600	2,700		80
85								2,000	2,100		85
90								1,500	1,600		90

This information is not for crane operation. Operator must refer to the in-cab information for crane operation. Rated lifting capacities shown on fully extended outriggers do not exceed 85% of the tipping loads and on tires do not exceed 75% of the tipping loads.

4,300 lb Counterweight – On Tires – Stationary – Boom Centered Over Rear
(All Capacities Are Listed In Pounds)

Radius (ft)	Boom Length (ft)						Radius (ft)
	35.5	40	50	60	70	80	
10	43,300						10
12	43,300	37,900					12
15	30,000	30,400	19,600				15
20	18,700	19,100	19,600	13,900			20
25	12,700	13,000	13,600	13,900	10,400		25
30		9,300	9,800	10,100	10,400	10,500	30
35			7,200	7,500	7,800	7,900	35
40			5,300	5,700	5,900	6,000	40
45				4,200	4,500	4,600	45
50				3,100	3,300	3,500	50
55					2,400	2,600	55
60					1,700	1,800	60

4,300 lb Counterweight – On Tires – Pick & Carry (1 mph) – Boom Centered Over Rear
(All Capacities Are Listed In Pounds)

Radius (ft)	Boom Length (ft)						Radius (ft)
	35.5	40	50	60	70	80	
10	36,200						10
12	33,000	33,100					12
15	28,800	29,000	19,600				15
20	18,700	19,100	19,600	13,900			20
25	12,700	13,000	13,600	13,900	10,400		25
30		9,300	9,800	10,100	10,400	10,500	30
35			7,200	7,500	7,800	7,900	35
40			5,300	5,700	5,900	6,000	40
45				4,200	4,500	4,600	45
50				3,100	3,300	3,500	50
55					2,400	2,600	55
60					1,700	1,800	60

This information is not for crane operation. Operator must refer to the in-cab information for crane operation. Rated lifting capacities shown on fully extended outriggers do not exceed 85% of the tipping loads and on tires do not exceed 75% of the tipping loads.

Main Boom Lift Capacity Charts – Optional

7,9000 lb Counterweight – Fully Extended Outriggers – 360° Rotation (All Capacities Are Listed In Pounds)											
Radius (ft)	Boom Length (ft)									Radius (ft)	
	35.5	40	50	60	70	80	90	100	110		
10	80,000	80,000	72,800								10
12	76,000	73,200	65,800	50,900	37,900						12
15	65,800	63,600	57,700	47,300	37,900	35,400					15
20	50,700	50,500	47,500	39,300	37,900	34,700	28,900				20
25	37,200	37,800	37,900	37,900	37,900	34,300	28,300	24,000	19,500		25
30		26,300	27,000	27,300	27,500	27,600	24,900	22,600	19,500		30
35			20,200	20,500	20,700	20,800	20,900	20,100	18,500		35
40			15,600	16,000	16,200	16,300	16,400	16,500	16,500		40
45				12,700	13,000	13,100	13,200	13,200	13,300		45
50				10,200	10,600	10,700	10,800	10,900	10,900		50
55					8,600	8,800	8,900	9,000	9,000		55
60					7,100	7,300	7,400	7,500	7,500		60
65						6,000	6,200	6,200	6,300		65
70						5,000	5,100	5,200	5,300		70
75							4,200	4,300	4,400		75
80							3,400	3,600	3,700		80
85								2,900	3,000		85
90								2,300	2,400		90
95									1,900		95
100									1,400		100

This information is not for crane operation. Operator must refer to the in-cab information for crane operation. Rated lifting capacities shown on fully extended outriggers do not exceed 85% of the tipping loads and on tires do not exceed 75% of the tipping loads.

7,900 lb Counterweight – On Tires – Stationary – Boom Centered Over Rear
(All Capacities Are Listed In Pounds)

Radius (ft)	Boom Length (ft)						Radius (ft)
	35.5	40	50	60	70	80	
10	49,000						10
12	44,800	37,900					12
15	33,500	33,900	22,100				15
20	21,200	21,500	22,100	15,700			20
25	14,500	14,900	15,400	15,700	11,800		25
30		10,800	11,300	11,600	11,800	12,000	30
35			8,500	8,800	9,000	9,200	35
40			6,400	6,800	7,000	7,100	40
45				5,200	5,400	5,600	45
50				4,000	4,200	4,300	50
55					3,200	3,400	55
60					2,400	2,500	60
65						1,900	65
70						1,300	70

7,900 lb Counterweight – On Tires – Pick & Carry (1 mph) – Boom Centered Over Rear
(All Capacities Are Listed In Pounds)

Radius (ft)	Boom Length (ft)						Radius (ft)
	35.5	40	50	60	70	80	
10	36,200						10
12	33,000	33,100					12
15	28,800	29,000	22,100				15
20	21,200	21,500	22,100	15,700			20
25	14,500	14,900	15,400	15,700	11,800		25
30		10,800	11,300	11,600	11,800	12,000	30
35			8,500	8,800	9,000	9,200	35
40			6,400	6,800	7,000	7,100	40
45				5,200	5,400	5,600	45
50				4,000	4,200	4,300	50
55					3,200	3,400	55
60					2,400	2,500	60
65						1,900	65
70						1,300	70

This information is not for crane operation. Operator must refer to the in-cab information for crane operation. Rated lifting capacities shown on fully extended outriggers do not exceed 85% of the tipping loads and on tires do not exceed 75% of the tipping loads.

Fly Attachment Lift Capacity Charts – Optional

4,300 lb Counterweight – Fully Extended Outriggers – 360° Rotation (All Capacities Are Listed In Pounds)								
110 ft Main Boom Length 2° Fly Offset			110 ft Main Boom Length 20° Fly Offset			110 ft Main Boom Length 40° Fly Offset		
Radius (ft)	Fly Length (ft)		Radius (ft)	Fly Length (ft)		Radius (ft)	Fly Length (ft)	
	28.5	51		28.5	51		28.5	51
35	9,400		35			35		
40	9,400		40			40		
45	9,400	6,200	45	9,600		45		
50	9,400	6,200	50	9,200		50	7,600	
55	8,300	6,200	55	8,600		55	7,400	
60	6,900	6,200	60	7,700	4,900	60	7,200	
65	5,800	6,100	65	6,400	4,700	65	7,000	
70	4,800	5,300	70	5,400	4,500	70	5,900	
75	4,000	4,500	75	4,500	4,300	75	4,900	3,500
80	3,300	3,800	80	3,700	4,200	80	4,100	3,400
85	2,700	3,200	85	3,100	3,900	85	3,400	3,300
90	2,200	2,600	90	2,500	3,300	90	2,800	3,300
95	1,700	2,200	95	2,000	2,800	95	2,200	3,200
100	1,300	1,700	100	1,600	2,300	100	1,700	2,800
105			105		1,900	105	1,300	2,300
110			110		1,500	110		1,900
115			115			115		1,500

This information is not for crane operation. Operator must refer to the in-cab information for crane operation. Rated lifting capacities shown on fully extended outriggers do not exceed 85% of the tipping loads and on tires do not exceed 75% of the tipping loads.

7,900 lb Counterweight – Fully Extended Outriggers – 360° Rotation (All Capacities Are Listed In Pounds)								
110 ft Main Boom Length 2° Fly Offset			110 ft Main Boom Length 20° Fly Offset			110 ft Main Boom Length 40° Fly Offset		
Radius (ft)	Fly Length (ft)		Radius (ft)	Fly Length (ft)		Radius (ft)	Fly Length (ft)	
	28.5	51		28.5	51		28.5	51
35	9,400		35			35		
40	9,400		40			40		
45	9,400	6,200	45	9,600		45		
50	9,400	6,200	50	9,200		50	7,600	
55	9,300	6,200	55	8,600		55	7,400	
60	8,200	6,200	60	8,000	4,900	60	7,200	
65	6,900	6,100	65	7,400	4,700	65	7,000	
70	5,900	5,800	70	6,500	4,500	70	6,600	
75	5,000	5,400	75	5,500	4,300	75	5,900	3,500
80	4,200	4,700	80	4,700	4,200	80	5,100	3,400
85	3,600	4,100	85	4,000	4,000	85	4,300	3,300
90	3,000	3,500	90	3,300	3,900	90	3,600	3,300
95	2,500	2,900	95	2,800	3,600	95	3,000	3,200
100	2,000	2,500	100	2,300	3,000	100	2,500	3,200
105	1,600	2,100	105	1,800	2,600	105	2,000	3,000
110	1,200	1,700	110	1,400	2,200	110	1,500	2,500
115			115		1,800	115		2,100
120			120		1,400	120		1,700
125			125			125		1,300

This information is not for crane operation. Operator must refer to the in-cab information for crane operation. Rated lifting capacities shown on fully extended outriggers do not exceed 85% of the tipping loads and on tires do not exceed 75% of the tipping loads.

Main Boom Lift Capacity Charts – Optional (Metric)

1 950kg Counterweight – Fully Extended Outriggers – 360° Rotation (All Capacities Are Listed In Kilograms)										
Radius (m)	Boom Length (m)									Radius (m)
	10.82	12.2	15.2	18.3	21.3	24.4	27.4	30.5	33.53	
3	36 290	36 290	33 300							3
3.5	35 200	34 100	30 600							3.5
4	32 600	31 450	28 300	23 050	17 150					4
4.5	30 200	29 150	26 400	21 650	17 150					4.5
5	27 700	27 300	24,700	20 200	17 150	16 050				5
6	22 200	21 950	21 600	18 000	17 150	15 700	13 100			6
7	15 750	15 900	16 150	16 250	16 350	15 700	13 100	10 850		7
8	11 850	12 100	12 300	12 450	12 500	12 600	12 450	10 850	8 800	8
9	9 250	9 500	9 800	9 900	10 000	10 050	10 100	10 100	8 800	9
10		7 650	7 950	8 100	8 150	8 200	8 250	8 300	8 300	10
12			5 500	5 700	5 750	5 800	5 850	5 900	5 900	12
14				4 150	4 250	4 300	4 350	4 400	4 400	14
16				3 050	3 200	3 250	3 300	3 300	3 350	16
18					2 400	2 450	2 500	2 550	2 550	18
20						1 850	1 950	1 950	2 000	20
22						1 400	1 450	1 500	1 500	22
24							1 050	1 100	1 150	24
26								800	800	26
28								500	550	28

This information is not for crane operation. Operator must refer to the in-cab information for crane operation. Rated lifting capacities shown on fully extended outriggers do not exceed 75% of the tipping loads and on tires do not exceed 65% of the tipping loads.

1 950kg Counterweight – On Tires – Stationary – Boom Centered Over Rear
(All Capacities Are Listed In Kilograms)

Radius (m)	Boom Length (m)						Radius (m)
	10.82	12.2	15.2	18.3	21.3	24.4	
3	18 300						3
3.5	18 300	17 150					3.5
4	14 700	14 850					4
4.5	12 100	12 250	7 900				4.5
5	10 200	10 350	7 900				5
6	7 550	7 700	7 900	6 300			6
7	5 800	5 950	6 150	6 300			7
8	4 550	4 700	4 900	5 050	4 200		8
9	3 600	3 750	3 950	4 100	4 200	4 250	9
10		3 000	3 250	3 350	3 450	3 500	10
12			2 150	2 300	2 400	2 450	12
14				1 550	1 650	1 700	14
16				1 000	1 100	1 150	16
18					700	750	18

1 950kg Counterweight – On Tires – Pick & Carry (1.6km/h) – Boom Centered Over Rear
(All Capacities Are Listed In Kilograms)

Radius (m)	Boom Length (m)						Radius (m)
	10.82	12.2	15.2	18.3	21.3	24.4	
3	16 550						3
3.5	15 300	15 400					3.5
4	14 200	14 300					4
4.5	12 100	12 250	7 900				4.5
5	10 200	10 350	7 900				5
6	7 550	7 700	7 900	6 300			6
7	5 800	5 950	6 150	6 300			7
8	4 550	4 700	4 900	5 050	4 200		8
9	3 600	3 750	3 950	4 100	4 200	4 250	9
10		3 000	3 250	3 350	3 450	3 500	10
12			2 150	2 300	2 400	2 450	12
14				1 550	1 650	1 700	14
16				1 000	1 100	1 150	16
18					700	750	18

This information is not for crane operation. Operator must refer to the in-cab information for crane operation. Rated lifting capacities shown on fully extended outriggers do not exceed 75% of the tipping loads and on tires do not exceed 65% of the tipping loads.

3 583kg Counterweight – Fully Extended Outriggers – 360° Rotation
 (All Capacities Are Listed In Kilograms)

Radius (m)	Boom Length (m)									Radius (m)
	10.82	12.2	15.2	18.3	21.3	24.4	27.4	30.5	33.53	
3	36 290	36 290	33 300							3
3.5	35 200	34 100	30 600							3.5
4	32 600	31 450	28 300	23 050	17 150					4
4.5	30 200	29 150	26 400	21 650	17 150					4.5
5	28 050	27 300	24 700	20 200	17 150	16 050				5
6	23 400	23 300	21 800	18 000	17 150	15 700	13 100			6
7	17 800	17 600	17 300	17 150	17 150	15 700	13 100	10 850		7
8	13 500	13 700	13 950	14 050	14 150	14 200	12 450	10 850	8 800	8
9	10 600	10 850	11 100	11 250	11 300	11 350	11 400	10 350	8 800	9
10		8 800	9 150	9 250	9 350	9 400	9 400	9 450	8 800	10
12			6 400	6 600	6 650	6 700	6 750	6 750	6 800	12
14				4 900	5 000	5 050	5 100	5 100	5 150	14
16				3 700	3 800	3 900	3 900	3 950	3 950	16
18					2 950	3 000	3 050	3 100	3 100	18
20						2 350	2 400	2 450	2 450	20
22						1 800	1 850	1 900	1 950	22
24							1 450	1 500	1 550	24
26								1 150	1 150	26
28								850	900	28
30									600	30

This information is not for crane operation. Operator must refer to the in-cab information for crane operation. Rated lifting capacities shown on fully extended outriggers do not exceed 75% of the tipping loads and on tires do not exceed 65% of the tipping loads.

3 583kg Counterweight – On Tires – Stationary – Boom Centered Over Rear
(All Capacities Are Listed In Kilograms)

Radius (m)	Boom Length (m)						Radius (m)
	10.82	12.2	15.2	18.3	21.3	24.4	
3	22 400						3
3.5	20 300	17 150					3.5
4	16 300	16 450					4
4.5	13 500	13 650	8 900				4.5
5	11 400	11 550	8 900				5
6	8 550	8 650	8 900	7 100			6
7	6 600	6 750	6 950	7 100			7
8	5 250	5 350	5 600	5 700	4 800		8
9	4 200	4 350	4 550	4 700	4 800	4 850	9
10		3 550	3 750	3 900	4 000	4 050	10
12			2 600	2 750	2 800	2 900	12
14				1 950	2 000	2 100	14
16				1 350	1 450	1 500	16
18					1 000	1 050	18
20						700	20

3 583kg Counterweight – On Tires – Pick & Carry (1.6km/h) – Boom Centered Over Rear
(All Capacities Are Listed In Kilograms)

Radius (m)	Boom Length (m)						Radius (m)
	10.82	12.2	15.2	18.3	21.3	24.4	
3	16 550						3
3.5	15 300	15 400					3.5
4	14 200	14 250					4
4.5	13 200	13 300	8 900				4.5
5	11 400	11 550	8 900				5
6	8 550	8 650	8 900	7 100			6
7	6 600	6 750	6 950	7 100			7
8	5 250	5 350	5 600	5 700	4 800		8
9	4 200	4 350	4 550	4 700	4 800	4 850	9
10		3 550	3 750	3 900	4 000	4 050	10
12			2 600	2 750	2 800	2 900	12
14				1 950	2 000	2 100	14
16				1 350	1 450	1 500	16
18					1 000	1 050	18
20						700	20

This information is not for crane operation. Operator must refer to the in-cab information for crane operation. Rated lifting capacities shown on fully extended outriggers do not exceed 75% of the tipping loads and on tires do not exceed 65% of the tipping loads.

Fly Attachment Lift Capacity Charts – Optional (Metric)

1 950kg Counterweight – Fully Extended Outriggers – 360° Rotation (All Capacities Are Listed In Kilograms)								
33.53m Main Boom Length 2° Fly Offset			33.53m Main Boom Length 20° Fly Offset			33.53m Main Boom Length 40° Fly Offset		
Radius (m)	Fly Length (m)		Radius (m)	Fly Length (m)		Radius (m)	Fly Length (m)	
	8.69	15.54		8.69	15.54		8.69	15.54
12	4 300		12			12		
14	4 300	2 800	14	4 300		14		
16	3 650	2 800	16	4 000		16	3 400	
18	2 850	2 800	18	3 150	2 250	18	3 300	
20	2 250	2 450	20	2 500	2 100	20	2 700	
22	1 750	1 950	22	2 000	2 000	22	2 150	1 600
24	1 350	1 600	24	1 550	1 900	24	1 700	1 550
26	1 050	1 250	26	1 200	1 550	26	1 350	1 500
28	800	950	28	900	1 250	28	1 000	1 450
30	550	750	30	650	950	30	750	1 200
32			32		750	32	500	900
34			34		550	34		700
36			36			36		500

This information is not for crane operation. Operator must refer to the in-cab information for crane operation. Rated lifting capacities shown on fully extended outriggers do not exceed 75% of the tipping loads and on tires do not exceed 65% of the tipping loads.

3 583kg Counterweight – Fully Extended Outriggers – 360° Rotation (All Capacities Are Listed In Kilograms)								
33.53m Main Boom Length 2° Fly Offset			33.53m Main Boom Length 20° Fly Offset			33.53m Main Boom Length 40° Fly Offset		
Radius (m)	Fly Length (m)		Radius (m)	Fly Length (m)		Radius (m)	Fly Length (m)	
	8.69	15.54		8.69	15.54		8.69	15.54
12	4 300		12			12		
14	4 300	2 800	14	4 300		14		
16	4 250	2 800	16	4 050		16	3 400	
18	3 400	2 800	18	3 650	2 250	18	3 300	
20	2 700	2 750	20	2 950	2 100	20	3 150	
22	2 200	2 400	22	2 400	2 000	22	2 600	1 600
24	1 750	1 950	24	1 950	1 900	24	2 100	1 550
26	1 400	1 600	26	1 550	1 800	26	1 700	1 500
28	1 100	1 300	28	1 250	1 550	28	1 350	1 450
30	850	1 050	30	950	1 250	30	1 050	1 450
32	650	800	32	750	1 000	32	800	1 200
34		600	34	500	800	34	550	950
36			36		600	36		700
38			38			38		500

This information is not for crane operation. Operator must refer to the in-cab information for crane operation. Rated lifting capacities shown on fully extended outriggers do not exceed 75% of the tipping loads and on tires do not exceed 65% of the tipping loads.

Link-Belt Construction Equipment Company Lexington, Kentucky www.linkbelt.com

®Link-Belt is a registered trademark. Copyright 2005. We are constantly improving our products and therefore reserve the right to change designs and specifications.