

385C MH

Material Handler



Engine

Engine Model	Cat® C18 ACERT™	
Net Flywheel Power	382 kW	513 hp

Weights

Operating Weight	92 616 kg	204,184 lb
• Standard MH machine with barge front and no tool		

Drive

Maximum Drawbar Pull	592 kN	133,090 lb
Maximum Travel Speed	4.4 km/h	2.8 mph

385C MH Material Handler

The Cat® 385C Material Handler is specifically designed for the scrap and material handling customer.

385C MH Two-piece Fronts by Caterpillar

The two-piece fronts meet your material handling needs with excellent lift performance and working range whether operating in close or at full reach. Built for strong performance and long service life. **pg. 4**

C18 Engine with ACERT™ Technology

- ✓ ACERT™ Technology works at the point of combustion to optimize engine performance and provide low exhaust emissions to meet U.S. EPA Tier 3 emission regulations, with exceptional performance capabilities and proven reliability. **pg. 5**

Structures

The 385C MH structural components are the backbone of the machine's durability. **pg. 6**

Complete Customer Support

Cat® Dealer services help you operate longer with lower costs. **pg. 10**

This machine uses the most sophisticated manufacturing technology to ensure the highest level of manufacturing quality. This quality, along with Cat® design standards, means that 385C Material Handler will deliver the reliability and productivity you demand from Caterpillar.



Cat® Material Handler Hydraulic Systems

The 385C MH hydraulic system is designed to handle the specific requirements of the Material Handling Industry. **pg. 7**

Additional Features

The 385C MH has been designed with many benefit adding features to enhance the machine's performance in material handling applications. **pg. 8**

Service and Maintenance

Fast, easy service has been designed in with extended service intervals, advanced filtration, convenient filter access and user-friendly electronic diagnostics for increased productivity and reduced maintenance costs. **pg. 9**



✓ *New Feature*

385C MH Two-piece Fronts by Caterpillar

The two-piece fronts meet your material handling needs with excellent lift performance and working range whether operating in close or at full reach. Built for strong performance and long service life.



Front Options. The 385C Material Handler is available with a choice of two different front lengths. The 17.2 m (56'6") front with straight boom can be used for barge unloading or scrap handling. The 22 m (71.5') can be used in scrap handling. Both front options are designed and built by Caterpillar.

Stress Relieving Booms and Sticks. Built to maximize strength and minimize structure weight.

Efficient Design of Welded Box-section Structures. The design with thick, multi-plate fabrications in high stress areas allows structures to flex, dissipating stresses and maximizing strength.

C18 Engine with ACERT™ Technology

Built for power, reliability, economy and low emissions.

Performance. The C18 with ACERT™ Technology offers 20% greater displacement than the 3406C, and runs at 10% lower speeds for better fuel economy and reduced wear. The 385C MH, equipped with a C18 engine, provides 16% more horsepower compared to the 3406C in the 375 MH.

Fuel Consumption. With ACERT Technology, the C18 engine meets U.S. EPA Tier 3 emissions regulations while delivering good fuel economy.

Emissions. ACERT Technology is a differentiated technology that reduces emissions at the point of combustion. The technology capitalizes on Caterpillar's proven leadership in three core engine systems: fuel, air and electronics.

Low Sound and Vibration Levels.

The engine mounts are rubber-isolating mounts matched with the engine package to provide optimum sound and vibration reduction. Another benefit of ACERT™ Technology, the C18 engine can shape the rate of fuel injection, a process that reduces engine noise levels and vibration.

Fuel Systems. The Cat C18 engine features electronic controls that govern the mechanically actuated unit fuel injection (MEUI) system. MEUI provides the high-pressure required to help reduce particulate emissions and deliver better fuel economy through finer fuel atomization and more complete combustion.

Cooling Systems. Standard screens at the radiator inlet along with an optional automatic reversing fan and door mounted filters keep the radiator and oil cooler clean in dirty scrap yard environments to ensure optimum cooling performance.



Air Cleaner. The radial seal air filter features a double-layered filter core for more efficient filtration and is located in a compartment behind the cab. A warning is displayed on the monitor when dust accumulates above a preset level.

Turbocharger. The Cat C18 engine uses a Wastegate Turbocharger for improved performance. This turbocharger controls the air volume to the cylinders and works efficiently during low and high load conditions.

Cold Weather Start. Starting package consists of four batteries, heavy-duty harness, large capacity starting motor and the ether starting aid. With this standard feature, the 385C MH has the capability to start at -32°C (-25.6°F).

Structures

The 385C MH structural components are the backbone of the machine's durability.



Advanced Carbody Design. Advanced carbody design stands up to the toughest applications.

- Modified X-shaped box-section carbody provides excellent resistance to torsional bending.
- When track roller frames are in working position, the lift capacity over-the-side and over-the-front are the same.
- Robotic welding helps ensure consistent, high-quality welds throughout the manufacturing process.

Thicker Carbody Plates. Thicker carbody plates, increased box-section height, and a wider carbody than found on standard excavators provide increased weight and load capacities.

Robot-welded Track Roller Frames. Press-formed, pentagonal units deliver exceptional strength and service life.

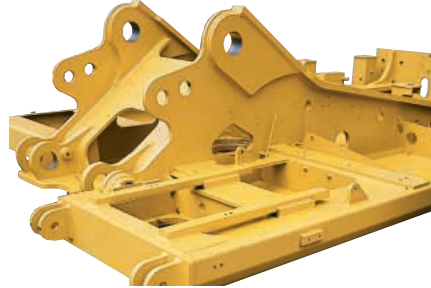

Upper Frame. Is specifically designed for the scrap and material handling market. It is built of higher strength material and thicker steel sections to handle the increased swing loads developed with the longer fronts and heavier counterweights used in material handling.

- Boom tower doubler plates add reinforcement for increased side loads and payloads.
- Box-section reinforcement of the cab outrigger frames support cab risers.
- Box-section cylinder mounts help handle increased torsional loads and payloads.

- Horizontal mounting plates provide more surface area for swing drive and swing bearing mounting bolts to handle increased loads and movement.
- Outer frame utilizes curved side rails, which are die-formed, for excellent uniformity and strength throughout the length.
- Inverted U-channels span the width of the main frame and are formed, rather than fabricated, for superior strength and reduced weight.
- Boom foot and engine mount areas are reinforced for additional strength.
- Sheet metal supporting structure is improved by integrating the mounting into upper frame structure.

Idlers. Track Idlers are positioned lower than standard excavator idlers to help better resist tipping over the front.

Cat Material Handler Hydraulic Systems

The 385C MH hydraulic system is designed to handle the specific requirements of the Material Handling Industry.

Material Handler Hydraulics.

Specifically designed to meet your hydraulic attachment requirements, the grapple open/close circuit works with the other implement circuits to deliver smooth, simultaneous, multi-function control. The rotate circuit, using main pump flow, provides a separate fully adjustable control valve that allows this configuration to meet various grapple manufacturer's flow requirements. A separate fixed displacement piston pump is used to provide the hydraulic power to run an optional 40 kW generator system.

Caterpillar 40 kW Solid State Generator

Set. Powers magnets up to 2110 mm (87") in diameter. A Caterpillar state-of-the-art electronic magnet controller and generator are linked to provide trouble free service. The new controller completely eliminates traditional contactor maintenance and it is supported and warranted through your Cat dealer.

Genset. Genset is mounted in the riser for improved protection.

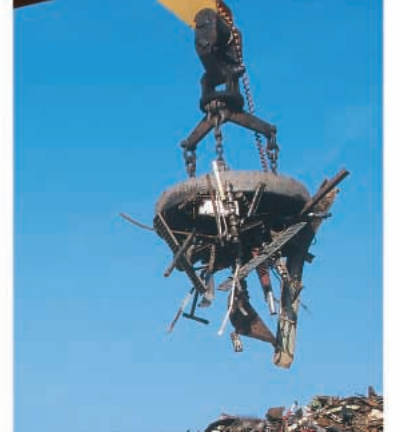

Walker Scrapmaster Series Scrap Handling Magnets. The magnets feature cast steel case and alloy steel suspension chain.

Additional Features

The 385C MH has been designed with many benefit adding features to enhance the machine's performance in material handling applications.

Smart Boom. Allows the boom to float upwards as the clamshell bucket or grapple closes. This reduces stress on the machine.

Soft Swing. Softens the deceleration portion of the swing cycle.

Automatic Reversing Fan. Reverses the engine and coolant fan to remove debris from radiator coils.



A New Cab Mounted Magnet System Monitor/Control. Provides system information to the operator through a series of indicators, lights and a rotary selector switch. The indicator lights provide the following information. Magnet "On": Magnet is turned on. Generator "Hot": Generator is overheated and must be cooled down. The generator should be run under "no load" until the indicator turns off. Voltage Fault: Voltage too high or too low. May indicate service is required. Ground Fault: The magnet, generator or cable is grounded. Service is required. Over 75% Duty Cycle: The "magnet on" time exceeds 7.5 minutes in a ten minute time frame indicating the operator technique needs to be adjusted.

Rotary Selector Switch. Allows the operator to optimize the magnet performance for different grades of scrap from within the cab.

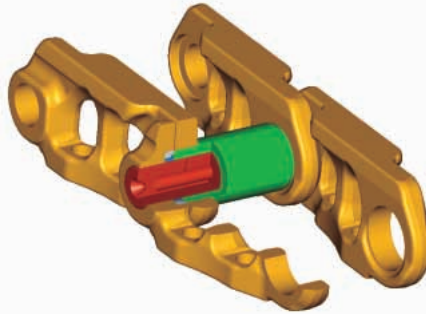

Sealed Greased Track. The 385C MH comes standard with the new grease lubricated track called GLT4. The track links are assembled and sealed with grease to decrease internal bushing wear, reduce travel noise and extend service life lowering operating costs.

Wide 4826 mm (15'10") Track Gauge. Provides over-the-side stability equal to over-the-front stability to handle heavy loads and improve productivity. Carbody plates are 5 mm thicker than standard, high strength swing bearing bolts plus larger box-section height team up to provide superior joint retention and durability in material handling applications.



Caterpillar Designed and Built, 1.9 m (6'5") Up and 1.2 m (4') Out Cab Riser.

The cab riser gets your operator to an operating height with excellent visibility for loading or unloading your processing equipment, trucks and rail cars. Access to the cab is provided by a platform which extends around the riser to allow windshield cleaning. The cab riser can also be manually tilted forward for shipping.



High Pressure Screens. High pressure screens mounted at the boom base protect the machine from contamination should the tool fail.

Service and Maintenance

Fast, easy service has been designed in with extended service intervals, advanced filtration, convenient filter access and user-friendly electronic diagnostics for increased productivity and reduced maintenance costs.

Service Intervals. Service intervals are extended to reduce maintenance costs.

- Engine oil, oil filter and fuel filters at 500 hours

Oil and Pressure Ports. Oil sample and pressure ports provide easy checking of machine condition and are standard on every machine.

Hydraulic Capsule Filters. The return filters or capsule filters for the hydraulic system are located beside the hydraulic tank. The filter elements are removable without spilling hydraulic oil.

Service Points. Service points are centrally located with easy access to facilitate routine maintenance.

Point Hydraulic System Filter.

Pilot hydraulic system filter keeps contaminants from the pilot system and is located in the pump compartment.

Greasing Points. A concentrated remote greasing block on the boom delivers grease to hard-to-reach locations.

Radial Seal Cleaner. Radial seal main air cleaner with pre-cleaner has a double-layered filter element for more efficient filtration. No tools are required to change the element.

Fuel-Water Separator. The water separator removes water from fuel, even when under pressure, and water level can be monitored in the cab.



Complete Customer Support

Cat® Dealer services help you operate longer with lower costs.



Product Support. You will find nearly all parts at our dealer parts counter. Cat dealers utilize a worldwide computer network to find in-stock parts to minimize machine downtime. You can save money with Cat remanufactured components.

Machine Selection. Make detailed comparisons of the machines you are considering before you buy. What are the job requirements, machine attachments and operating hours? What production is needed? Your Cat dealer can provide recommendations.

Purchase. Look past initial price. Consider the financing options available as well as day-to-day operating costs. This is also the time to look at dealer services that can be included in the cost of the machine to yield lower equipment owning and operating costs over the long run.

Customer Support Agreements. Cat Dealers offer a variety of product support agreements, and work with customers to develop a plan the best meets specific needs. These plans can cover the entire machine, including attachments, to help protect the customer's investment.

Maintenance Services. Repair option programs guarantee the cost of repairs up front. Diagnostic programs such as Scheduled Oil Sampling, Coolant Sampling and Technical Analysis help you avoid unscheduled repairs.

Replacement. Repair, rebuild or replace? Your Cat Dealer can help you evaluate the cost involved so you can make the right choice.

Engine

Engine Model	Cat® C18 ACERT™	
Net Flywheel Power	382 kW	513 hp
Net Power – ISO 9249	382 kW	513 hp
Net Power – SAE J1349	382 kW	513 hp
Net Power – EEC 80/1269	382 kW	513 hp
Bore	145 mm	5.7 in
Stroke	171 mm	7.2 in
Displacement	18.1 L	1,106 in ³

- The 385C MH meets worldwide Tier 3 emission requirements.
- Net power advertised is the power available at the flywheel when the engine is equipped with fan, air cleaner, muffler, and alternator.
- No engine power derating required below 2300 m (7,500 ft) altitude.

Hydraulic System

Maximum Flow (each of two pumps)	490 L/min	129 gal/min
Max. Pressure – Normal Lift	32 000 kPa	4,640 psi
Max. Pressure Travel	35 000 kPa	5,080 psi
Max. Pressure – Swing	26 000 kPa	3,770 psi
Pilot System Max. Flow	90 L/min	24 gal/min
Swing System – Maximum Flow	450 L/min	119 gal/min
Boom Cylinder Bore – Barge Front	220 mm	8.7 in
Boom Cylinder Bore – Scrap Front	220 mm	8.7 in
Boom Cylinder Stroke – Barge Front	1855 mm	73 in
Boom Cylinder Stroke – Scrap Front	1855 mm	73 in
Stick Cylinder Bore – Barge Front	220 mm	8.7 in
Stick Cylinder Bore – Scrap Front	190 mm	7.5 in
Stick Cylinder Stroke – Barge Front	1858 mm	73.2 in
Stick Cylinder Stroke – Scrap Front	1758 mm	69.2 in

Weights

Operating Weight	92 616 kg	204,184 lb
------------------	-----------	------------

- Standard MH machine with barge front and no tool

Performance

- When properly installed and maintained, the cab offered by Caterpillar, when tested with doors and windows closed according to ANSI/SAE JJ1166 OCT98, meets OSHA and MSHA requirements for operator sound exposure limits in effect at time of manufacture.
- Hearing protection may be needed when operating with an open operating station and cab (when not properly maintained or doors/windows open) for extended periods or in a noisy environment.

Swing Mechanism

Swing Torque	204.5 kN·m	150,831 lb ft
Swing Speed	6.5 rpm	

Track

Shoes (each side)	51	
Rollers (each side)	9	
Overall Track Length	749.3 mm	29.5 in
Number of Carriers Each Side	3	

Service Refill Capacities

Cooling System	101 L	26.7 gal
Engine Oil	65 L	17.2 gal
Swing Drive	19 L	5 gal
Final Drive (each)	21 L	5.6 gal
Hydraulic System (including tank)	995 L	263 gal
Hydraulic Tank	810 L	214 gal

Drive

Maximum Drawbar Pull	592 kN	133,090 lb
Maximum Travel Speed	4.4 km/h	2.8 mph

Cab

Cab/FOGS Standards	Optional operator protection guards meeting SAE J1356 and ISO 3449.
--------------------	---

Brakes

Brake Standards	Meets the following standards: SAE J1026 APR90
-----------------	--

Working Ranges

71.5' Front

Maximum horizontal reach	21.8 m	71.5'
Maximum vertical pin height	22.6 m	74.2'

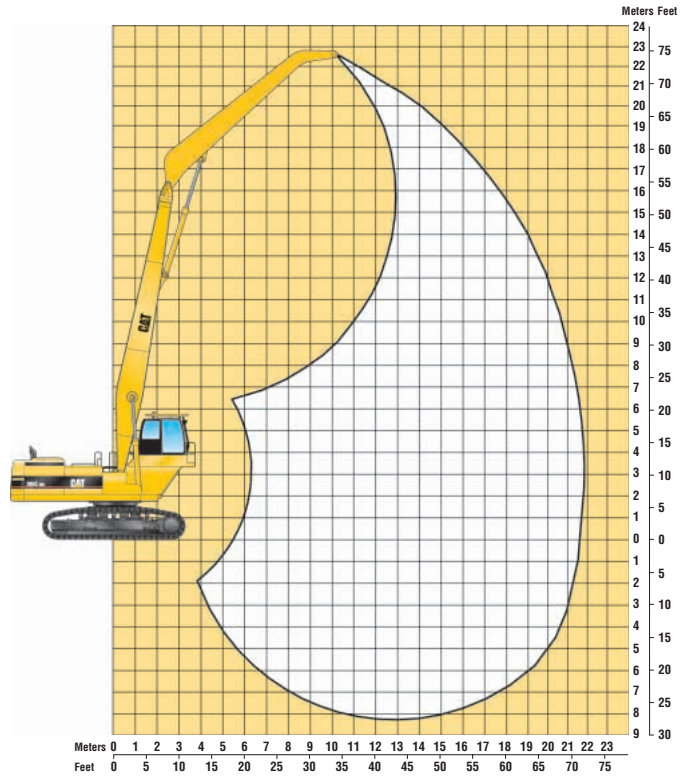

56.5' Front

Maximum horizontal reach	17.2 m	56.5'
Maximum vertical pin height	16.26 m	53.3'

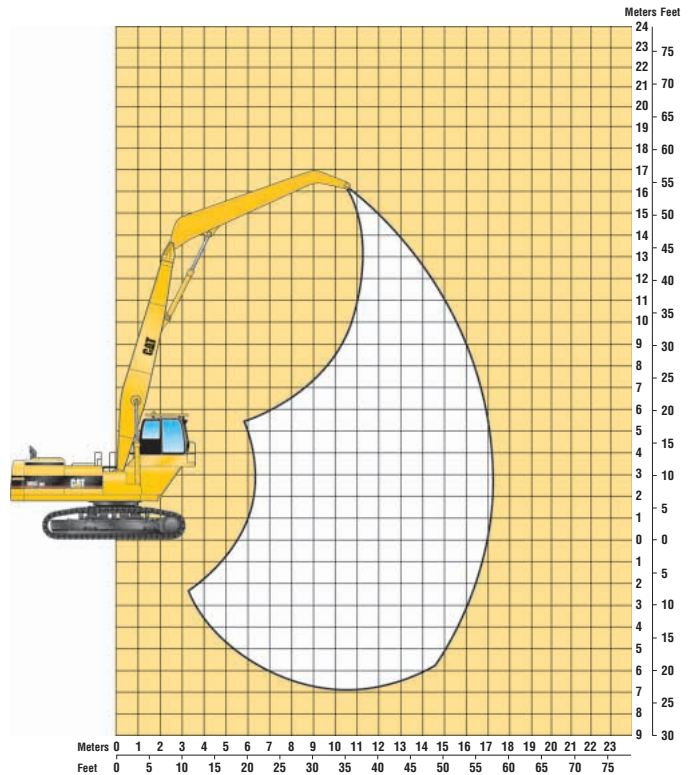

Dimensions

All dimensions are approximate.

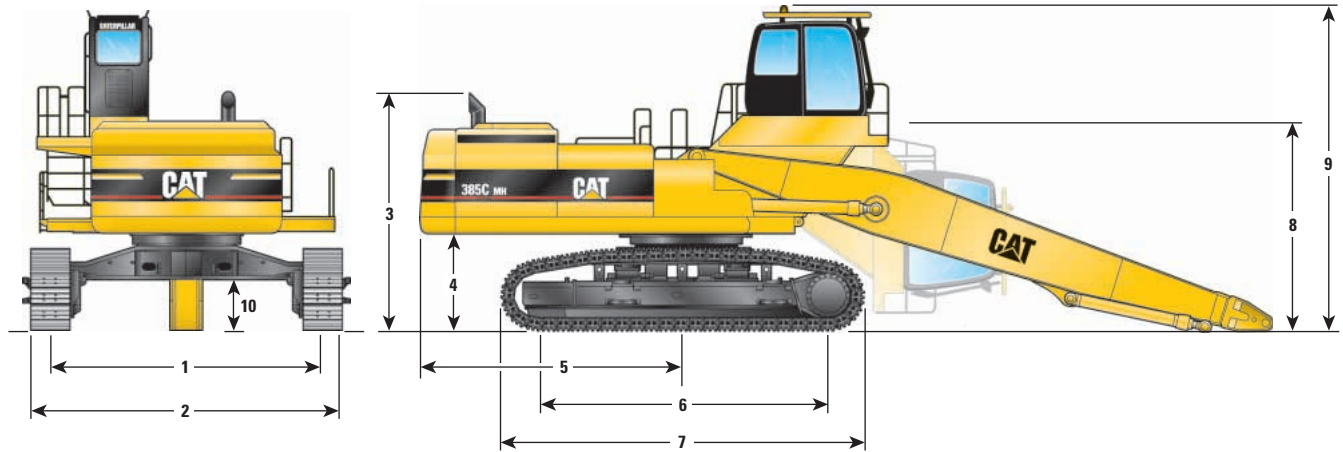

	Retracted	Extended
1 Track Gauge	4039 mm (13'3")	4826 mm (15'10")
2 Track Fully Extended	4801 mm (15'9")	5528 mm (18'4")
3 Height to Top of Exhaust	4210 mm (13'10")	4210 mm (13'10")
4 Counterweight Clearance	1699 mm (5'7")	1699 mm (5'7")
5 Tail Swing Radius	4630 mm (14'4")	4630 mm (14'4")
6 Idler to Sprocket	5131 mm (16'10")	5131 mm (16'10")
7 Overall Track Length	6350 mm (20'10")	6350 mm (20'10")
8 Shipping Height – cab tipped	4023 mm (13'2")	4023 mm (13'2")
9 Operating Height – to top of cab	5747 mm (18'10")	5747 mm (18'10")
10 Ground Clearance	850 mm (33.5")	850 mm (33.5")

Lift Capacities

385C MH – 56.5' Front

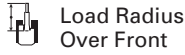

Load Point Height	4.5 m / 15.0 ft		6.0 m / 20.0 ft		7.5 m / 25.0 ft		9.0 m / 30.0 ft		10.5 m / 35.0 ft		12.0 m / 40.0 ft		13.5 m / 45.0 ft		15.0 m / 50.0 ft		16.5 m / 55.0 ft		Load at Maximum Reach						
	kg	lb	kg	lb	kg	lb	kg	lb	kg	lb	kg	lb	kg	lb	kg	lb	kg	lb	kg	lb	m	ft			
15.0 m / 50.0 ft												*13 430	*13 430							*13 020	*13 020	12.32	39.6		
13.5 m / 45.0 ft												*14 520	*14 520	*12 830	*12 830					*12 620	*12 620	13.64	44.2		
12.0 m / 40.0 ft												*15 450	*15 450	*14 150	*14 150					*12 430	*12 430	14.68	47.8		
10.5 m / 35.0 ft												*16 470	*16 470	*15 350	*15 350	*13 350	*13 350			*12 400	*12 400	15.5	50.6		
9.0 m / 30.0 ft									*18 040	*18 040	*16 870	*16 870	*15 570	*15 570	14 290	14 060			*12 510	12 390	16.15	52.8			
7.5 m / 25.0 ft								*19 190	*19 190	*17 370	*17 370	*15 860	*15 860	14 100	13 870	12 030	11 820			*11 870	*11 670	16.63	54.4		
6.0 m / 20.0 ft					*21 860	*21 860	*22 850	*22 850	*20 050	*20 050	*17 910	*17 910	*16 190	16 120	13 860	13 640	11 880	11 680			11 350	11 150	16.96	55.6	
4.5 m / 15.0 ft					*28 870	*28 870	*24 190	*24 190	*20 900	*20 900	*18 440	*18 440	16 000	15 740	13 600	13 370	11 710	11 500			11 000	10 800	17.15	56.3	
3.0 m / 10.0 ft					*30 670	*30 670	*25 310	*25 310	*21 600	*21 600	18 590	18 290	15 610	15 350	13 330	13 100	11 530	11 320			10 800	10 600	17.22	56.5	
1.5 m / 5.0 ft					*31 670	*31 670	*25 990	*25 990	21 920	21 570	18 080	17 780	15 250	14 990	13 080	12 850	11 360	11 160			10 730	10 530	17.14	56.3	
0.0 m / 0.0 ft					*7550	*7550	*21 560	*21 560	*26 070	*26 070	21 310	20 960	17 640	17 340	14 940	14 680	12 860	12 630	11 220	11 010	10 810	10 610	16.94	55.6	
-1.5 m / -5.0 ft		*3750	*3750	*8380	*8380	*18 230	*18 230	*25 460	*25 460	20 850	20 500	17 300	17 000	14 690	14 430	12 690	12 460	11 120	10 910			11 030	10 830	16.59	54.4
-3.0 m / -10.0 ft		*5810	*5810	*9930	*9930	*18 130	*18 130	*24 130	*24 130	*20 540	20 190	17 070	16 770	14 520	14 260	12 580	12 350			*11 310	*11 240	16.1	52.8		
-4.5 m / -15.0 ft				*11 830	*11 830	*19 400	*19 400	*22 040	*22 040	*18 880	*18 880	*16 190	*16 190	*13 790	*13 790	*11 440	*11 440			*10 700	*10 700	15.44	50.5		
-6.0 m / -20.0 ft				*21 590	*21 590	*19 120	*19 120	*16 470	*16 470	*14 040	*14 040	*11 670	*11 670							*23,501	*23,501				

* Rated by hydraulic capacity rather than stability capacity.

Always refer to the appropriate Operation and Maintenance Manual for specific product information.

Standard Equipment

Standard equipment may vary. Consult your Caterpillar dealer for details.

STICK AND BOOM

Choice of barge or scrap front

ELECTRICAL

75 Ampere alternator

Base machine light (Frame)

Lights, cab mounted (Two)

Horn – Signal warning

Lights, Boom (four)

OPERATOR ENVIRONMENT

Polycarbonate windows except laminated glass in retractable front windshield, 70/30 tempered glass in removable lower windshield and sliding upper door window

Heated seat, air suspension with high backseat with headrest, adjustable arm rest and retractable cloth seat belt

Monitor

Full graphic color display

Start up level check for hydraulic and engine oil and engine coolant

Working hour information

Machine condition, Error code and tool mode setting information

24V AM/FM radio with two stereo speakers (includes antennae)

Openable polycarbonate skylight with sunshade

Windshield wiper/washers (upper/lower)

Positive filtered ventilation

Air conditioner with auto climate control and defroster

Instrument panel and gauges

Hydraulic filter warning light

Interior lighting

Coat hook

Ashtray with lighter

Literature compartment

Storage compartment suitable for lunch box

Neutral lever for all controls

Joystick operated grapple/calm open and close control

Joysticks, electrically operated, adjustable with integral electrical switches for operation of grapple rotate and magnet lift drop

Toggle switch in RH console to switch between magnet and grapple operation

Travel control pedals with removable hand levers

Floor mat

Beverage holder

Bolt on FOGS capacity

Rear window exit

POWER TRAIN

Cat C18 Diesel engine with 24-volt electric starting

Emission package to meet Tier 3

Automatic engine speed control with manual return to idle

Water separator in fuel line

Water level indicator

S•O•S Sampling for engine and hydraulic systems

Two speed auto-shift travel

Dual element radiator with radiator and oil cooling side by side

Variable-speed cooling fan

Muffler

Fuel filter

High ambient cooling

UNDERCARRIAGE

Wide carbody with swivel guard

Hydraulic track adjusters

Track-type sealed undercarriage

Full length track guiding guards

750 mm (30") Triple grouser shoes (51 sections)

Grease lubricated track

Heavy duty track motor guards

HYDRAULIC SYSTEMS

Fully pressurized hydraulic system

Auxiliary pump and lines to drive generator

Medium pressure auxiliary hydraulic circuit for powering rotating grapples (includes valves and lines)

Boom based screens for grapple/bucket circuit

High pressure grapple/bucket open close hydraulic circuit

OTHER STANDARD EQUIPMENT

Heavy duty upper frame with bottom guards

Door locks, cap locks and Caterpillar one-key security system

Mirrors (Frame-right, Cab-left)

MH Counterweight

Automatic swing parking brake

Fine swing

Travel alarm

Cold weather starting aids

Sun Screen

Product link ready

Door mounted filters standard with scrap front

Automatic reversing fans

Optional Equipment

Optional equipment may vary. Consult your Caterpillar dealer for details.

Guard, Falling Objects
40 kW hydraulic driven solid state generator
Magnet, Walker
Scrapmaster Magnet

Rear Window Exit with internal and external opening latch
NOTE: This is mandatory in the province of British Columbia
Cab mounted lighting
Door mounted filters optional with barge front

Notes

385C MH Material Handler

For more complete information on Cat products, dealer services,
and industry solutions, visit us on the web at www.cat.com

© 2006 Caterpillar
All Rights Reserved
Printed in U.S.A.

Materials and specifications are subject to change without notice.
Featured machines in photos may include additional equipment.
See your Caterpillar dealer for available options.

CAT, CATERPILLAR, ACERT, their respective logos and "Caterpillar Yellow,"
as well as corporate and product identity used herein, are trademarks
of Caterpillar and may not be used without permission.

AEHQ5722 (6-06)

CATERPILLAR[®]