



M312/M315 M318/M320

Material Handler and
Industrial Arrangement



	M312	M315	M318	M320
Material Handler				
Operating Weight	–	–	20 300 kg	22 300 kg
Maximum Reach	–	–	10.5 m	11.6 m
Industrial Arrangement				
Operating Weight	13 300 kg	15 500 kg	17 600 kg	–
Maximum Reach	8 m	8.4 m	8.6 m	–

M318 MH and M320 MH Material Handler M312, M315 and M318 Industrial Arrangement

A step forward in hydraulic cab riser design

The hydraulic cab riser is designed to meet customers' needs for easier operation and greater stability. The added stability of the extra rigid design, combined with a high viewing position, helps improve operator confidence. The riser design also provides low machine height while roading. The hydraulically adjustable cab linkage is designed to reduce vibration in the cab, improving operator comfort.

1.2 meter fixed cab riser

A 1.2 m fixed cab riser is offered for the M318 and M320 standard and material handling machines, where a high viewing position is needed.

300 Family styling

The cab and body have smooth, rounded contours, and the roading lights are blended in for a modern look. Cab interior combines functional layout and pleasing color scheme.

Advanced hydraulic technology

The hydraulic system is designed specifically for material-handling applications using the most advanced hydraulic technology.



Structures

For maximum strength and reliability, all structures were designed using Finite Element Analysis (FEA) to achieve an optimum balance of weight reduction versus fatigue strength. The cab linkage was analyzed by static and dynamic methods to achieve a very stable support for the cab, with lower vibrations to the operator.

High lift capacities

The lift charts demonstrate the high lift capacities of the M300 Family material handlers. An optional "Heavy Lift" hydraulic circuit increases the pressure by 12 percent to 370 bar to achieve up to 17 percent higher lift capacities.

Exceptional ease of maintenance and serviceability

All daily maintenance points are accessible from ground level. The front attachment can be greased at ground level through a centralized greasing port.

Cat '5 Star Customer Service'

Turns your investment into profit, from purchase to resale through:

- Equipment Management Services for optimum profit
- Maintenance Services for equipment protection
- Predictive Services for optimum availability
- Reconditioning Services for lower repair cost
- Your Caterpillar dealer for satisfaction and peace of mind



M318 MH and M320 MH 1.2 m Fixed Cab Riser

M318 and M320 Material Handlers

combine the versatility of a wheel excavator with the specific purpose of a material handling machine. Material handling versions have all the features that provide standard models with superior mobility, flexibility and durability.

Standard MH models offer a straight boom, a material handling drop nose stick and extended outriggers.

The M320 MH also has a 600 kg additional counterweight.

“Heavy lift” hydraulic circuit and solid tires are available as options.

Solid tires are recommended in scrap handling applications.

Other options, such as the waste handling package and large mesh radiator, help maintain a cleaner cab and radiator in waste applications and dusty conditions.



The fixed cab riser offers a very stable and comfortable method to raise the cab. The fixed cab riser lifts the cab by 1.2 m to offer better viewing to all sides. In shipping position, the cab is unmounted to meet national road regulations.



The cab offers the same comfort and convenience as the standard cab. Well-positioned steps lead continuously from ground level to the raised cab. Sound suppression panels reduce interior sound to an industry leading level, to provide excellent operator comfort.

M300 Structure analysis

Finite Element Analysis

FEA was used to design a very stable and reliable base frame and upper structure. For maximum strength and best operating range, all linkage parts including booms and sticks, were analyzed to achieve an optimal balance of weight reduction and fatigue strength.

In addition to the static analysis of all structures, the linkage was analyzed with dynamic finite element methods.

Load cases, especially material handling applications, were developed to achieve optimal structure durability.

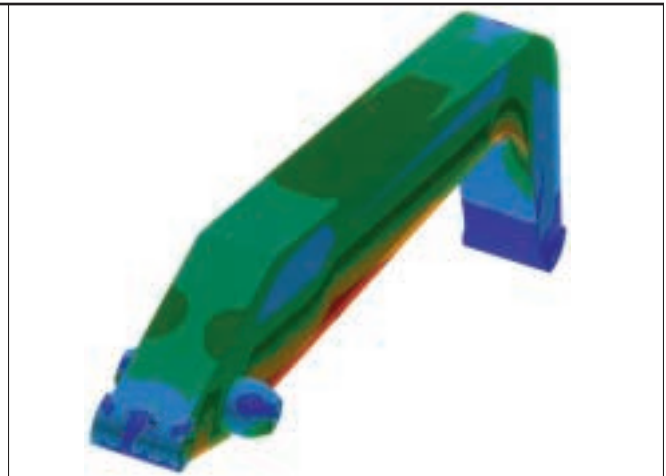

M318 MH and M320 MH Hydraulic Cab Riser

Hydraulic cab riser design

provides the most suitable solution when high flexibility in cab height is needed. The lift arms on the hydraulic cab riser are box-section designed for greater cab stability. Two heavy-duty hydraulic cylinders provide quick and controlled up and down travel.

With the cab in topmost position, the cylinders are retracted to ensure excellent stability. In the event of a hydraulic malfunction, the cab can be lowered using either a lever inside the cab or one on the frame at ground level. The linkage is a parallelogram design, which keeps the cab level in all positions.

Hydraulic cab riser in the top position

raises the cab by 2.0 meters. This provides optimal viewing to all sides in different applications such as scrap handling, log handling, and various load/unload tasks. The cab's position is infinitely variable.



Hydraulic cab riser in medium position

places the cab forward by 0.5 meters more than in the travel position, for increased visibility.



Hydraulic cab riser in bottom position

is used for shipping and travel position. When equipped with a VA boom or one-piece-boom, this is the only position allowed for travelling on public roads.



Engine

Caterpillar four-stroke-cycle, six cylinder 3116 DIT direct injection turbocharged diesel engine.

	M318 MH	M320 MH
Ratings at 2000 rpm	kW/hp	kW/hp
Gross power	104.4/140	104.4/140
Net power		
ISO 9249	98/131	98/131
EEC 80/1269	98/131	98/131

Measured Emission Values*	g/kWh	g/kWh
Hydrocarbons (HC)	0.38	0.38
Carbon Monoxide (CO)	1.32	1.32
Nitrous Oxide (NO _x)	6.20	6.20

Noise levels	dB(A)	dB(A)
	**L _{PA} = 78	**L _{PA} = 73
	**L _{WA} = 100	**L _{WA} = 102

* ISO 8178

** Dynamically measured according to ISO 6396 or 95/27/EC

Hydraulic System

Closed center, variable flow, load-sensing hydraulic system. Load-sensing axial-piston pump powers boom, stick, grapple, outriggers/dozer, and travel circuit.

Main Hydraulic System	M318 MH	M320 MH
Maximum flow	260 l/min	320 l/min
Maximum pressure		
Implements	330 bar	330 bar
Travel	330 bar	330 bar

Swing Mechanism

Dedicated variable displacement axial-piston pump and fixed-displacement axial-piston motor powers the swing mechanism.

Swing system	M318 MH	M320 MH
Maximum flow	112 l/min	112 l/min
Maximum pressure	315 bar	340 bar
Maximum swing speed	9.4 rpm	8.4 rpm

Transmission

2-gear power-shift transmission. Permanent all wheel drive.

Speeds	
1st gear, forward/reverse (work)	5 km/h
2nd gear, forward (travel)	20 km/h
2nd gear, reverse	20 km/h
Creep speed	2.8 km/h
Gradeability	61%

Service Refill Capacities

	M318 MH	M320 MH
	Liters	Liters
Fuel Tank	320	370
Cooling	35	35
Lubrication (engine)	21	21
Rear axle housing, differential	12	12
Front steering axle, differential	11	11
Final drives, front (each)	2	2
Final drives, rear (each)	1.5	1.5
Powershift transmission	3	3
Hydraulic system (including tank)	220	300
Hydraulic tank	135	205

Steering/Tires

Fully hydraulic, powered by a separate gear pump mounted on the engine.

Steering angle	35°
Standard tires	11.00-20
Optional solid tires	10.00-20

Maestro Mobile Electronic Control System

The microcontroller monitors and controls a whole set of engine and hydraulic parameters.

Axles/Brakes

Planetary axles with planetary gear reduction final drives located in the axle hubs. Fully hydraulic brake system with separate gear pump.

Axle static load capacity	40 000 kg
---------------------------	-----------

Shipping dimensions

M320 MH and M318 MH hydraulic cab riser/fixed cab riser. Dimensions include hoses and tubes.

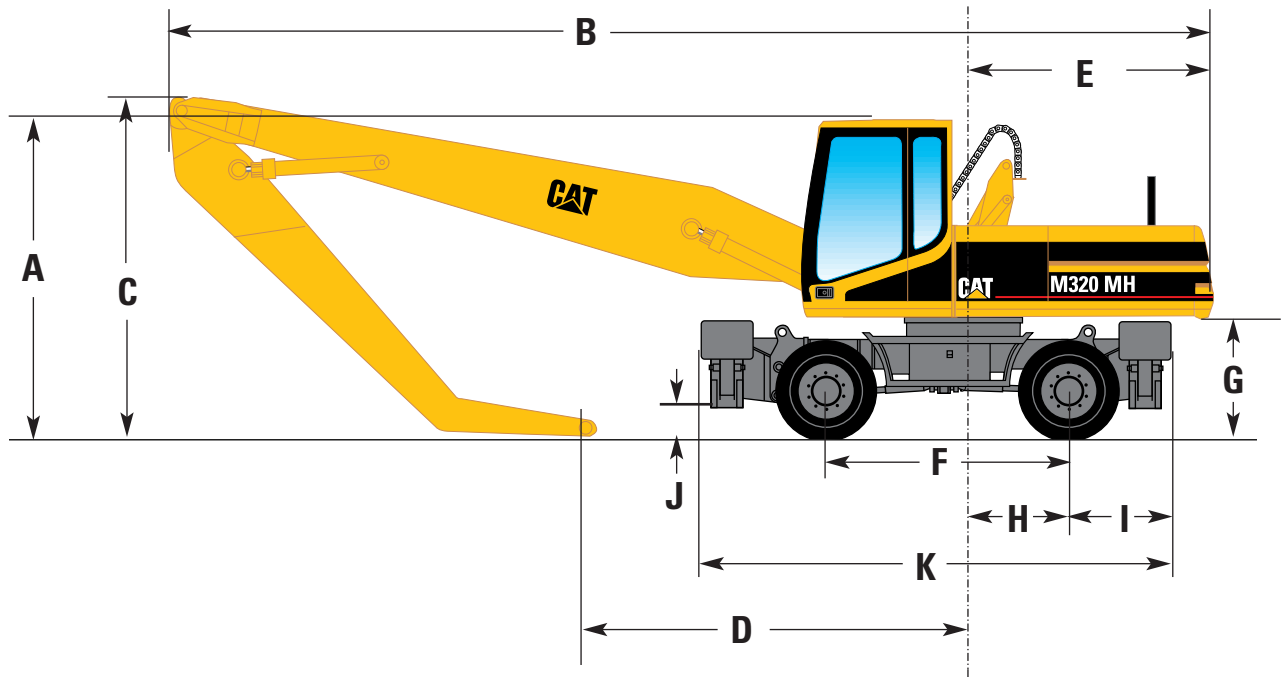

	M318 MH	M320 MH
A Cab height	3185 mm	3185 mm
B Shipping length	8890 mm	9920 mm
C Boom height	3370 mm	3350 mm
D Support point distance	3000 mm	3615 mm
E Tail swing radius	2450 mm	2700 mm
F Wheel base	2750 mm	2750 mm
G Counterweight clearance	1307 mm	1307 mm
H Swing center to rear axle	1250 mm	1250 mm
I Rear axle to stabilizer	800 mm	800 mm
J Stabilizer clearance	338 mm	338 mm
K Overall length over stabilizers	5175 mm	5175 mm
L Undercarriage width	2690 mm	2690 mm
M Stabilizer width on ground	3900 mm	4150 mm
N Overall width of upper frame	2500 mm	2650 mm

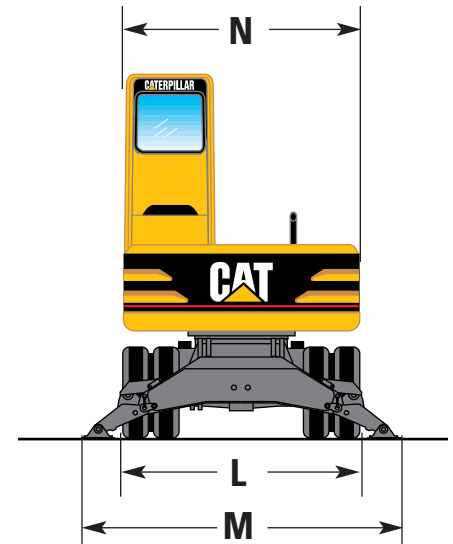

1.2 m fixed cab riser

Shipping height	*3600 mm	*3600 mm
Cab height	4350 mm	4350 mm

* Cab removed, back rest tilted forward

Working Ranges M318 MH

With Straight Boom 6.2 m and Material Handling Stick 4.5 m

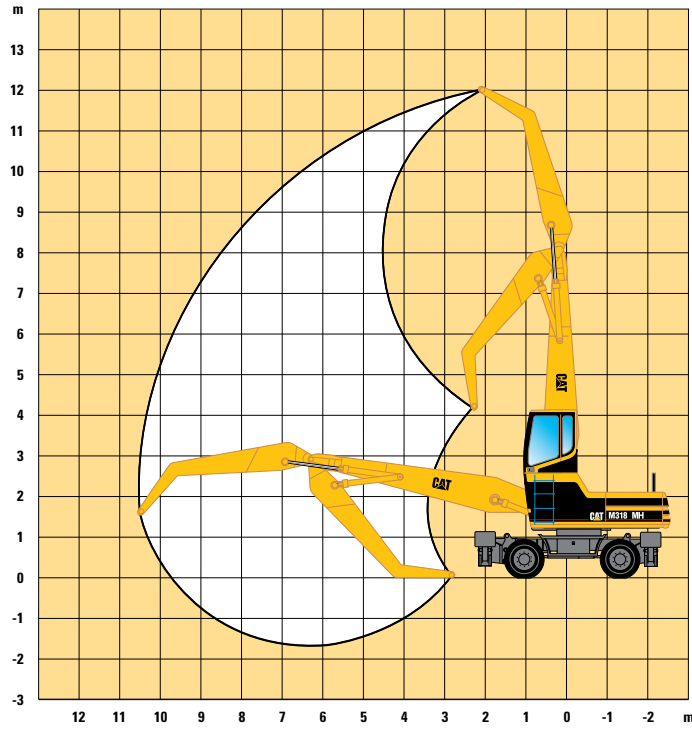





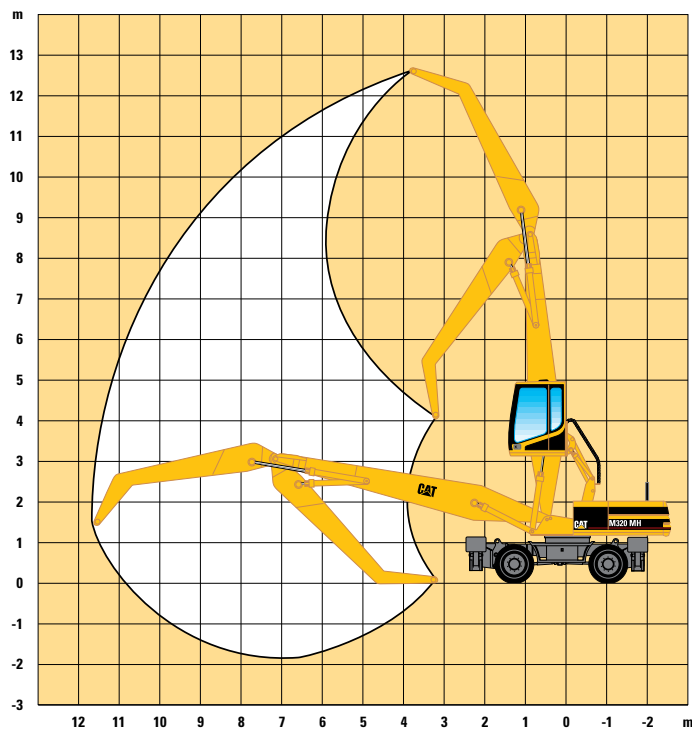







Working Ranges M320 MH

With Straight Boom 6.8 m and Material Handling Stick 4.9 m



Lift Capacities M318 MH

With Straight Boom 6.2 m and Material Handling Stick 4.5 m, front and rear stabilizers and standard tires.
All weights are in metric tons.

**Height	Undercarriage configuration	3.0 m		4.5 m		6.0 m		7.5 m		9.0 m				m
														
7.50 m	All stabilizers up					5.4	3.8	3.8	2.6			*2.1	1.9	8.9
	All stabilizers down					*6.3	*6.3	*5.1	4.8			*2.1	*2.1	
6.00 m	All stabilizers up			*7.8	5.8	5.3	3.7	3.7	2.6	2.7	1.9	*2.1	1.6	9.7
	All stabilizers down			*7.8	*7.8	*6.5	*6.5	*5.5	4.7	*4.1	3.5	*2.1	*2.1	
4.50 m	All stabilizers up	*10.4	*10.4	8.2	5.5	5.1	3.5	3.6	2.5	2.7	1.8	*2.0	1.4	10.2
	All stabilizers down	*10.4	*10.4	*8.6	*8.6	*6.8	6.6	*5.7	4.6	*4.8	3.5	*2.0	*2.0	
3.00 m	All stabilizers up			7.6	5.0	4.9	3.3	3.5	2.3	2.6	1.8	2.0	1.3	10.5
	All stabilizers down			*9.5	*9.5	*7.2	6.3	*5.8	4.5	*4.8	3.4	*2.1	*2.1	
1.50 m	All stabilizers up			7.0	4.4	4.6	3.0	3.3	2.2	2.5	1.7			
	All stabilizers down			*10.0	9.4	*7.4	6.0	*5.8	4.3	*4.7	3.3			
0.00 m	All stabilizers up	*3.7	*3.7	6.6	4.1	4.4	2.8	3.2	2.1	2.5	1.6			
	All stabilizers down	*3.7	*3.7	*9.6	9.0	*7.2	5.8	*5.6	4.2	*4.3	3.2			
-1.50 m	All stabilizers up					4.2	2.7							
	All stabilizers down					*6.3	5.6							



Load Radius
Over Front



Load Radius
Over Side



Load at
Maximum Reach













* Limited by hydraulic rather than tipping load

** Height of stick pin

The above loads are in compliance with hydraulic excavator lift capacity ratings standard ISO 10567, they do not exceed 87% of hydraulic lifting capacity or 75% of tipping capacity. Weight of all lifting accessories must be deducted from the above lift capacities

Lift Capacities M318 MH

With Straight Boom 6.2 m and Material Handling Stick 4.5 m, front and rear stabilizers and standard tires and “Heavy Lift” arrangement. All weights are in metric tons.

**Height	Undercarriage configuration	3.0 m		4.5 m		6.0 m		7.5 m		9.0 m				m
														
9.00 m	All stabilizers up					5.4	3.8							
	All stabilizers down					*6.0	*6.0							
7.50 m	All stabilizers up					5.4	3.8	3.8	2.6			*2.4	1.9	8.91
	All stabilizers down					*7.1	6.9	*5.7	4.8			*2.4	*2.4	
6.00 m	All stabilizers up			8.6	5.8	5.3	3.7	3.7	2.6	2.7	1.9	*2.3	1.6	9.71
	All stabilizers down			*8.8	*8.8	*7.3	6.8	*6.3	4.7	*4.6	3.5	*2.3	*2.3	
4.50 m	All stabilizers up	*11.7	10.6	8.2	5.5	5.1	3.5	3.6	2.5	2.7	1.8	2.2	1.4	10.23
	All stabilizers down	*11.7	*11.7	*9.7	*9.7	*7.7	6.6	*6.5	4.6	*5.5	3.5	*2.3	*2.3	
3.00 m	All stabilizers up			7.6	5.0	4.9	3.3	3.5	2.3	2.6	1.8	2.0	1.3	10.50
	All stabilizers down			*10.8	10.1	*8.2	6.3	*6.6	4.5	5.5	3.4	*2.3	*2.3	
1.50 m	All stabilizers up			7.8	5.0	5.1	3.4	3.7	2.5	2.8	1.9			
	All stabilizers down			*13.5	12.0	*9.9	7.5	*7.8	5.3	6.0	4.1			
0.00 m	All stabilizers up	*4.2	*4.2	6.6	4.1	4.4	2.8	3.2	2.1	2.5	1.6			
	All stabilizers down	*4.2	*4.2	*11.0	9.0	*8.2	5.8	*6.4	4.2	*5.0	3.2			
-1.50 m	All stabilizers up					4.2	2.7							
	All stabilizers down					*7.3	5.6							



Load Radius
Over Front



Load Radius
Over Side



Load at
Maximum Reach

* Limited by hydraulic rather than tipping load













** Height of stick pin

The above loads are in compliance with hydraulic excavator lift capacity ratings standard ISO 10567, they do not exceed 87% of hydraulic lifting capacity or 75% of tipping capacity. Weight of all lifting accessories must be deducted from the above lift capacities

Lift Capacities M320 MH

With Straight Boom 6.8 m and Material Handling Stick 4.9 m, 600 kg additional counterweight.

All weights are in metric tons.

**Height	Undercarriage configuration	3.0m		4.5m		6.0m		7.5m		9.0m				m
														
7.50 m	All stabilizers up					6.3	4.5	4.4	3.1	3.2	2.2	2.6	1.8	10.10
	All stabilizers down					*7.1	*7.1	*6.2	6.0	*5.4	4.5	*2.8	*2.8	
6.00 m	All stabilizers up					6.2	4.3	4.3	3.0	3.2	2.2	2.3	1.5	10.81
	All stabilizers down					*7.4	*7.4	*6.3	5.9	*5.5	4.4	*2.8	*2.8	
4.50 m	All stabilizers up			9.4	6.3	5.9	4.1	4.1	2.9	3.1	2.1	2.1	1.4	11.28
	All stabilizers down			*10.1	*10.1	*7.9	*7.9	*6.5	5.8	*5.5	4.3	*2.7	*2.7	
3.00 m	All stabilizers up			8.6	5.6	5.5	3.7	3.9	2.7	3.0	2.0	2.0	1.3	11.53
	All stabilizers down			*11.2	*11.2	*8.4	7.9	*6.7	5.6	*5.6	4.2	*2.8	*2.8	
1.50 m	All stabilizers up			7.9	5.0	5.1	3.4	3.7	2.5	2.8	1.9			
	All stabilizers down			*11.8	*11.8	*8.6	7.5	*6.8	5.3	*5.5	4.1			
0.00 m	All stabilizers up			7.4	4.6	4.9	3.2	3.6	2.3	2.8	1.8			
	All stabilizers down			*10.8	*10.8	*8.4	7.2	*6.6	5.2	*5.2	4.0			
-1.50 m	All stabilizers up					4.7	3.0	3.5	2.2					
	All stabilizers down					*7.5	7.0	*5.9	5.1					



Load Radius Over Front



Load Radius Over Side



Load at Maximum Reach

* Limited by hydraulic rather than tipping load













** Height of stick pin

The above loads are in compliance with hydraulic excavator lift capacity ratings standard ISO 10567, they do not exceed 87% of hydraulic lifting capacity or 75% of tipping capacity. Weight of all lifting accessories must be deducted from the above lift capacities

Lift Capacities M320 MH

With Straight Boom 6.8 m and Material Handling Stick 4.9 m, 600 kg additional counterweight, "Heavy Lift" arrangement.

All weights are in metric tons.

**Height	Undercarriage configuration	3.0m		4.5m		6.0m		7.5m		9.0m				m
														
9.00 m	All stabilizers up					6.4	4.5	4.4	3.1	3.2	2.2			
	All stabilizers down					*8.0	*8.0	*7.0	6.1	*3.8	*3.8			
7.50 m	All stabilizers up					6.3	4.5	4.4	3.1	3.2	2.2	2.6	1.7	10.10
	All stabilizers down					*8.1	*8.1	*7.0	6.0	*6.2	4.4	*3.2	*3.2	
6.00 m	All stabilizers up					6.2	4.3	4.3	3.0	3.2	2.2	2.3	1.5	10.81
	All stabilizers down					*8.4	*8.4	*7.2	5.9	*6.2	4.4	*3.1	*3.1	
4.50 m	All stabilizers up			9.4	6.3	5.9	4.1	4.1	2.9	3.1	2.1	2.1	*1.4	11.28
	All stabilizers down			11.4	*11.4	*9.0	8.3	*7.4	5.8	6.2	4.3	*3.1	3.0	
3.00 m	All stabilizers up			8.6	5.6	5.5	3.7	3.9	2.7	3.0	2.0	2.0	1.3	11.53
	All stabilizers down			*12.7	12.7	*9.5	7.9	*7.7	5.6	6.1	4.2	*3.2	2.8	
1.50 m	All stabilizers up			7.8	5.0	5.1	3.4	3.7	2.5	2.8	1.9			
	All stabilizers down			*13.5	12.0	*9.9	7.5	*7.8	5.3	6.0	4.1			
0.00 m	All stabilizers up			7.4	4.6	4.9	3.1	3.6	2.3	2.7	1.8			
	All stabilizers down			*12.1	11.4	*9.6	7.2	*7.5	5.2	5.9	4.0			
-1.50 m	All stabilizers up					4.7	3.0	3.4	2.2					
	All stabilizers down					*8.7	7.0	*6.8	5.1					



Load Radius Over Front



Load Radius Over Side



Load at Maximum Reach

* Limited by hydraulic rather than tipping load

** Height of stick pin

The above loads are in compliance with hydraulic excavator lift capacity ratings standard ISO 10567, they do not exceed 87% of hydraulic lifting capacity or 75% of tipping capacity. Weight of all lifting accessories must be deducted from the above lift capacities

M312, M315 and M318 Industrial Arrangement

Industrial sticks

Two boom/stick configurations are available for each of the M300 Family machines. The industrial stick can be attached to either the one-piece-boom or the hydraulically adjustable VA boom to better meet application needs.

M318 wide gauge undercarriage

The wide gauge undercarriage, available for the M318, gives more stability to the machine when working at long reach, over the side without stabilizers. Width of the wide gauge axles is 2.68 meters, making them 7 percent wider than the standard undercarriage. A 2.75 meter dozer blade, compared to the standard 2.5 meter blade, is also available.



Engine

Caterpillar four-stroke-cycle, four cylinder 3054 DITA direct injection turbocharged diesel engine (M312 and M315). Caterpillar four-stroke-cycle, six cylinder 3116 DIT direct injection turbocharged diesel engine (M318).

	M312	M315	M318
Ratings at 2000 rpm	kW/hp	kW/hp	kW/hp
Gross power	85.1/114	92.4/124	103.5/139

The following ratings apply at 2000 rpm when tested under the conditions for the specified standard:

Net power	kW/hp	kW/hp	kW/hp
ISO 9249	81.1/108.7	83.8/112	98/131
EEC 80/1269	81.1/108.7	83.8/112	98/131

Dimensions

Bore	100 mm	100 mm	102 mm
Stroke	127 mm	127 mm	130 mm
Displacement	3.99 liters	3.99 liters	6.6 liters
Maximum torque	450 Nm	450 Nm	608 Nm
Torque rise	8% at 1400 rpm	16% at 1500 rpm	21% at 1500 rpm
Noise levels	*L _{PA} = 72 dB(A) *L _{WA} = 99 dB(A)	*L _{PA} = 75 dB(A) *L _{WA} = 99 dB(A)	*L _{PA} = 78 dB(A) *L _{WA} = 100 dB(A)

Measured Emission Values**	g/hph	g/hph	g/hph
Hydrocarbons (HC)	0.212	0.212	0.38
Carbon Monoxide (CO)	0.511	0.511	1.32
Nitrous Oxide (NO _x)	8.113	8.113	6.20

* Dynamically measured according to ISO6396 or 95/27/EC.

** ISO 8178

Axles/Brakes

Planetary axles with planetary gear reduction final drives located in the axle hubs. Fully hydraulic brake system with separate gear pump.

Axle static load capacity	
M312	26 000 kg
M315/M318	30 000 kg

Steering/Tires

Fully hydraulic, powered by a separate gear pump mounted on the engine.

Steering angle	35°
Standard tires	10.00-20
Optional solid tires	10.00-20

Maestro Mobile Electronic Control System

The microcontroller monitors and controls a whole set of engine and hydraulic parameters.

Hydraulic System

Closed center, variable flow, load-sensing hydraulic system. Load-sensing axial-piston pump powers boom, stick, bucket, outriggers/dozer and travel circuit.

Main Hydraulic System	M312	M315	M318
Maximum flow	190 l/min	220 l/min	260 l/min
Maximum pressure			
Implements	330 bar	330 bar	330 bar
Travel	330 bar	330 bar	330 bar

Pilot System

Maximum flow	15 l/min	15 l/min	15 l/min
Maximum pressure	25 bar	30 bar	25 bar

Swing Mechanism

Dedicated variable displacement axial-piston pump and fixed-displacement axial-piston motor powers the swing mechanism.

	M312	M315	M318
Swing system			
Maximum flow	80 l/min	80 l/min	112 l/min
Maximum pressure	350 bar	370 bar	315 bar
Swing torque	31 kNm	36.5 kNm	46.4 kNm
Maximum swing speed	11 rpm	10.1 rpm	9.4 rpm

Transmission

2-gear power-shift transmission. Permanent all wheel drive.

Speeds	M312	M315	M318
1st gear forward/reverse (work)	9 km/h	9 km/h	9 km/h
2nd gear forward (travel)	34 km/h	34 km/h	34 km/h
2nd gear reverse	20 km/h	20 km/h	20 km/h
Creeper speed	3.8 km/h	3.8 km/h	3.8 km/h
Drawbar pull	70 kN	91 kN	91 kN
Gradeability	57%	67%	61%

Service Refill Capacities

	M312 Liters	M315 Liters	M318 Liters
Fuel Tank	230	240	320
Cooling	35	30	35
Lubrication (engine)	9	9	21
Rear axle housing, differential	11	11	11
Front steering axle, differential	7	8.5	8.5
Final drives, front (each)	2	2	2
Final drives, rear (each)	2	2	2
Powershift transmission	3	3	3
Hydraulic system (including tank)	180	210	220
Hydraulic tank	95	115	135

Shipping Dimensions

Including hoses and tubes.

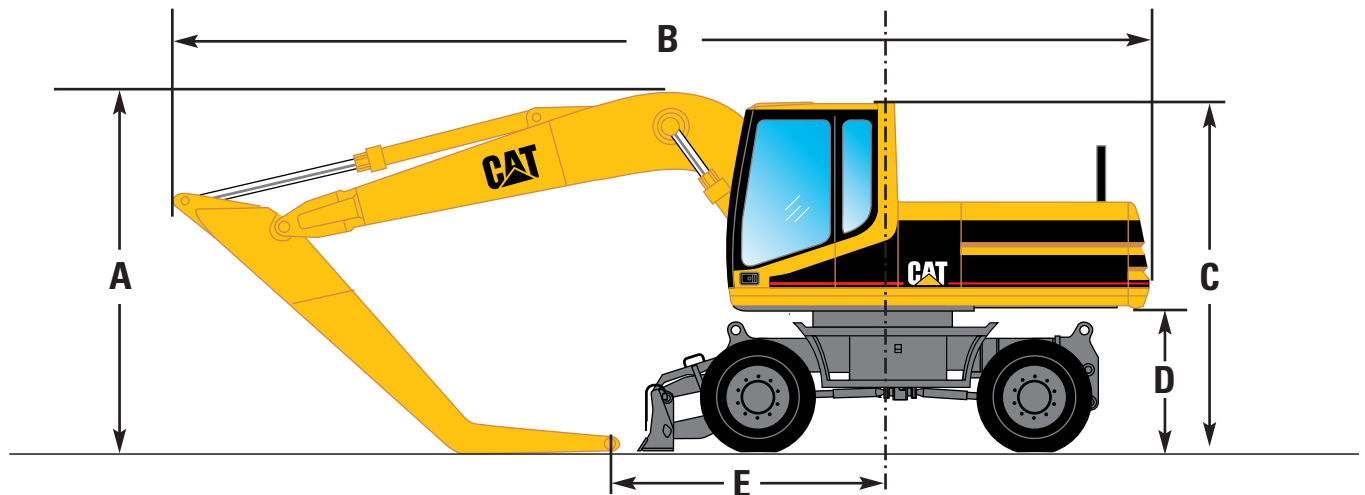

	One-piece boom			VA boom		
	M312	M315	M318	M312	M315	M318
A Shipping height	3070 mm	3080 mm	3160 mm	3070 mm	3130 mm	3220 mm
B Shipping length	7870 mm	8260 mm	9010 mm	8120 mm	8470 mm	8920 mm
C Cab height	3070 mm	3080 mm	3100 mm	3070 mm	3080 mm	3100 mm
D Counterweight clearance	1262 mm	1262 mm	1280 mm	1262 mm	1262 mm	1280 mm
E Support point distance	3220 mm	3290 mm	3440 mm	3550 mm	3720 mm	3535 mm





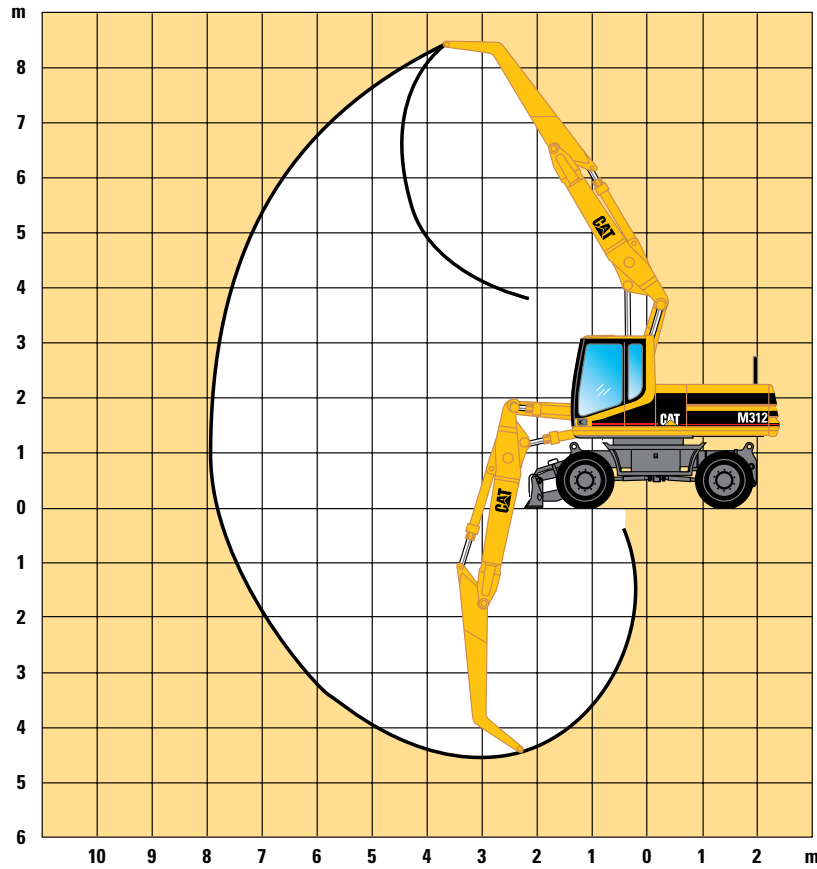







Working Ranges M312 VA boom

With VA boom 5.25 m and industrial stick 2.8 m.



Lift capacities M312 VA boom

With 400 kg additional counterweight and “heavy lift” arrangement. All weights are in metric tons.

**Height	Undercarriage configuration	3.0 m		4.5 m		6.0 m		7.5 m		9.0 m				m
														
6.00 m	All stabilizers up			*3.1	*3.1	*2.9	2.3							
	All stabilizers down			*3.1	*3.1	*2.9	*2.9							
4.50 m	All stabilizers up			*3.5	*3.5	*3.4	2.3							
	All stabilizers down			*3.5	*3.5	*3.4	*3.4							
3.00 m	All stabilizers up	*7.5	5.8	*5.0	3.3	3.4	2.3	2.5	1.6			*2.0	1.4	7.88
	All stabilizers down	*7.5	*7.5	*5.0	*5.0	*4.1	*4.1	*2.9	*2.9			*2.0	*2.0	
1.50 m	All stabilizers up	*7.8	5.7	5.0	3.3	3.4	2.3	2.4	1.5			*2.1	1.4	7.98
	All stabilizers down	*7.8	*7.8	*6.1	*6.1	*4.6	4.1	*3.5	3.0			*2.1	*2.1	
0.00 m	All stabilizers up	*9.3	*5.8	5.1	3.3	3.4	2.1	2.4	1.5			2.2	1.4	7.78
	All stabilizers down	*9.3	*9.3	*6.7	6.2	*4.9	4.2	*3.5	2.9			*2.3	*2.3	
-1.50 m	All stabilizers up	9.7	5.5	5.1	3.1	3.2	2.0					2.4	1.5	7.25
	All stabilizers down	*10.5	*10.5	*6.8	6.3	*5.0	4.0					*2.8	*2.8	
-3.00 m	All stabilizers up	9.8	5.4	4.9	2.9	3.1	1.9					2.9	1.8	6.32
	All stabilizers down	*10.9	*10.9	*6.9	6.3	*4.5	4.0					*3.7	3.7	
-4.50 m	All stabilizers up	*8.7	5.2											
	All stabilizers down	*8.7	*8.7											



Load Radius Over Front



Load Radius Over Side



Load at Maximum Reach

* Limited by hydraulic rather than tipping load

** Height of stick pin

The above loads are in compliance with hydraulic excavator lift capacity ratings standard ISO 10567, they do not exceed 87% of hydraulic lifting capacity or 75% of tipping capacity. Weight of all lifting accessories must be deducted from the above lift capacities





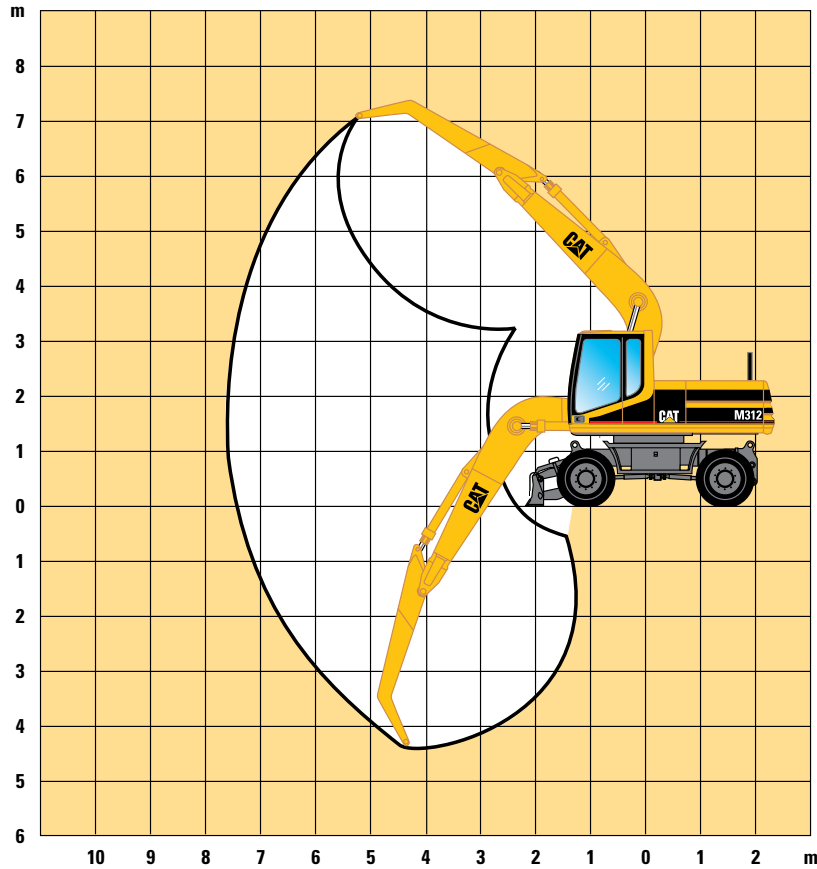







Working Ranges M312 One-piece-boom

With One-piece-boom 5.05 m and industrial stick 2.8 m.



Lift capacities M312 One-piece-boom

With 400 kg additional counterweight and “heavy lift” arrangement. All weights are in metric tons.

**Height	Undercarriage configuration	3.0 m		4.5 m		6.0 m		7.5 m		9.0 m				m
														
6.00 m	All stabilizers up					*2.5	2.3							
	All stabilizers down					*2.5	*2.5							
4.50 m	All stabilizers up					*3.3	2.2							
	All stabilizers down					*3.3	*3.3							
3.00 m	All stabilizers up	*7.2	5.7	*5.0	3.2	3.4	2.1	*2.2	1.6			*2.0	1.5	
	All stabilizers down	*7.2	*7.2	*5.0	*5.0	*4.1	*4.1	*2.2	*2.2			*2.2	*2.2	7.56
1.50 m	All stabilizers up	*4.9	*4.9	4.9	3.0	3.3	2.1	2.4	1.5			*2.2	1.5	
	All stabilizers down	*4.9	*4.9	*6.1	*6.1	*4.6	4.1	*2.7	*2.7			*2.2	*2.2	7.66
0.00 m	All stabilizers up			4.8	2.9	3.2	2.0					2.4	1.5	
	All stabilizers down			*6.8	6.1	*5.0	4.0					*2.5	*2.5	7.45
-1.50 m	All stabilizers up	*7.1	4.9	4.7	2.8	3.1	1.9					2.6	1.6	
	All stabilizers down	*7.1	*7.1	*6.8	6.0	*5.0	3.9					*3.0	*3.0	6.90
-3.00 m	All stabilizers up	*8.8	5.0	4.7	2.8							3.2	2.0	
	All stabilizers down	*8.8	*8.8	*6.1	6.0							*4.3	4.0	5.91



Load Radius Over Front



Load Radius Over Side

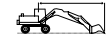

Load at Maximum Reach

* Limited by hydraulic rather than tipping load

** Height of stick pin

The above loads are in compliance with hydraulic excavator lift capacity ratings standard ISO 10567, they do not exceed 87% of hydraulic lifting capacity or 75% of tipping capacity. Weight of all lifting accessories must be deducted from the above lift capacities





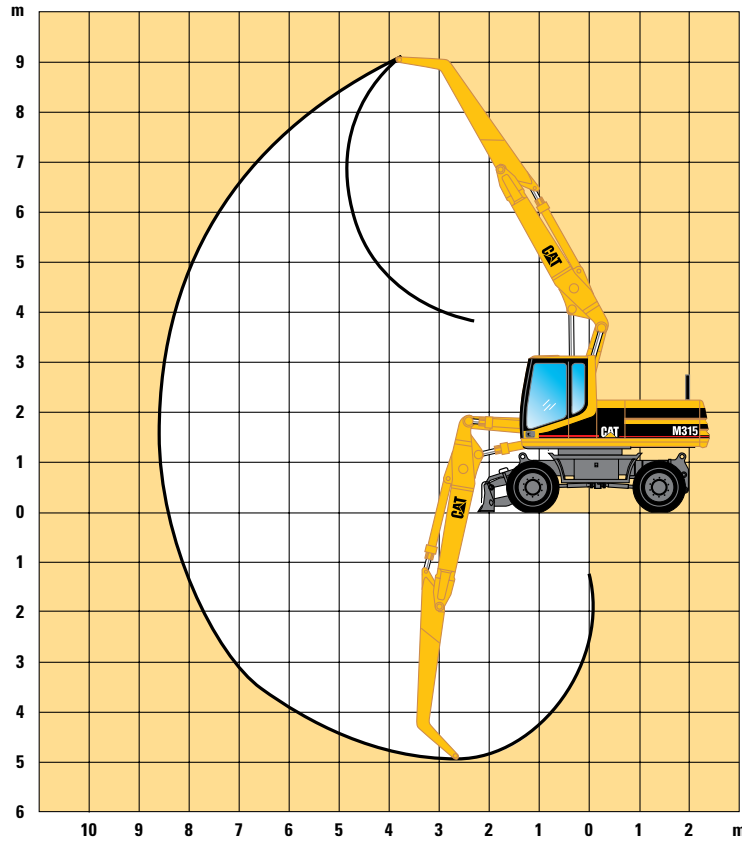







Working Ranges M315 VA boom

With VA boom 5.25 m and industrial stick 3.0 m.



Lift capacities M315 VA boom

With 400 kg additional counterweight and “heavy lift” arrangement. All weights are in metric tons.

**Height	Undercarriage configuration	3.0 m		4.5 m		6.0 m		7.5 m		9.0 m				m
														
6.00 m	All stabilizers up					*3.2	2.8							
	All stabilizers down					*3.2	*3.2							
4.50 m	All stabilizers up			*3.6	*3.6	*3.6	2.8	*2.8	2.0					
	All stabilizers down			*3.6	*3.6	*3.6	*3.6	*2.8	*2.8					
3.00 m	All stabilizers up	*9.0	7.0	*5.9	4.1	4.1	2.8	3.0	2.0			*2.1	1.6	8.29
	All stabilizers down	*9.0	*9.0	*5.9	*5.9	*4.8	*4.8	*3.6	*3.6			*2.1	*2.1	
1.50 m	All stabilizers up	*8.7	6.9	6.0	4.0	*4.1	2.8	2.9	1.9			*2.2	1.6	8.38
	All stabilizers down	*8.7	*8.7	*7.3	*7.3	*5.4	5.0	*4.3	3.6			*2.2	*2.2	
0.00 m	All stabilizers up	*10.1	6.8	6.0	4.0	4.0	2.7	2.8	1.8			*2.4	1.6	8.18
	All stabilizers down	*10.1	*10.1	*8.1	7.5	*5.9	5.0	*4.7	3.6			*2.4	*2.4	
-1.50 m	All stabilizers up	11.5	6.6	6.1	3.8	3.9	2.5	2.8	1.7			2.7	1.7	7.68
	All stabilizers down	*12.2	*12.2	*8.2	7.6	*6.0	4.9	*3.7	3.5			*2.8	*2.8	
-3.00 m	All stabilizers up	11.7	6.5	5.9	3.6	3.8	2.4					3.2	2.0	6.80
	All stabilizers down	*13.2	*13.2	*8.4	7.6	*5.8	4.8					*3.6	*3.6	
-4.50 m	All stabilizers up	11.4	6.3	5.7	3.5									
	All stabilizers down	*12.0	*12.0	*6.7	*6.7									



Load Radius Over Front



Load Radius Over Side



Load at Maximum Reach

* Limited by hydraulic rather than tipping load

** Height of stick pin

The above loads are in compliance with hydraulic excavator lift capacity ratings standard ISO 10567, they do not exceed 87% of hydraulic lifting capacity or 75% of tipping capacity. Weight of all lifting accessories must be deducted from the above lift capacities

Working Ranges M315 One-piece-boom

With One-piece-boom 5.05 m and industrial stick 3.0 m.

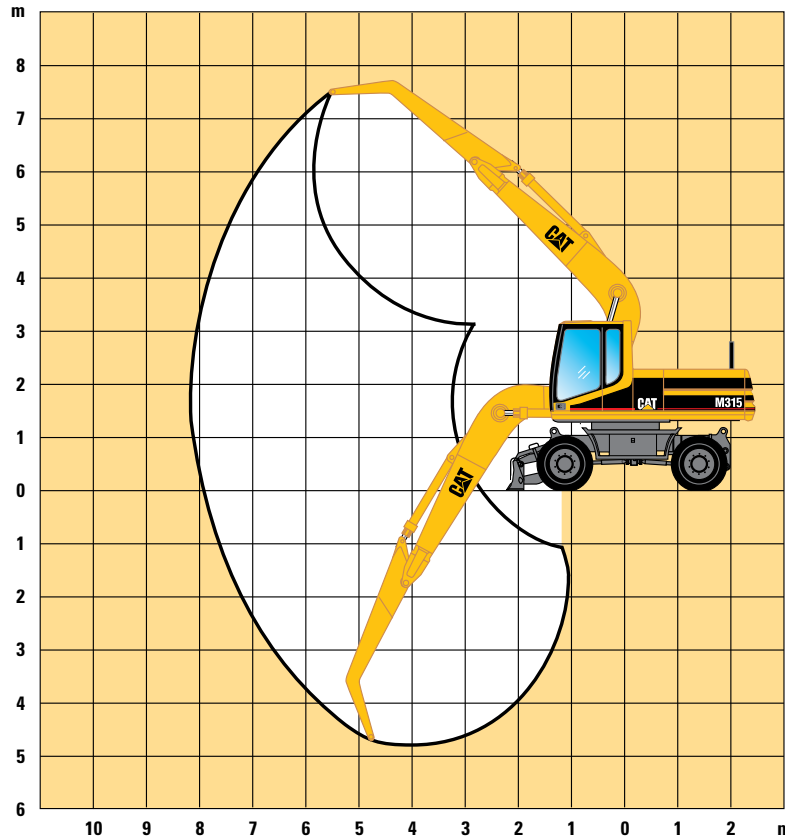

Lift capacities M315 One-piece-boom

With 400 kg additional counterweight and “heavy lift” arrangement. All weights are in metric tons.

**Height	Undercarriage configuration	3.0m		4.5m		6.0m		7.5m		9.0m		m
6.00m	All stabilizers up					*3.1	2.8					
	All stabilizers down					*3.1	*3.1					
4.50m	All stabilizers up					*3.6	2.7	*2.4	1.9			
	All stabilizers down					*3.6	*3.6	*2.4	*2.4			
3.00m	All stabilizers up	*8.7	6.9	*6.0	3.9	4.0	2.6	2.9	1.9		*2.2	1.7
	All stabilizers down	*8.7	*8.7	*6.0	*6.0	*4.7	*4.7	*3.2	*3.2		*2.2	*2.2
1.50m	All stabilizers up			5.8	3.6	3.9	2.5	2.9	1.9		*2.3	1.7
	All stabilizers down			*7.4	*7.4	*5.5	4.9	*3.9	3.6		*2.3	*2.3
0.00m	All stabilizers up	*4.9	*4.9	5.7	3.5	3.8	2.4	2.8	1.8		*2.6	1.7
	All stabilizers down	*4.9	*4.9	*8.2	7.4	*6.0	4.8	*4.0	3.5		*2.6	*2.6
-1.50m	All stabilizers up	*7.2	5.9	5.6	3.4	3.7	2.4				2.8	1.8
	All stabilizers down	*7.2	*7.2	*8.3	7.3	*6.1	4.8				*3.1	*3.1
-3.00m	All stabilizers up	11.0	6.0	5.6	3.4	3.7	2.4				3.4	2.2
	All stabilizers down	*11.0	*11.0	*7.6	7.3	*5.5	4.8				*4.2	*4.2
-4.50m	All stabilizers up	*7.9	6.2	*5.4	3.5							
	All stabilizers down	*7.9	*7.9	*5.4	*5.4							



Load Radius Over Front



Load Radius Over Side

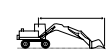

Load at Maximum Reach

* Limited by hydraulic rather than tipping load

** Height of stick pin

The above loads are in compliance with hydraulic excavator lift capacity ratings standard ISO 10567, they do not exceed 87% of hydraulic lifting capacity or 75% of tipping capacity. Weight of all lifting accessories must be deducted from the above lift capacities





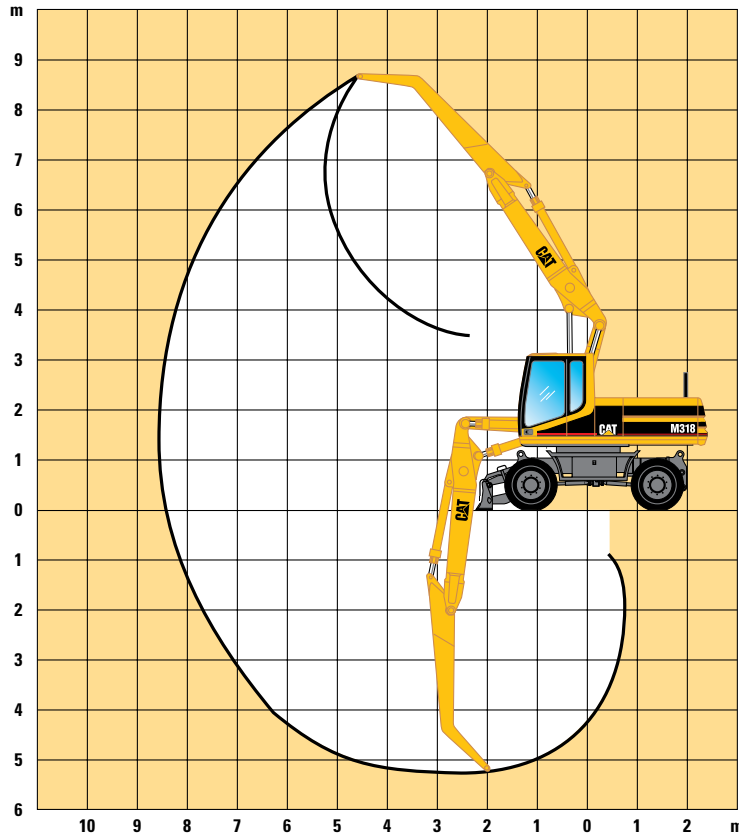







Working Ranges M318 VA boom

With VA boom 5.25 m and industrial stick 3.2 m



Lift capacities M318 VA boom

With 400 kg additional counterweight and “heavy lift” arrangement. All weights are in metric tons.

**Height	Undercarriage configuration	3.0 m		4.5 m		6.0 m		7.5 m		9.0 m				m
														
6.00 m	All stabilizers up					*3.9	3.4							
	All stabilizers down					*3.9	*3.9							
4.50 m	All stabilizers up			*4.4	3.4	3.7	2.4							
	All stabilizers down			*4.4	*4.4	*4.1								
3.00 m	All stabilizers up	*9.1	8.3	*6.2	*4.8	5.1	3.3	3.8	2.4			*2.6	1.9	8.46
	All stabilizers down	*9.1	*9.1	*6.2	*6.2	*5.1	*5.1	*4.7	4.3			*2.6	*2.6	
1.50 m	All stabilizers up	*10.6	8.1	*7.5	4.7	*5.0	3.3	3.7	2.3			*2.8	1.8	8.54
	All stabilizers down	*10.6	*10.6	*8.0	*8.0	*6.0	5.8	*5.1	4.3			*2.8	*2.8	
0.00 m	All stabilizers up	*12.2	*8.1	7.5	4.7	5.0	3.2	3.6	2.2			3.0	1.8	8.34
	All stabilizers down	*12.2	*12.2	*9.2	8.6	*6.7	5.8	*5.5	4.2			*3.1	*3.1	
-1.50 m	All stabilizers up	*14.4	7.9	*7.6	4.5	4.9	3.0	3.5	2.1			3.2	1.9	7.85
	All stabilizers down	*14.4	*14.4	*9.7	8.8	*7.1	5.8	*5.6	4.1			*3.6	*3.6	
-3.00 m	All stabilizers up	14.9	7.7	7.5	4.3	4.7	2.8					3.8	2.2	6.99
	All stabilizers down	*15.5	*15.5	*9.8	8.9	*7.2	5.6					*4.6	4.5	
-4.50 m	All stabilizers up	14.9	7.5	7.2	4.1									
	All stabilizers down	*15.3	*15.3	*9.0	8.7									



Load Radius Over Front



Load Radius Over Side



Load at Maximum Reach

* Limited by hydraulic rather than tipping load

** Height of stick pin

The above loads are in compliance with hydraulic excavator lift capacity ratings standard ISO 10567, they do not exceed 87% of hydraulic lifting capacity or 75% of tipping capacity. Weight of all lifting accessories must be deducted from the above lift capacities

Working Ranges M318 One-piece-boom

With One-piece-boom 5.3 m and industrial stick 3.2 m.

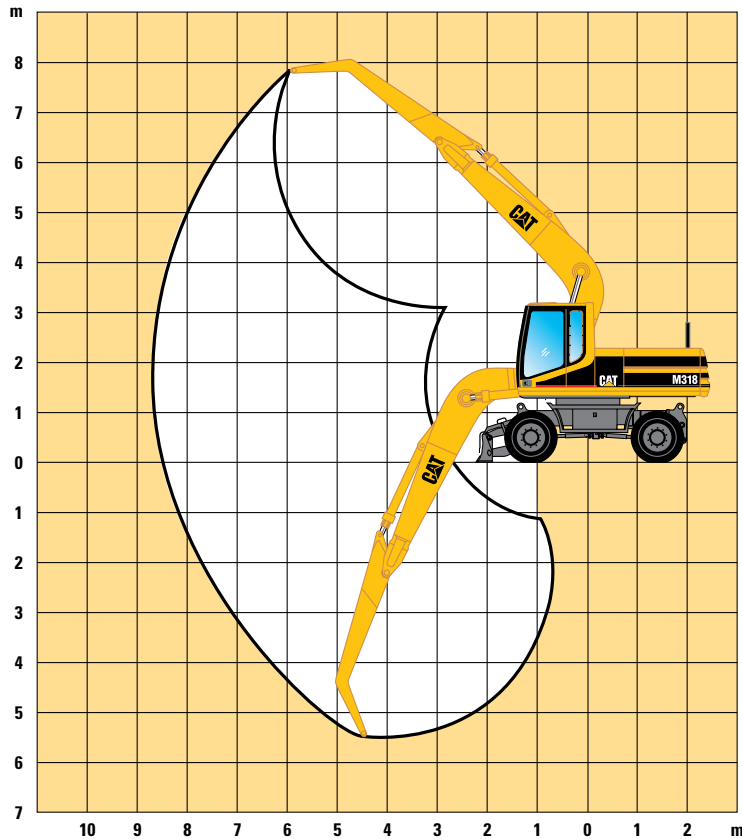

Lift capacities M318 One-piece-boom

With 400 kg additional counterweight and “heavy lift” arrangement. All weights are in metric tons.

**Height	Undercarriage configuration	3.0 m		4.5 m		6.0 m		7.5 m		9.0 m		m
4.50 m	All stabilizers up					*4.7	3.3	3.7	2.3			
	All stabilizers down					*4.7	*4.7	*4.2	*4.2			
3.00 m	All stabilizers up	*10.2	8.1	*6.7	4.6	5.0	3.1	3.6	2.3			
	All stabilizers down	*10.2	*10.2	*6.7	*6.7	*5.5	*5.5	*4.9	4.2		*2.9	1.9
1.50 m	All stabilizers up	*5.6	*5.6	7.3	4.2	4.8	2.9	3.5	2.2		2.9	1.8
	All stabilizers down	*5.6	*5.6	*8.5	*8.5	*6.3	5.7	*5.3	4.1		*3.0	*3.0
0.00 m	All stabilizers up			7.1	4.0	4.7	2.8	3.5	2.1		3.0	1.8
	All stabilizers down			*9.5	8.5	*6.9	5.5	*5.6	4.1		*3.4	*3.4
-1.50 m	All stabilizers up			6.9	3.9	4.6	2.7	3.4	2.1		3.2	2.0
	All stabilizers down			*9.8	8.4	*7.2	5.5	*5.6	4.0		*4.0	3.8
-3.00 m	All stabilizers up	*13.0	6.9	6.9	3.9	4.6	2.7				3.8	2.3
	All stabilizers down	*13.0	*13.0	*9.2	8.4	*6.8	5.4				*5.3	4.4
-4.50 m	All stabilizers up	*10.8	7.1	7.1	4.0							
	All stabilizers down	*10.8	*10.8	*7.5	*7.5							



Load Radius Over Front



Load Radius Over Side

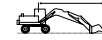

Load at Maximum Reach

* Limited by hydraulic rather than tipping load

** Height of stick pin

The above loads are in compliance with hydraulic excavator lift capacity ratings standard ISO 10567, they do not exceed 87% of hydraulic lifting capacity or 75% of tipping capacity. Weight of all lifting accessories must be deducted from the above lift capacities

M318 MH and M320 MH Material Handler M312, M315 and M318 Industrial Arrangement

HEHH2328 (0398) hr

Featured photos of machines may not always include standard equipment.
See your Caterpillar dealer for available options.
Materials and specifications are subject to change without notice.

© 1998 Caterpillar

CATERPILLAR[®]