

AP-900B

Rubber Tire
Asphalt Paver



Operating weight:

with Extend-A-Mat B Screed	17 900 kg	39,350 lb
with Pavemaster B Screed	16 300 kg	35,800 lb
Hopper Capacity	6,1 cu m	215 cu ft
Standard Paving Width	3,05 m	10 ft
Maximum Paving Range:		
with Extend-A-Mat B Screed	2,44 - 7,37 m	8 - 24 ft 2 in
with Pavemaster B Screed	2,44 - 9,14 m	8 - 30 ft

Caterpillar® Diesel Engine

Model 3116T is a high-tech six cylinder diesel engine designed to provide quiet performance, high reliability, easy servicing and excellent fuel economy.

Turbocharged for top performance and efficiency especially at high altitudes.

Transverse-mounted engine provides better cooling performance and greater accessibility for service.

Meets EPA/CARB emissions engine regulations.

Low sound emission complies with major regulatory rules according to Caterpillar sound pad test results.

Heavy duty unit-type fuel injection and low pressure fuel lines minimize opportunity for fuel leaks.

Intake manifold heater preheats incoming air for quick cold-weather starting.

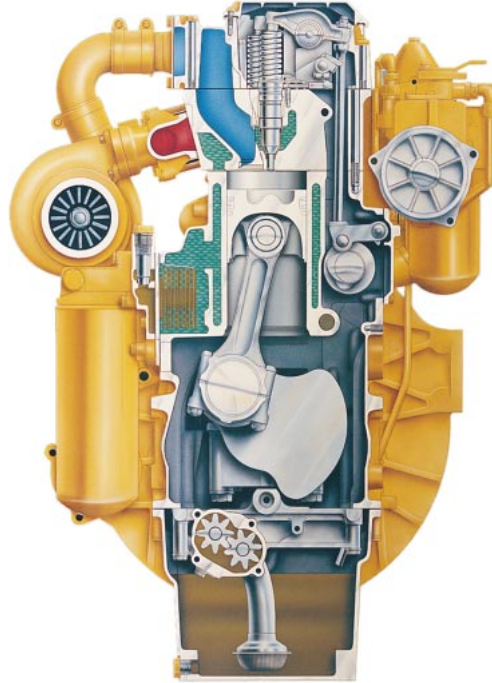

Hydrostatic Drive System

Efficient hydraulic drive system eliminates chains and other mechanical linkages between diesel engine and final drive components.

Fully hydrostatic transmission provides efficient, low-maintenance operation.

Anti-slip/balance propel system assures either wheel will continue to drive even if the other wheel is slipping.

Separate propel circuit for each drive wheel provides positive traction.

Infinite speed selection within the pave and travel speed ranges.

Optional front wheel assist enhances rimpull on soft bases.

Dual-Displacement Propel Motors

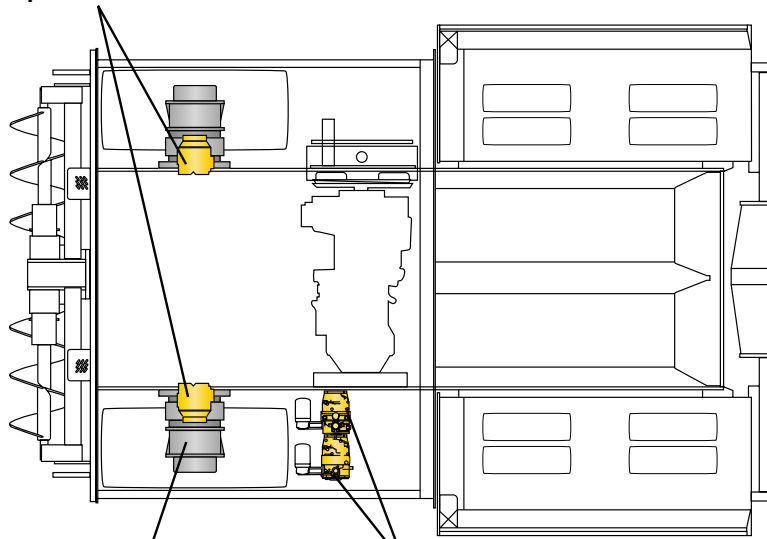

Single-Speed Planetary Drive

Variable-Displacement Propel Pumps

Operator's Station

Single operator's station designed for comfort and optimum efficiency.

Single operator's station slides from side to side and includes fully equipped instrument console and steering wheel with lockable cover.

Dual-slide feature allows the seat to be moved from side to side and front to back on the pedestal frame, enhancing visibility.

Operator's seat pivots 152 mm (6") to the left or right to further enhance operator visibility.

Low-mounted engine provides unobstructed forward visibility.

Electrical wiring protected by an articulated vinyl enclosure.

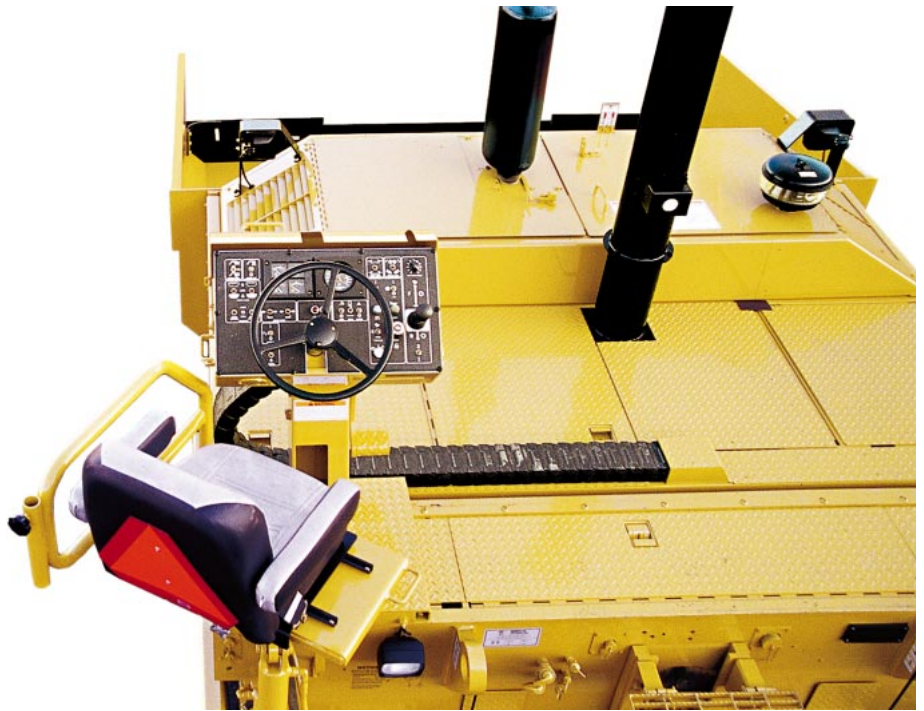

Control Console

Full instrumentation package keeps operator informed of status of all major systems.

International symbols and functional word descriptions are shown for all controls.

Gauges are analog type for quick interpretation.

Warning lights illuminate and horn alerts operator to:

- High hydraulic oil temperature;
- Low hydraulic oil level;
- Low engine oil pressure; or
- High engine coolant temperature.

Speed control allows the operator to dial a maximum paving speed. Once set, the paver returns to the preset speed when propel lever is in full forward position.



Material Handling System

Precise mix delivery through the most advanced material handling system.

Automatic fully proportional feeder/auger system provides superior material control.

Left and right feeder/auger units are controlled independently of each other.

Wear items are alloy steel for long wear life.

Cast Ni-hard auger flights are 406 mm (16") diameter and provide long service life.

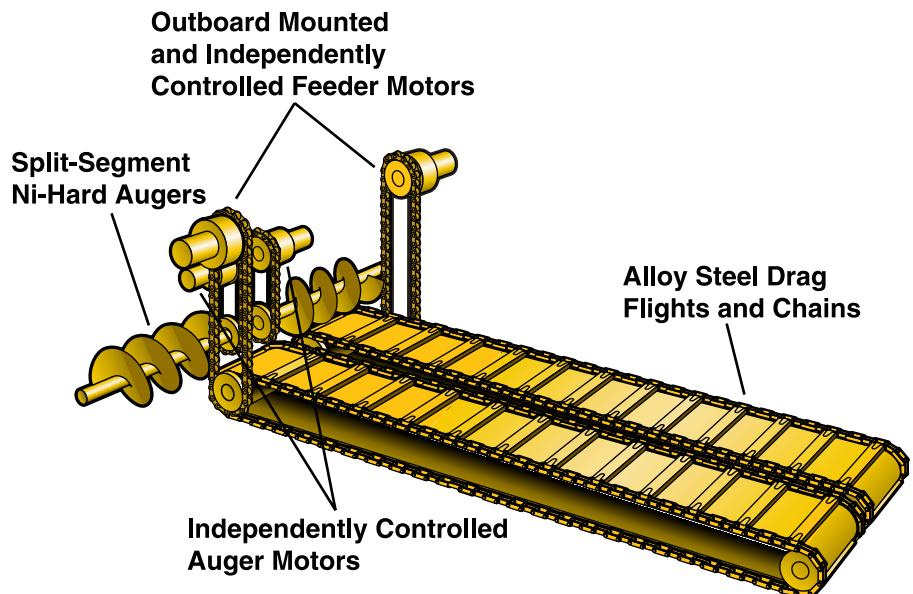

Outboard Feeder Drives

Increased live tunnel area provides easy servicing.

Feeders have outboard mounted motors, reducers and feeder drive chains to maximize the live feeder tunnel area.

Help eliminate center-line streaks.

Help eliminate segregation created by inboard feeder drives.

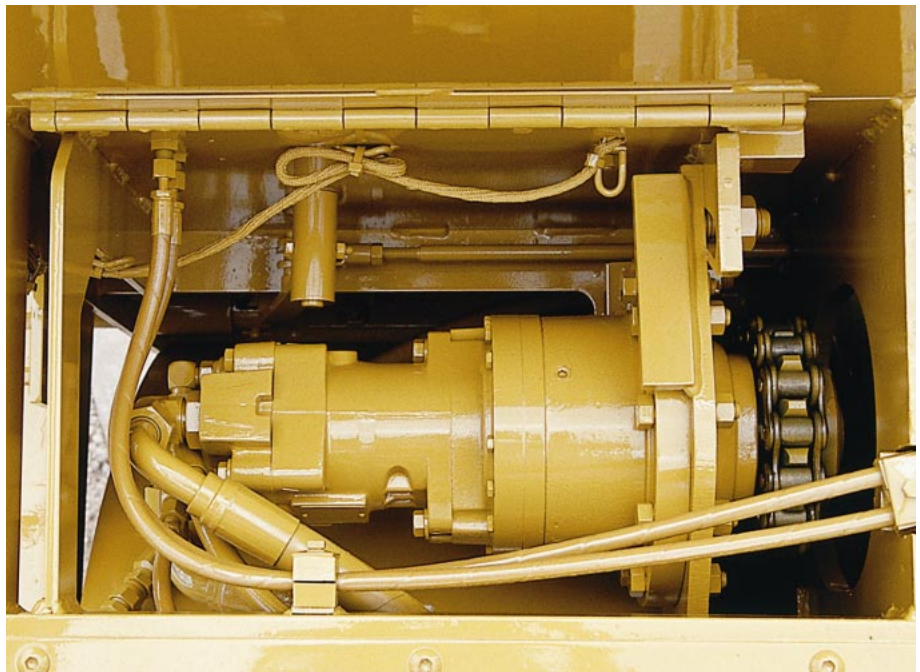

Adjustable Height Auger Assembly

Promotes mat consistency and minimizes segregation.

Auger assembly can be hydraulically adjusted 142 mm (5.6").

When working with larger stone mixes, segregation can often be eliminated or minimized by raising the augers to allow mix to flow unrestricted under the auger assembly.

Ability to raise the auger assembly simplifies loading and unloading from a transport vehicle.

Dual auger cylinders enhance quality when working with large stone mixes.

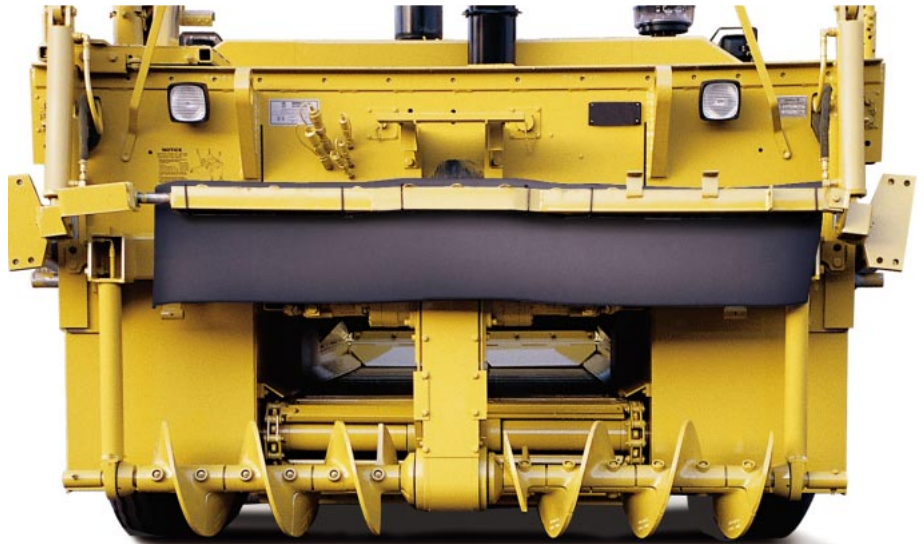

Serviceability

Simplified service means more paving and less maintenance time.

Large swing-open doors and panels provide access to all service areas.

Transverse engine mounting provides ground-level access to hydraulic pumps and engine cooling system.

Low-mounted engine provides easy, ground-level access for servicing.

Easy-identification wire coding system simplifies troubleshooting electrical systems.

Lubrication fittings are clustered for quick service.



Extend-A-Mat 10-20B Screed

Variable width, power extending screed increases productivity and lowers operating costs.

Model 10-20B paves from 3,05 m to 5,94 m (10' to 19' 6"). With cutoff shoes and extensions, range is 2,44 m to 7,37 m (8' to 24' 2").

Mat thickness and crown are accurately controlled at any paving width.

Extenders slope from 14 percent below to 2 percent above horizontal and can be adjusted on the go.

Four fuel oil burners with electric ignition provide even screed plate heating. Insulated combustion chamber provides even heat distribution.

Triangular configuration of extender tubes and frame member improves torsional resistance.



Extend-A-Mat B shown with AP-1050B Asphalt Paver.

Pavemaster 10B Screed

Heavy-duty conventional fixed-width screed provides simple economical operation.

Model 10B has a fixed paving width of 3,05 m (10'). With cutoff shoes and extensions, paving range is from 2,44 m to 9,14 m (8' to 30').

Two fuel oil burners with electric ignition provide even screed plate heating. Insulated combustion chambers provide even heat distribution.



Pavemaster 10B shown with AP-1050B Asphalt Paver.

Customer Support

Cat dealer services help you operate longer with lower costs.



Your Cat Dealer offers a wide range of services that can be set up under a customer support agreement when purchasing equipment. The dealer will help customers choose a plan that can cover everything from machine and attachment selection to replacement, to help get the best return on the machine investment.

Selection. Make detailed comparisons of the machines under consideration before buying. How long do components last? What is the cost of preventive maintenance? What is the true cost of lost production? Cat Dealers can give precise answers to these questions.

Operation. Improving operating techniques can boost one's profits. Cat Dealers have training videotapes, literature and other ideas to help increase productivity.

Purchase. Look past initial price. Consider the financing options available as well as day-to-day operating costs. This is also the time to look at dealer services that can be included in the cost of the machine to yield lower equipment owning and operating costs over the long run.

Maintenance. More and more equipment buyers are planning for effective maintenance before buying equipment. Choose from the dealer's wide range of maintenance services at the time of purchase. Repair option programs guarantee the cost of repairs up front. Diagnostic programs such as S•O•S oil analysis and Technical Analysis help avoid unscheduled repairs.

Product support. Nearly all parts are available at the Cat Dealer parts counter. Cat Dealers utilize a worldwide computer network to find in-stock parts to minimize machine downtime. Save money with remanufactured parts and receive the same warranty and reliability as new products at cost savings of 40 to 70 percent.

Replacement. Repair, rebuild or replace? Cat Dealers can help evaluate the cost involved so the right choice is made.

Engine

Cat 3116T turbocharged, four stroke/cycle six cylinder diesel engine. Meets EPA and CARB low emissions engine regulations.

Ratings at 2,200 RPM	kW	hp
Gross power	114	153

Ratings of Caterpillar machine engines are based on standard air conditions of 25°C (77°F) and 99 kPa (29.32") Hg dry barometer. Power is based on using 35° API gravity fuel having an LHV of 42,780 kJ/kg (18,390 Btu/lb) when used at 30°C (86°F) [ref. a fuel density of 838.9 g/L (7.001 lb/U.S. gal)]. Net power advertised is the power available at the flywheel when the engine is equipped with fan, air cleaner, muffler and alternator.

The following ratings apply at 2,200 RPM when tested under the specified standard conditions for the specified standard:

Net Power	kW	hp
EEC 80/1269	104	139
ISO 9249	104	139

Dimensions

Bore	105 mm	4.12"
Stroke	127 mm	5.0"
Displacement	6,6 L	403 cu. in

Drive System

The drive utilizes a totally hydrostatic propel system. Engine mounted variable-displacement pumps drive two-speed variable-displacement wheel motors mounted directly to high-torque, single-speed final drives. Planetary drive boxes have multi-disc parking brake.

Forward speed ranges

Pave*	0-122 mpm	0-400 fpm
Travel	0-16 kmph	0-10 mph

Speeds may vary slightly due to type of tires used.

* If equipped with optional front wheel assist, maximum paving speed is 69 mpm (225 fpm).

Hydraulic Oil Filtration

Propel pumps and motors have 10-micron filters and the feeder pumps and motors have 10-micron filtration. Both have remote filter condition gauges. Vibrator pump has a 125-micron suction strainer at the inlet. The auxiliary pump has 125-micron strainer on the inlet. Return oil has a 7-micron filter with indicator.

Steering

Steering is full power via an automotive-type steering wheel at the operator's station. Heavy duty tandem articulated dual bogies on each side are mechanically connected and guided by a single modulated hydraulic cylinder. Bogies are 406 mm (16") wide by 559 mm (22") diameter solid rubber tires.

Inside Turning Radius
2,9 m (9' 6")

Brakes

Primary braking system: Hydrostatic transmission dynamic braking.

Parking brake system: Spring applied, hydraulically released parking brake, which is actuated by a switch on the console.

Suspension

Four front wheels, two per side, are mounted in tandem on bogie axles, equalizing ground pressure.

Drive Tires (sand rib)
18:00 x 25

Steering Tires (solid rubber)
406 mm x 559 mm (16" x 22")

Operator's Station

A single operator's station slides from one side of paver to the other. The operator's seat has a dual-slide feature that allows it to be slid from side to side and front to back on the pedestal frame. The pedestal also swivels to the left or right 152 mm (6") to further improve operator visibility. Deluxe seat with arm rests has heat-reflective cover. Station has a complete instrument console and an adjustable, pivoting seat with seat belt. All console wiring is protected by an articulated vinyl enclosure.

Operator's Console

Control console with lockable vandal cover includes: steering wheel, hopper raise/lower switch; left and right feeder auto/off/man switch; horn button; propel forward/reverse control lever; pave/travel speed range selection switches; maximum speed control; engine ignition switch; parking brake switch; feeder gate control switches; screed vibrator switch on/off; screed lift switch up/down; and extender switches in/out.

Operator's console and station also includes: foot brake pedal; engine throttle fast/slow; auger raise/lower switch; and hydraulic limited slip lock on/off switch. the following are options: truck hitch control in/out; front wheel assist on/off switch; work lights on/off; hazard light on/off switch; and screed counterbalance system.

Instrumentation

Operator's console includes: system warning light for high hydraulic oil temperature, low hydraulic oil level, low engine oil pressure, and high water temperature; battery charging light; engine temperature gauge; fuel level gauge; oil pressure gauge; hydraulic oil temperature gauge, hourmeter and engine tachometer.

Electrical System

The 24-volt electrical system utilizes two 12-volt batteries and a 24-volt, 52-amp alternator. The wiring is color coded and number impregnated for easy servicing. All wiring is protected by vinyl coated nylon braiding for greater durability.

Ventilation System

The Ventilation System helps remove asphalt vapors from the auger chamber area. The system consists of a hydraulically driven exhaust fan, ducts and exhaust stack to vent asphalt vapors away from the operator and screed areas. Design provides unobstructed visibility to augers.

Frame

H-section mainframe construction with integral tunnel cover. Frame fabricated from heavy gauge steel plate. Tunnel cover is 9,5 mm (0.375") thick, and the feeder base is 9,5 mm (0.375") thick.

Feeders and Augers

Variable proportional hydrostatically driven dual feeders and augers operate independently of forward speed. Right and left side augers/feeders operate independently of each other. Feeder drive and drive chains are located outside the mainframe for easy accessibility.

Feeder flights are constructed of heavy-duty bushed roller chain with forged steel flight bars sliding over replaceable, abrasion resistant drag pans with 360-440 Brinell hardness.

Long life auger system consists of segmented, 406 mm (16") diameter, cast Ni-Hard steel hemi-screw augers. Auger and hanger bearings have built-in steel shields for greater protection. Augers are driven independently by two motors. Each auger is controlled by an adjustable material flow switch. Manual override is provided. Auger height is hydraulically adjustable 142 mm (5.6").

Hopper

Power hopper dumping, controlled from control console. Heavy-duty flashing prevents material spillage.

Capacity

6,1 cu m (215 cu ft)

Truck Entry Width

3200 mm (10' 6")

Truck Dump Height

623 mm (24.5")

Service Refill Capacities

	Liters	Gallons
Fuel Tank	265	70
Hydraulic Oil Tank	189	50
Cooling System	37	9.8

Weights (approximate)

Tractor

14 445 kg (31,850 lb)

With Extend-A-Mat 10-20B
and truck hitch or push roller

17 900 kg (39,350 lb)

With Pavemaster 10B

and truck hitch or push roller

16 300 kg (35,800 lb)

Dimensions

	Extend-A-Mat B Screed	Pavemaster B Screed
A Length with push roller with truck hitch	6783 mm (22' 3") 7264 mm (23' 10")	6285 mm (20' 7") 6756 mm (22' 2")
B Operating width	3327 mm (10' 11")	3327 mm (10' 11")
C Overall height	3378 mm (11' 1")	3378 mm (11' 1")
D Transport width (hoppers raised) with end gates Transport width (hoppers raised) without end gates	3327 mm (10' 11") 3048 mm (10')	3327 mm (10' 11") 3048 mm (10')
E Transport height (muffler removed)	2769 mm (9' 1")	2769 mm (9' 1")
F Wheel base	2540 mm (100")	2540 mm (100")
G Front wheel gauge	2491 mm (98")	2491 mm (98")
H Rear wheel gauge	2284 mm (90")	2284 mm (90")
Inside turning radius	2,9 m (9' 6")	2,9 m (9' 6")

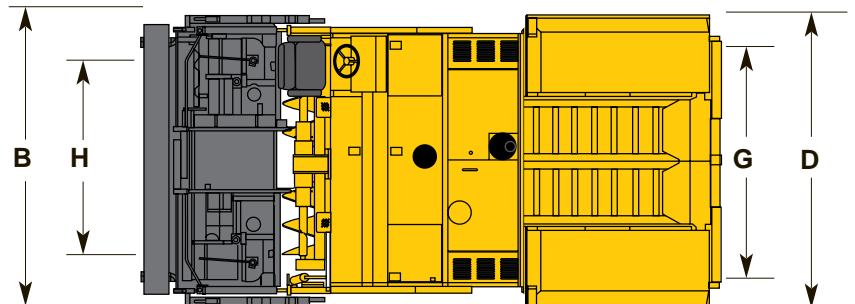
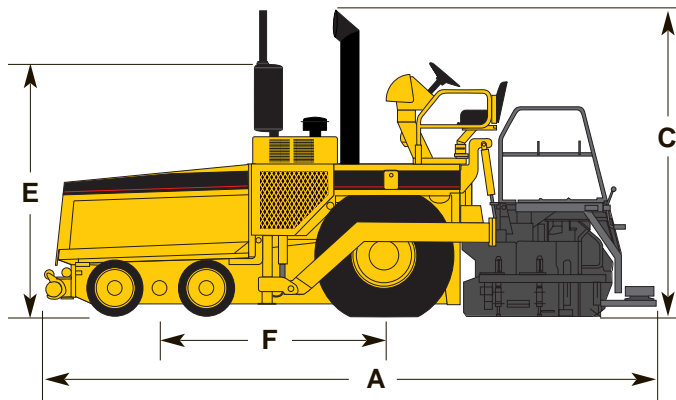

Optional Equipment

Tractor

Front Wheel Assist adds hydrostatic propel power to two of the four front steering wheels. The system increases rimpull power, providing enhanced traction.

Aggressive Tread Drive Tires are available for applications requiring greater tractive effort. XGC 16:00 x 25 radial tires have a more aggressive tread than the standard sand rib tires.

Oscillating Push Rollers provide a contact point between paver and truck to center load and assist steering.

Truck Hitch provides positive locking between paver and truck when unloading trucks. Hydraulically actuated from the operator's console.

Lighting Package consists of four variable position sealed beam flood lights, two mounted forward and two mounted to the rear, illuminate work area.

Hazard Light consists of rotating amber beacon and mount, increasing visibility during paving or roading of paver.

6 kW or 8 kW Generators are hydraulically driven through a load-sensing, pressure-compensating pump. The hydraulically driven pump provides quiet operation, and the load-sensing pump and a control manifold maintain constant electrical frequency at both high and low idle. All outlets are GFCI protected.

Controls and References

Automatic Grade and Slope Controls provide full proportional control for both longitudinal grade and transverse slope.

Basic package includes two screed mounted control units, slope sensor and mounting hardware. Option includes wand or sonic grade sensors.

Auger/Feeder Control Sensors monitor material level in front of screed and proportionally control material feed to maintain desired level of mix ahead of screed. This system fits paddle or sonic sensors.

Rigid Ski is a triangular truss rigid ski that rides directly on the pavement. Grade sensor can reference directly off ski or a stringline mounted to the ski. Available in 9,1 m (30') and 12,2 m (40') lengths.

Outboard Leveler is a traveling multi-foot outboard mounted grade reference that provides a mean average on the surface on which it is operating. Available in 9,1 m (30') and 12,2 m (40') lengths.

Inboard Leveler is a traveling stringline with many of the features of the Outboard Leveler. Mounts ahead of the screed extensions and inboard of the screed end plate. Used when outboard referencing is not practical.

Mobile Stringline consists of a two-section arrangement of beams and sleds that mount outboard of the screed. Package includes beams, sleds, stringline, pivot pins, brackets and attaching hardware.

Fore 'N Aft Leveler is a traveling stringline that mounts inboard of the screed end plate and bridges the screed extensions to reference both ahead and behind the screed.

Screeds

The AP-900B is offered with a choice of two screeds: the Extend-A-Mat 10-20B Screed and the Pavemaster 10B Screed. Paving packages are available for both screeds in widths to match the paving capability of the tractor.

Extend-A-Mat B Screed Options

Automatic Burner System thermostatically controls the screed plate heating system, helping maintain a consistent temperature.

Power Controls for Slope, Crown and Height include electric motor-driven gearboxes that provide fingertip operation of main screed crown, extender slope and extender height adjustments.

Screed Extensions are available in 305 mm (1') and 711 mm (2' 4") widths. Heat is by convection from the main screed. Vibration is provided on the 711 mm (2' 4") extension.

Cutoff Shoe Package consists of one 305 mm (1') and one 610 mm (2') cutoff shoe to reduce paving width in 76 mm (3") increments.

Bevel End Plates available to bevel mat edges for 38 mm (1.5"), 51 mm (2"), 64 mm (2.5"), and 76 mm (3") pavement thickness.

Berm Extensions available in right or left configurations. Lengths offered: 357 mm (14"), 508 mm (20"), and 660 mm (26"). All have 457 mm (18") screed plates. Slope is adjustable from 0 to 127 mm (5") high at outside edge. Wiring harness for extender control box supplied.

Pavemaster B Screed Options

Power Crown includes an electric motor-driven gearbox that provides fingertip control of main screed crown.

Screed Extensions available in 152 mm (6"), 305 mm (1'), 610 mm (2') widths with crowning, and 914 mm (3') widths. Heat and vibration available on 610 mm (2') and 914 mm (3') extensions.

QEHQ9738 (3-00)

© 2000 Caterpillar

Caterpillar follows a policy of continual product improvement.
For this reason, some material and specifications could change without notice.

CATERPILLAR[®]