

BG-260C

Rubber Tire
Asphalt Paver

CAT[®]



Cat[®] BG-260C

Operating weight:

with Extend-A-Mat B Screed	18 940 kg	41,750 lb
with Pavemaster B Screed	17 330 kg	38,200 lb

Hopper Capacity	6,1 cu m	215 cu ft
-----------------	----------	-----------

Standard Paving Width	3,05 m	10 ft
-----------------------	--------	-------

Maximum Paving Range:

with Extend-A-Mat B Screed	2,44 - 7,37 m	8 - 24 ft 2 in
with Pavemaster B Screed	2,44 - 9,14 m	8 - 30 ft

Caterpillar® Diesel Engine

Model 3116TA is a high-tech six cylinder diesel engine designed to provide quiet performance, high reliability, easy servicing and excellent fuel economy.

Turbocharged for top performance and efficiency especially at high altitudes.

Transverse-mounted engine provides better cooling performance and greater accessibility for service.

Meets EPA/CARB low emissions engine regulations.

Low sound emission complies with major regulatory rules according to Caterpillar sound pad test results.

Heavy duty unit-type fuel injection and low pressure fuel lines minimize opportunity for fuel leaks.

Intake manifold heater preheats incoming air for quick cold-weather starting.

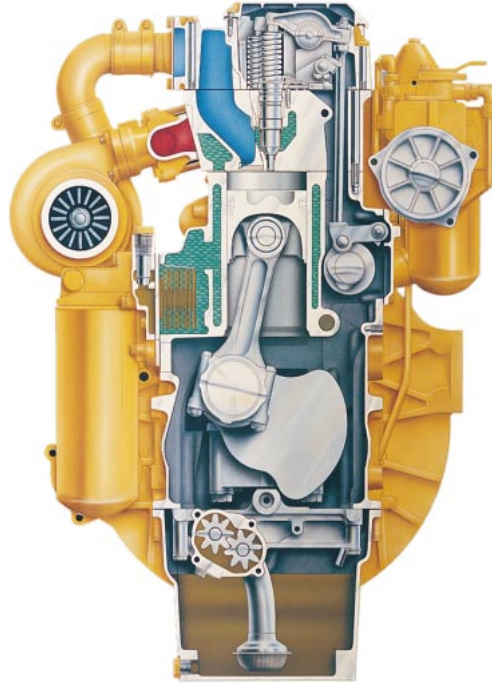

Hydrostatic Drive System

Efficient hydraulic drive system eliminates chains and other mechanical linkages between diesel engine and final drive components.

Closed-loop hydrostatic propel system provides efficient, low-maintenance operation.

Speed control system maintains preset paving speeds throughout a job.

Propulsion controller provides accurate control of steering and propulsion systems.

Decel pedal provides foot control of propel speed freeing operator to control other paving functions.

Dual path steering system utilizes steering wheel for simplified operation.

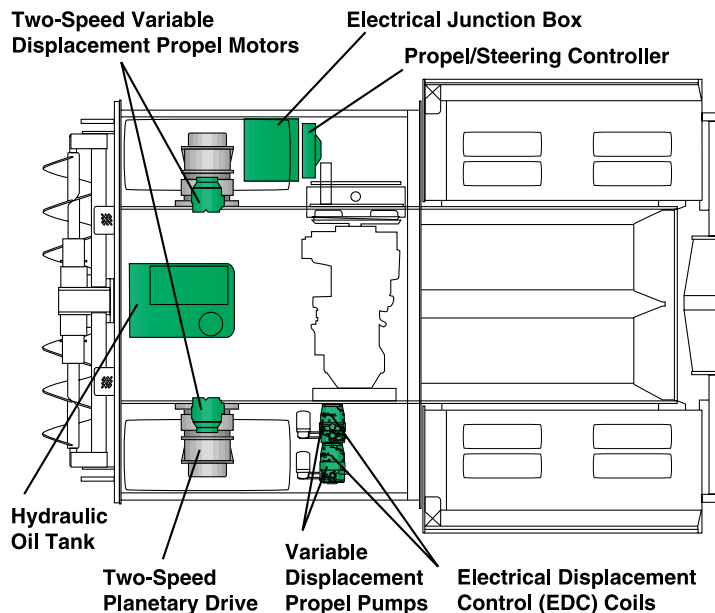

Operator's Station

Single operator's station designed for comfort and optimum efficiency.

Single operator's station slides from side to side and includes fully equipped instrument console and steering wheel with lockable cover.

Operator's seat pivots 152 mm (6") to the left or right to further improve operator visibility.

Low-mounted engine provides unobstructed forward visibility.



Control Console

Full instrumentation package keeps operator informed of all major systems status.

International symbols and functional word descriptions are shown for all controls.

Gauges are analog type for quick interpretation.

Warning lights illuminate and horn alert operator to:

- High hydraulic oil temperature;
- Low hydraulic oil level;
- Low engine oil pressure; or
- High engine coolant temperature.

Speed control allows the operator to dial a maximum paving speed. Once set, the paver returns to the preset speed when propel lever is in full forward position.

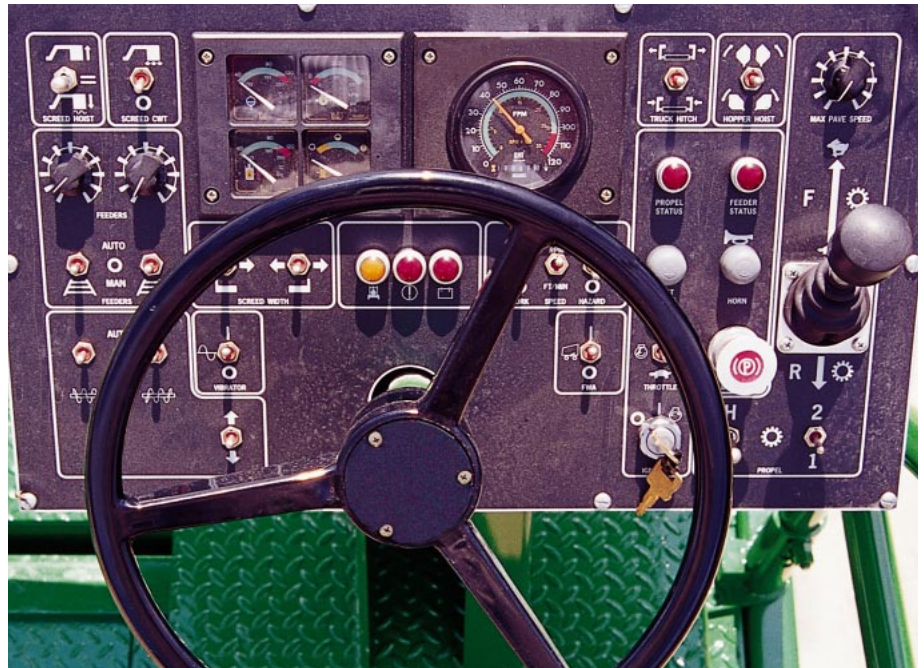

Exclusive Feeder/Auger Control System

Precise mix delivery through the most advanced material handling system.

Left and right feeders and left and right augers are all controlled independently, eliminating the need for feeder gates.

Once the feeder speeds are set, the ratio of feeder speed to the maximum auger speed is automatically maintained by the material handling controller, regardless of propel rate or paving widths.

To control mix delivery, the operator sets a speed rate for each feeder that will maintain the desired mix level in the left and right auger chambers.

Component wear is reduced because full feeders run at slower speeds.

Potential for mix segregation is minimized because head of material remains constant.

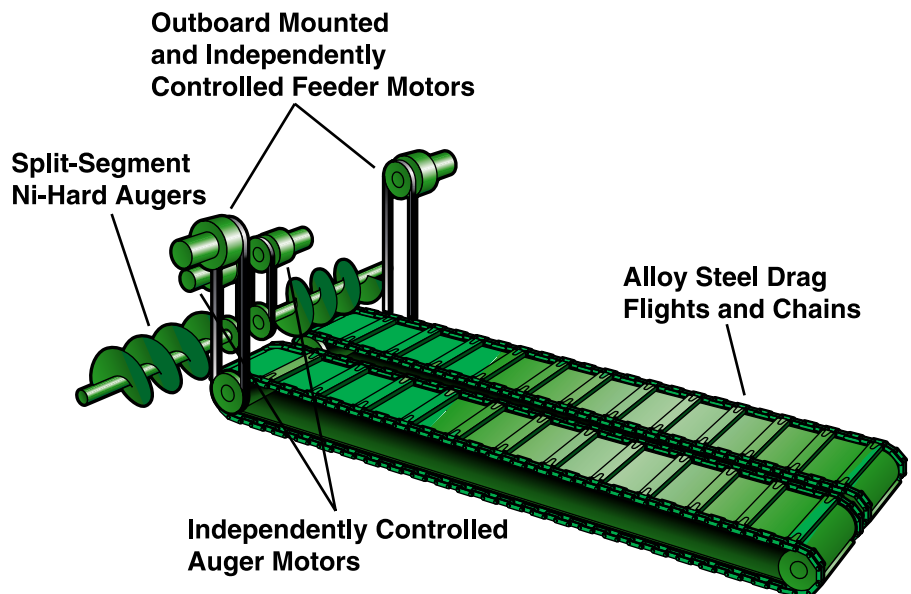

Gateless Feeders

Slower running feeders reduce wear and segregation.

Gateless feeders always run full of mix regardless of the speed required to fill the auger chamber.

When changes in feeder speed are needed, delivery of mix to the augers is immediate.

Drag pans are constructed with abrasion resistant, heat treated steel.

Feeder flight bars are forged steel and pinned to two strands of roller bushed chain.

Potential for segregation is reduced with slower running feeders, especially when working with large stone mixes.

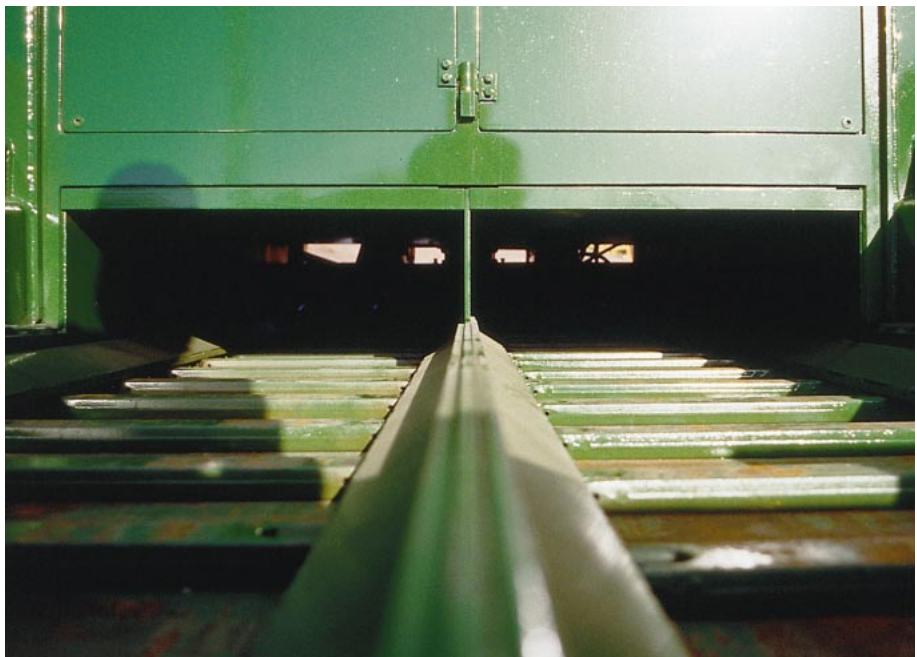

Feeder Design Improves Mix Flow

Tunnel construction helps minimize segregation.

Distance between the two feeders is significantly reduced because the auger drive assembly is not part of the tractor.

Narrow distance between feeders allows flow from both feeders to blend together easily as they discharge into the auger cavity. This design helps minimize segregation.

Since the auger case is not attached to the tractor, voids under the chain case are eliminated.

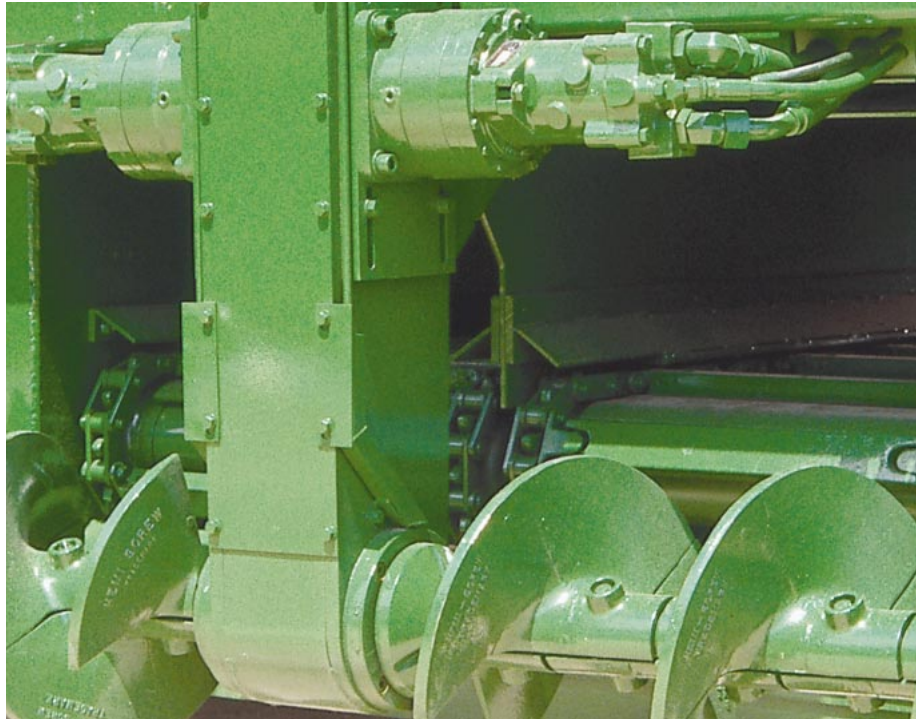

Outboard Feeder Drives

Increased live tunnel area provides easy servicing.

Feeders have outboard mounted motors, reducers and feeder drive chains to maximize the live feeder tunnel area.

Simplified service access through a hinged door on the operator's station.

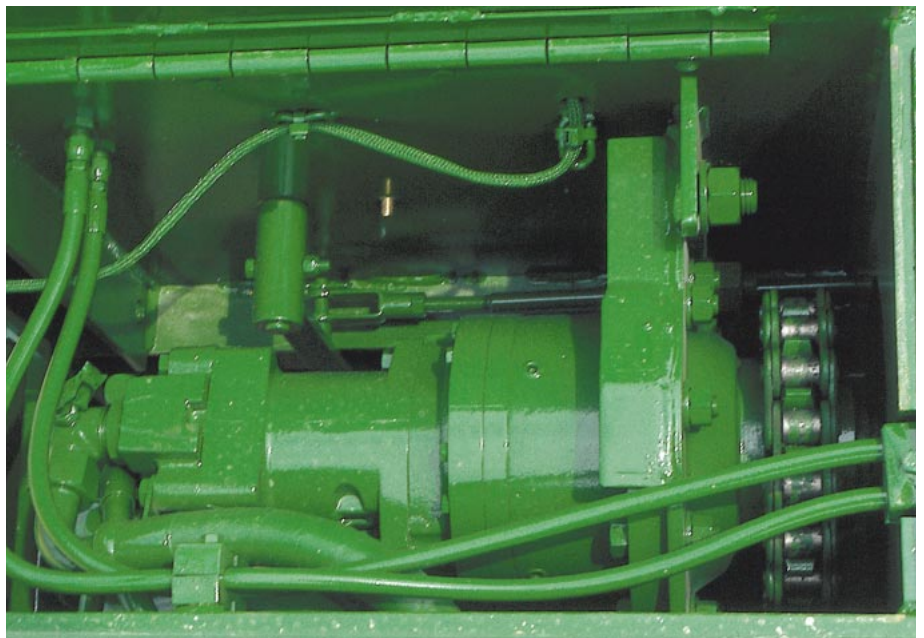

Adjustable Height Auger Assembly

Promotes mat consistency and minimizes segregation.

Auger assembly can be hydraulically adjusted 171 mm (6.75").

When working with larger stone mixes, segregation can often be eliminated or minimized by raising the augers to allow mix to flow unrestricted under the auger assembly.

Ability to raise the auger assembly simplifies loading and unloading from a transport vehicle.



Serviceability

Simplified service means more paving and less maintenance time.

Large swing-open doors and panels provide access to all service areas.

Transverse engine mounting provides ground-level access to hydraulic pumps and engine cooling system.

Color coded and numbered wiring system simplifies troubleshooting electrical systems.

Lubrication fittings are clustered for quick service.

Propulsion and material controllers provide diagnostic capability for trouble shooting hydraulic and electrical systems.



Extend-A-Mat B Screed - Model 10-20B

Variable width, power extending screed increases productivity and lowers operating costs.

Model 10-20B paves from 3,05 m to 5,94 m (10' to 19' 6"). With cutoff shoes and extensions, range is 2,44 m to 7,37 m (8' to 24' 2").

Mat thickness and crown are accurately controlled at any paving width.

Extenders slope from 14 percent below to 2 percent above horizontal and can be adjusted on the go.

Four fuel oil burners with electric ignition provide even screed plate heating. Insulated combustion chamber provides even heat distribution.

Triangular configuration of extender tubes and frame member improves torsional resistance.



Extend-A-Mat Screed shown with BG-2455C Asphalt Paver.

Pavemaster B Screed - Model 10B

Heavy-duty conventional fixed-width screed provides simple economical operation.

Model 10B has a fixed paving width of 3,05 m (10'). With cutoff shoes and extensions, paving range is from 2,44 m to 9,14 m (8' to 30').

Two fuel oil burners with electric ignition provide even screed plate heating. Insulated combustion chambers provide even heat distribution.

Optional hydraulic strike offs extend to 1,1 m (3' 6") on both sides of screed and have 152 mm (6") wide screed plates. Strike offs have on-the-go height and slope adjustment as standard features. They can be sloped down 8 degrees or 14 percent (no up slope).



Engine

Cat 3116TA turbocharged and aftercooled, four stroke/cycle six cylinder diesel engine. Meets EPA and CARB low emissions engine regulations.

Ratings at 2200 RPM	kW	Hp
Gross power	130	174
Net power	118	158

Ratings of Caterpillar machine engines are based on standard air conditions of 25°C (77°F) and 99 kPa (29.32") Hg dry barometer. Power is based on using 35° API gravity fuel having an LHV of 42,780 kJ/kg (18,390 Btu/lb) when used at 30°C (86°F) [ref. a fuel density of 838.9 g/L (7.001 lb/U.S. gal)]. Net power advertised is the power available at the flywheel when the engine is equipped with fan, air cleaner, muffler and alternator.

The following ratings apply at 2200 RPM when tested under the specified standard conditions for the specified standard:

Net Power	kW	Hp	Ps
Caterpillar	118	158	—
EEC 80/1269	118	158	—
ISO 9249	118	158	—
SAE J1349 (JAN)90	118	158	—
DIN 70020	—	—	164
ISO 3046/2	118	158	—

Dimensions

Bore	105 mm	4.12"
Stroke	127 mm	5.0"
Displacement	6.6 L	403 cu. in

Drive System

The drive is via two dual path hydrostatic pumps and variable displacement motors. Pumps are infinitely variable with electric dual controls for steering and speed. Motors have two displacement settings for four speed ranges.

Forward speed ranges		
Pave low	0-68,5 mpm	0-224 fpm
Pave high	0-114 mpm	0-374 fpm
Travel low	0-17 kmph	0-10.5 mph
Travel high	0-23,5 kmph	0-14.5 mph

Speeds may vary slightly due to type of tires used.

Hydraulic Oil Filtration

Propel pumps have 10-micron integral charge loop filtration and 7-micron reservoir return filtration. The material feed system (feeders/augers) has 5-micron integral charge loop filtration. Vibrator pump has 125-mesh suction strainer on the inlet. The auxiliary pump has a 100-mesh suction strainer on the inlet.

Suspension

Four front wheels, two per side, are mounted in tandem on bogey axles, equalizing ground pressure.

Drive Tires (sand rib, hydroflated)
18:00 x 25

Steering Tires (solid rubber)
406 mm x 559 mm (16" x 22")

Steering

Steering is full power via an automotive-type steering wheel at the operator's station. Electric-over-hydraulic dual path differential steering assures precise machine control. Steering commands are independent of propel speed. Inside turning radius is 2,9 m (9' 6").

The steer assist feature improves maneuverability and enhances component life by slowing down the drive speed on one side of the propel system and speeding up the other according to steering commands.

Brakes

Service brake system: Closed-loop hydrostatic system provides dynamic braking. Parking brake system: Spring-applied/hydraulically released brake on wheel drives. Parking brake actuated by hand control at the operator's station or automatically when engine is shut down and whenever power switch is in off mode. Brake systems meet SAE recommended practice J2118 Feb94.

A brake interlock system helps prevent driving through the secondary brake.

Operator's Station

A single operator's station slides from one side of paver to the other. Operator's seat swivels 152 mm (6") to the left or right to further improve operator visibility. Deluxe seat with arm rests has heat-reflective cover. Station has a complete instrument console and an adjustable seat with seat belt. All console wiring is protected by an articulated vinyl enclosure.

Operator's Console

The single lockable operator's console has: steering wheel; decel pedal; engine throttle fast/slow switch; auger raise/lower switch; hopper raise/lower switch; left and right feeder auto/off/man switch; left and right feeder/auger ratio control; horn button; propel forward/reverse lever; maximum speed control dial; engine ignition switch; parking brake switch; heat start; screed vibrator on/off switch; screed lift up/down switch; extender in/out switch; screed counterbalance on/off switch.

Fumes Evacuation System

Fumes Evacuation System helps remove asphalt fumes from the auger chamber area. The system consists of shrouds in the auger chamber area, hydraulic-driven exhaust fan, ducts and exhaust stack to vent asphalt fumes away from the operator and screed areas.

Instrumentation

Gauges are analog-type for easy reading and quick interpretation. Instrumentation on the operator's console includes: Tachometer/foot-per-minute meter with hourmeter; hydraulic oil filter condition indicator light; system warning lights for high hydraulic oil temperature, low hydraulic oil level, low engine oil pressure, and high coolant temperature; battery charging light; engine temperature gauge; fuel level gauge; engine oil pressure gauge; hydraulic oil temperature gauge; propel system status light; and feeder system status light.

The operator is alerted by warning lights and a warning horn whenever the following conditions exist: high hydraulic oil temperature; low hydraulic oil level; low engine oil pressure; or high coolant temperature.

Electrical System

The 24-volt electrical system utilizes two 12-volt batteries and a 52-amp alternator. The electrical system provides 950 cold-cranking amps at -18° C (0° F). The wiring is color coded and numbered for easy servicing. All wiring is protected by vinyl coated nylon braiding for greater durability. All circuits tie to a main junction box with circuit breakers that can be reset.

Frame

H-section mainframe construction with integral tunnel cover. Frame fabricated from heavy gauge steel plate. Tunnel cover is 9,5 mm (0.375") thick, the feeder base is 15,8 mm (0.625") thick and the side plates are 19 mm (0.75") thick.

Feeders and Augers

Dual feeders and augers are controlled independently through variable speed drives. A material handling controller provides ratio control of augers and feeders. Paddle sensors control the feeders/augers to provide the exact volume of material required. Ratio adjustment eliminates the need for feeder gates. The system allows feeders to run full at lower speeds. Reduced component wear, lower horsepower required and less opportunity for segregation can be expected.

Right and left feeder/auger operate independently of each other. Feeder drive and drive chains are located outside the mainframe for easy accessibility.

Feeder flights are constructed of heavy-duty bushed roller chain with forged steel flight bars sliding over replaceable, abrasion resistant drag pans with 360-440 Brinell hardness.

Long-life auger system consists of segmented, 406 mm (16") diameter, cast Ni-Hard steel hemi-screw augers. Auger and hanger bearings have built-in steel shields for greater protection. Bearing-lube points are remote mounted for accessibility.

Hopper

Power hopper dumping, controlled from control console. Heavy-duty flashing prevents material spillage.

Capacity
6,1 cu m (215 cu ft)
Truck Entry Width
3182 mm (10' 5")

Service Refill Capacities

	Liters	Gallons
Fuel Tank	265	70
Hydraulic Oil Tank	189	50
Cooling System	37	9.78

Weights (approximate)

With Extend-A-Mat 10-20B Screed	18 940 kg (41,750 lb)
With Pavemaster 10B Screed	17 330 kg (38,200 lb)

Dimensions

	Extend-A-Mat B Screed	Pavemaster B Screed
A Length with push roller with truck hitch	6783 mm (22' 3") 7264 mm (23' 10")	6285 mm (20' 7") 6756 mm (22' 2")
B Operating width	3327 mm (10' 11")	3327 mm (10' 11")
C Overall height	3378 mm (11' 1")	3378 mm (11' 1")
D Transport width (hoppers raised) with end gates	3327 mm (10' 11")	3327 mm (10' 11")
Transport width (hoppers raised) without end gates	3048 mm (10')	3048 mm (10')
E Transport height (muffler removed)	2769 mm (9' 1")	2769 mm (9' 1")
F Wheel base	2540 mm (100")	2540 mm (100")
G Front wheel gauge	2491 mm (98")	2491 mm (98")
H Rear wheel gauge	2284 mm (90")	2284 mm (90")
Inside turning radius	2,9 m (9' 6")	2,9 m (9' 6")

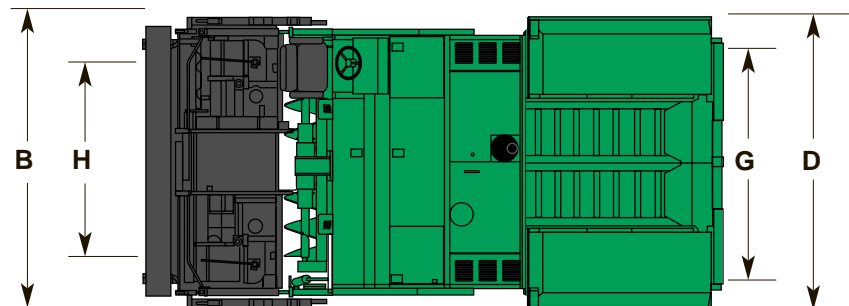
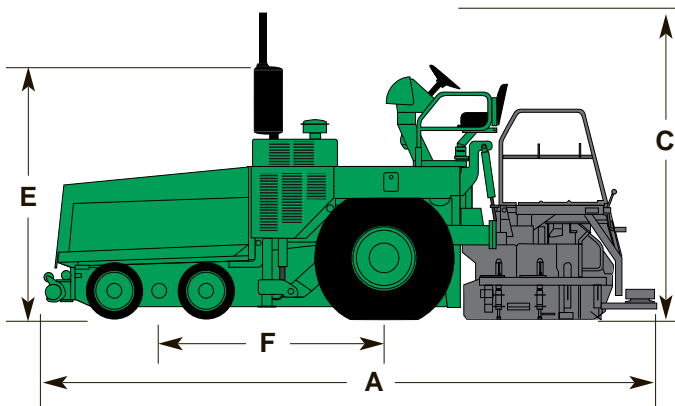

Optional Equipment

Tractor

Front Wheel Assist adds hydrostatic propel power to two of the four front steering wheels. The system increases rimpull power 20 percent for better traction.

Aggressive Tread Drive Tires are available for applications requiring greater tractive effort. The BG-260C can be equipped with XVC radial tires that have a more aggressive tread than the standard sand rib tires.

Oscillating Push Rollers provide contact point between paver and truck to center load and assist steering.

Truck Hitch provides positive locking between paver and truck when unloading trucks. Hydraulically actuated from the operator's console.

Lighting Package consists of four variable position sealed beam flood lights, two mounted forward and two mounted to the rear, illuminate work area.

Hazard Light consists of rotating amber beacon and mount, increasing visibility during paving or roading of paver.

Controls and References

Automatic Grade and Slope Controls provide full proportional control for both longitudinal grade and transverse slope.

Basic package includes two screed mounted control units, slope sensor and mounting hardware. Option includes wand or sonic grade sensors.

Auger/Feeder Control Sensors monitor material level in front of screed and proportionally control material feed to maintain desired level of mix ahead of screed. This system fits paddle or sonic sensors.

Rigid Ski is a triangular truss rigid ski that rides directly on the pavement. Grade sensor can reference directly off ski or a stringline mounted to the ski. Available in 9,1 m (30') and 12,2 m (40') lengths.

Outboard Leveler is a traveling multi-foot outboard mounted grade reference that provides a mean average on the surface on which it is operating. Available in 9,1 m (30') and 12,2 m (40') lengths.

Inboard Leveler is a traveling stringline with many of the features of the Outboard Leveler. Mounts ahead of the screed extensions and inboard of the screed end plate. Used when outboard referencing is not practical.

Mobile Stringline consists of a two-section arrangement of beams and sleds that mount outboard of the screed. Package includes beams, sleds, stringline, pivot pins, brackets and attaching hardware.

Fore 'N Aft Leveler is a traveling stringline that mounts inboard of the screed end plate and bridges the screed extensions to reference both ahead and behind the screed.

Screeds

The BG-260C is offered with a choice of two screeds: the Extend-A-Mat 10-20B screed or the Pavemaster 10B screed. Paving packages are available for both screeds in widths to match the paving capability of the tractor.

Extend-A-Mat B Screed Options

Power Controls for Slope, Crown and Height include electric motor-driven gearboxes that provide fingertip operation of main screed crown, extender slope and extender height adjustments.

Screed Extensions are available in 305 mm (1') and 711 mm (2' 4") widths. Heat is by convection from the main screed. Vibration is provided on the 711 mm (2' 4") extension.

Cutoff Shoe Package consists of one 305 mm (1') and one 610 mm (2') cutoff shoe to reduce paving width in 76 mm (3") increments.

Bevel End Plates available to bevel mat edges for 38 mm (1.5"), 51 mm (2"), 64 mm (2.5"), and 76 mm (3") pavement thickness.

Berm Extensions available in right or left configurations. Lengths offered: 357 mm (14"), 508 mm (20"), and 660 mm (26"). All have 457 mm (18") screed plates. Slope is adjustable from 0 to 127 mm (5") high at outside edge. Wiring harness for extender control box supplied.

Pavemaster B Screed Options

Power Crown includes an electric motor-driven gearbox that provides fingertip control of main screed crown.

Screed Extensions available in 152 mm (6"), 305 mm (1'), 610 mm (2') widths with crown control, and 914 mm (3') widths. Heat and vibration available on 610 mm (2') and 914 mm (3') extensions.

Hydraulic Strike Offs are available to increase paving width to 1069 mm (3' 6") on either side of the screed. Power slope control of the strike-off moldboard and power adjustment of the moldboard height is standard. Paving width can be increased an additional 305 mm (1') with bolt-on strike off extensions.

QEHQ9399 (8-97)
Replaces QEHQ9357

© 1997 Caterpillar

Caterpillar follows a policy of continual product improvement.
For this reason, some material and specifications could change without notice.

