

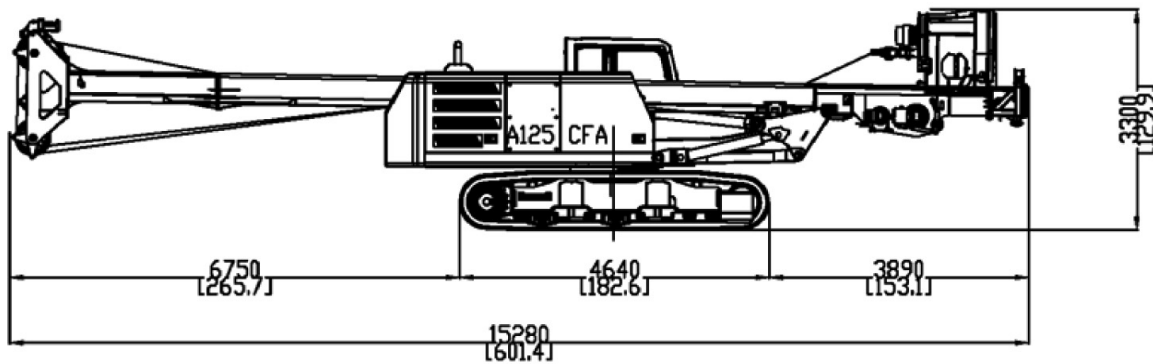

# A 125 CFA Powered by CAT



<b>Base</b>		IMT
Undercarriage length / widening range / shoe	mm	CAT 4660/2550 - 3650/600
	in	183/100 - 144/23,6
Engine type		CAT C 6.6 Acert
Power		120KW (163 HP) @1800 rpm
<b>Rotary</b>		
Installed torque	kNm	78
	lbf ft	57530
Working speed	rpm	8 - 40
<b>Winches</b>		
Main winch pull force	kN	123
	lbf	27655
Main winch speed	m/min	90
	ft/min	295
Main winch Cable diameter	mm	22
	in	/
Auxiliary winch pull force	kN	60
	lbf	13490
Auxiliary winch Speed	m/min	90
	ft/min	295
Auxiliary winch Cable diameter	mm	15
	in	/
Pull	in	2nd system
Extraction force	kN	246
	lbf	55305
<b>Mast</b>		
Mast raking forward		5°
Mast side raking		+5°
Mast raking backwards		15°
<b>Pile dimensions</b>		
Pile max. diameter	mm	1066
	in	42
Pile max. depth w/o auger extension	m	12,3
	ft	40,4
Pile max depth w/ auger extension	m	15,8
	ft	52
Operating weight (without augers)	t	32
	lbs	70550

# Measurements in working phase

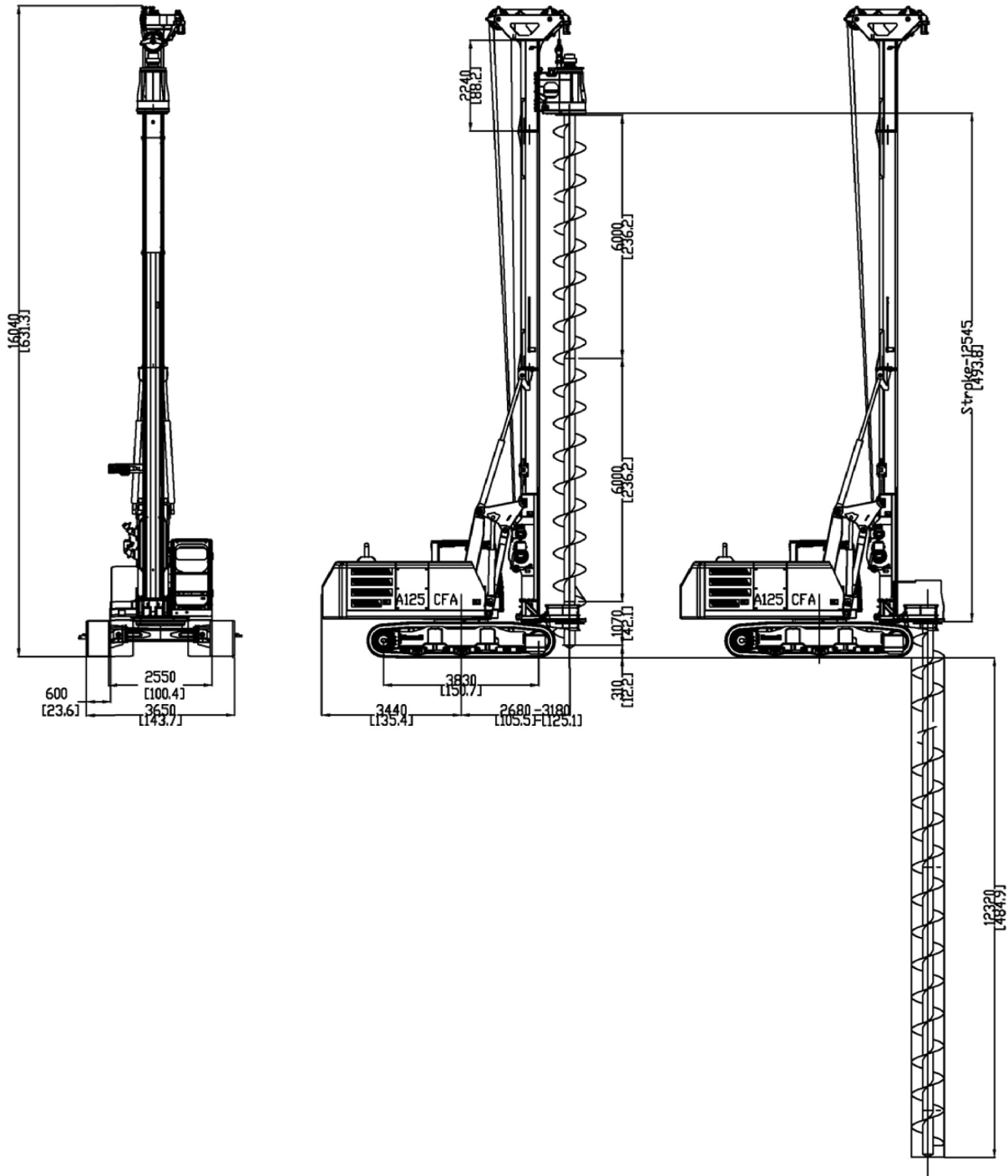

Purpose built Foundation Drilling Rig developed in cooperation with Caterpillar OEM Solutions Group

**IMT**<sup>®</sup>

INTERNATIONAL

Legal Headquarters:

Via dei Gracchi, 91 - 00192 Roma Italy

Offices and Plant:

Via d'Ancona, 39 - 60027 Osimo (An) - Italy

Tel. + 39 071 723341 r.a. - Fax + 39 071 7133352

[www.imtspa.com](http://www.imtspa.com) - [imt@imtspa.com](mailto:imt@imtspa.com)

All technical data are purely indicative and subject to change without notice.