

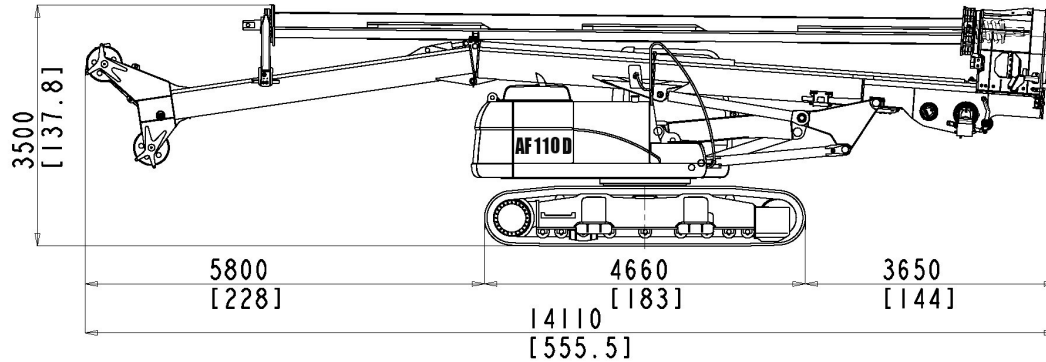

AF 110 D



Base		Caterpillar 319 D
Undercarriage length / widening range / shoe	mm	CAT 4660/2550 - 3650/600
	in	183/100 - 144/23,6
Engine type		CAT 3066 T
Power		97KW (130 HP) @1800 rpm
Rotary		
Installed torque	kNm	98
	lbf ft	72285
Working speed	rpm	7,5 - 32
Discharge speed	rpm	45 - 125
Winches		
Main winch pull force	kN	120
	lbf	26980
Main winch speed	m/min	90
	ft/min	295
Main winch Cable diameter	mm	22
	in	/
Auxiliary winch pull force	kN	60
	lbf	13490
Auxiliary winch Speed	m/min	90
	ft/min	295
Auxiliary winch Cable diameter	mm	15
	in	/
Crowd system		
Kelly crowd push	kN	100
	lbf	22485
Kelly crowd pull	kN	165
	lbf	37095
Stroke	mm	3325
	in	131
Mast		
Mast raking forward		5°
Mast side raking		+/- 5°
Mast raking backwards		15°
Pile max. diameter	mm	1500
	in	60
Kelly bar		
Standard		3/28 - 4/38
Options available		4/33 - 5/47
Operating Weight w/standard kelly bar	t (metric)	31
	lbs	68345

Measurements in working phase

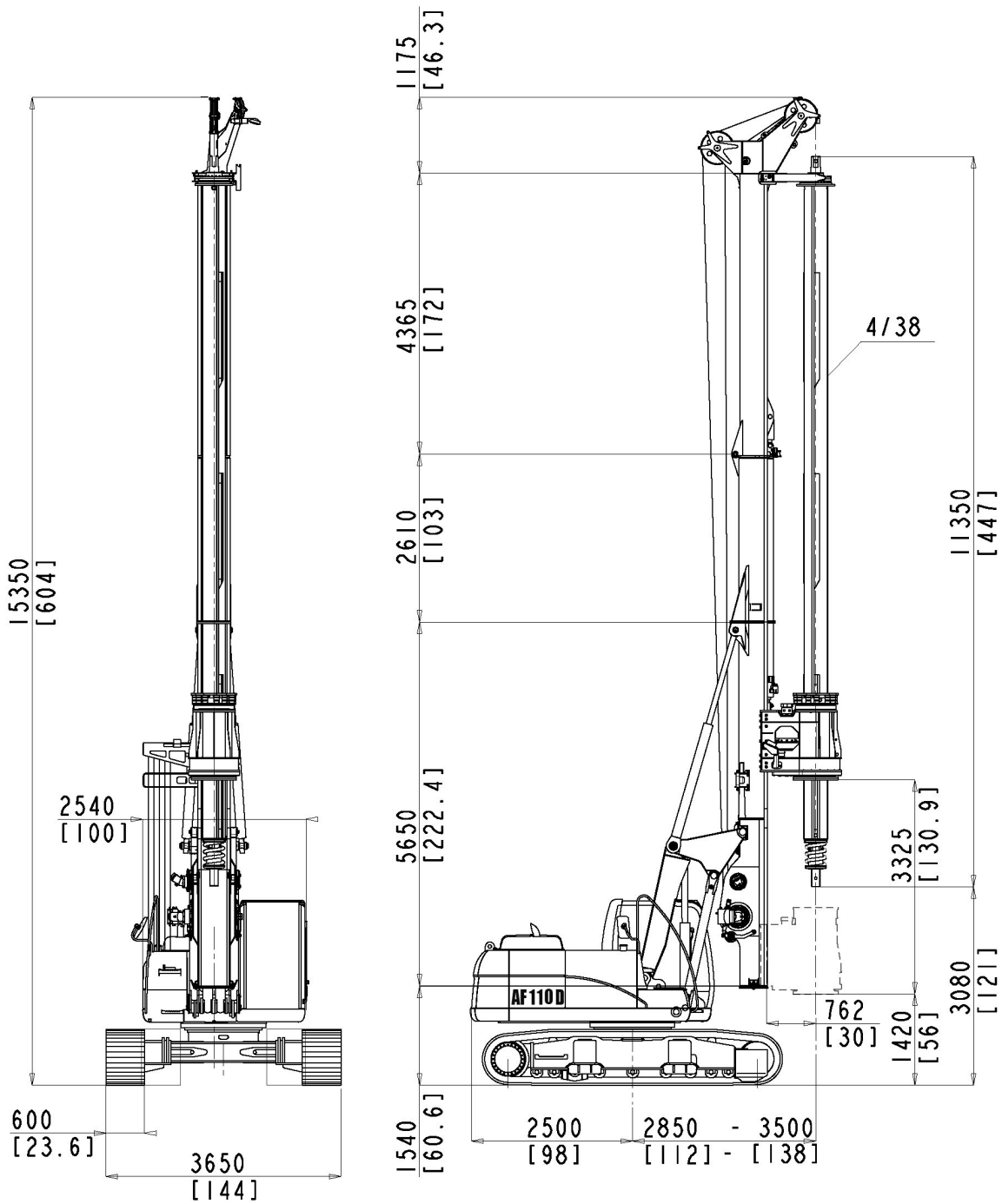

IMT INTERNATIONAL S.p.A.
Legal Headquarters:
 Via dei Gracchi, 91 - 00192 Roma Italy

Offices and Plant:
 Via d'Ancona, 39 - 60027 Osimo (An) - Italy
 Tel. + 39 071 723341 r.a.
 Fax + 39 071 7133352
<http://www.imtspa.com>
 e-mail: imt@imtspa.com

All technical data are purely indicative and subject to change without notice.