

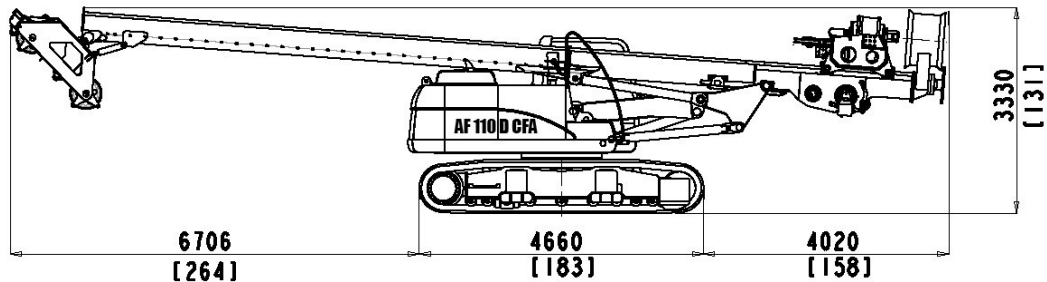

# AF 110 D CFA



<b>Base</b>		<b>Caterpillar 319 D</b>
<b>Undercarriage length / widening range / shoe</b>	mm	CAT 4660/2550 - 3650/600
	in	183/100 - 144/23,6
<b>Engine type</b>		CAT 3066 T
<b>Power</b>		97KW (130 HP) @1800 rpm
<b>Rotary</b>		
<b>Installed torque</b>	kNm	78
	lbf ft	57530
<b>Discharge speed</b>	rpm	8 - 40
<b>Pull in 2nd system</b>		
<b>Extraction force</b>	kN	240
	lbf	53954
<b>Winches</b>		
<b>Main winch pull force</b>	kN	120
	lbf	26980
<b>Main winch speed</b>	m/min	90
	ft/min	295
<b>Main winch Cable diameter</b>	mm	22
	in	/
<b>Auxiliary winch pull force</b>	kN	60
	lbf	13490
<b>Auxiliary winch Speed</b>	m/min	90
	ft/min	295
<b>Auxiliary winch Cable diameter</b>	mm	15
	in	/
<b>Mast</b>		
<b>Mast raking forward</b>		5°
<b>Mast side raking</b>		+/- 5°
<b>Mast raking backwards</b>		15°
<b>Pile max. diameter</b>	mm	1066
	in	42
<b>Operating Weight (without augers)</b>	t (metric)	29
	lbs	63935

# Measurements in working phase

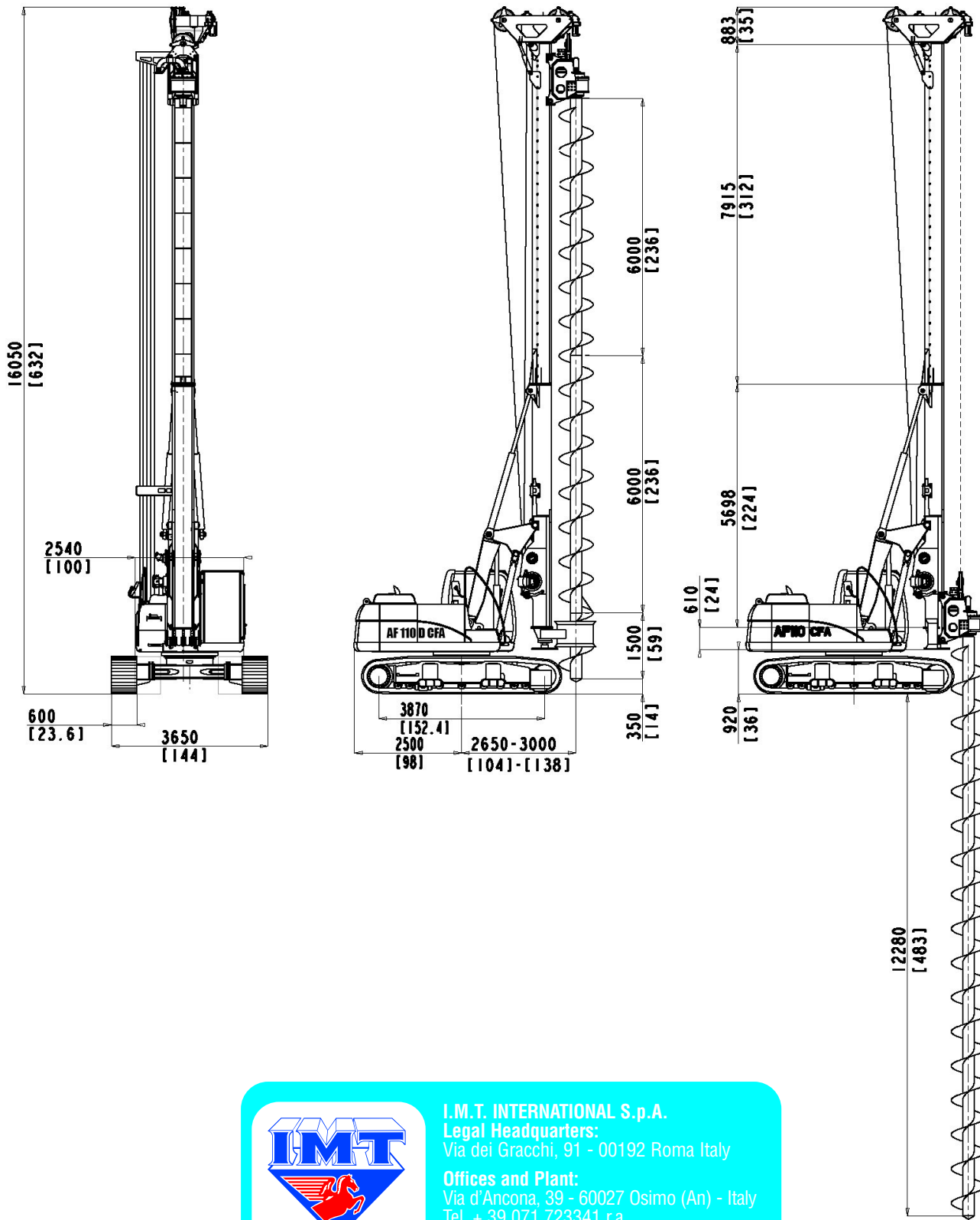

**I.M.T. INTERNATIONAL S.p.A.**  
**Legal Headquarters:**  
 Via dei Gracchi, 91 - 00192 Roma Italy

**Offices and Plant:**  
 Via d'Ancona, 39 - 60027 Osimo (An) - Italy  
 Tel. + 39 071 723341 r.a.  
 Fax + 39 071 7133352  
<http://www.imtspa.com>  
 e-mail: imt@imtspa.com

All technical data are purely indicative and subject to change without notice.