

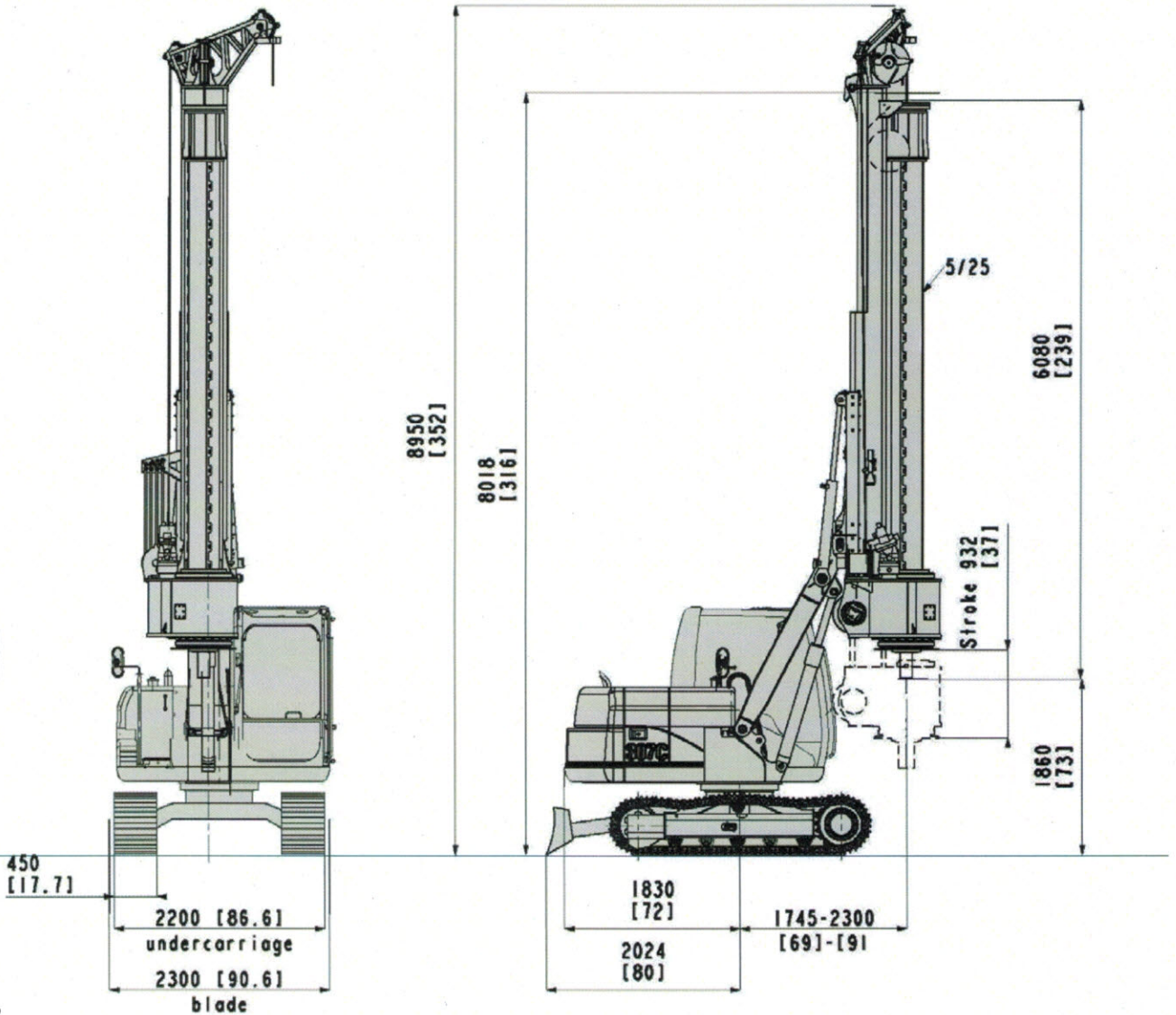

AF 35



Base		Caterpillar 307 D		Caterpillar 307 D	
Undercarriage length / widening range / shoe	mm	CAT 2760/2290/450	in	108/118/18	
Engine type		Mitsubishi 4M40 TL		Mitsubishi 4M40 TL	
Power		43KW (57,6 HP) @2600 rpm		43KW (57,6 HP) @2600 rpm	
Rotary					
Installed torque	kNm	35	lbf ft	25810	
Working speed	rpm	7 - 40	rpm	7 - 40	
Discharge speed	rpm	80	rpm	80	
Winches					
Main winch pull force	kN	55	lbf	12365	
Main winch speed	m/min	65	ft/min	213	
Main winch Cable diameter	mm	15	in	0,6	
Auxiliary winch pull force	kN	12	lbf	2698	
Auxiliary winch Speed	m/min	80	ft/min	263	
Auxiliary winch Cable diameter	mm	10	in	0,4	
Crowd system					
Kelly crowd push	kN	60	lbf	13488	
Kelly crowd pull	kN	110	lbf	24730	
Stroke	mm	932	in	37	
Mast					
Mast raking forward		5°		5°	
Mast side raking		±5°		±5°	
Mast raking backwards		15°		15°	
Pile max. diameter	mm	1200	in	47	
Kelly bar					
Standard		5/25		5/25	
Operating Weight w/standard kelly bar	t (metric)	12	lbs	26455	

All technical data are indicatives and subject to change without notice.

