

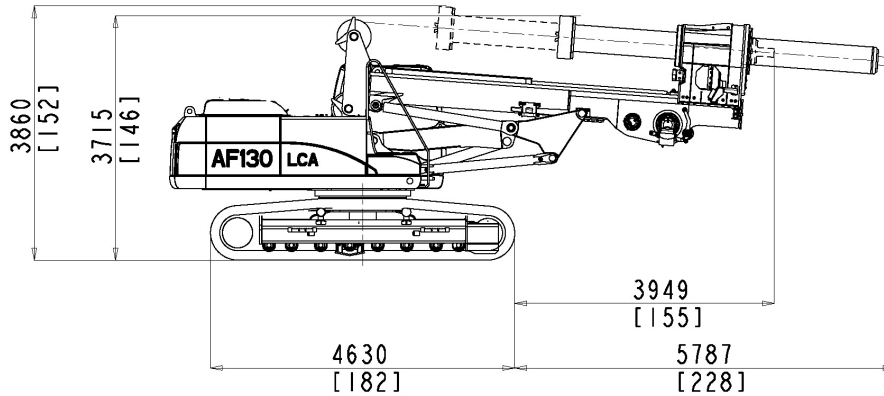

AF 130 LCA



Base		CAT 324 DLN
Undercarriage length / width / shoe	mm	4630/2990/600
	in	182/118/23,6
Engine type		CAT C7
Power		130 KW (174HP) @ 1800 rpm
Rotary		
Installed torque	kNm	117
	lbf ft	86295
Working speed	rpm	8.3 - 27
Discharge speed	rpm	50 - 120
Winches		
Main winch pull force	kN	120
	lbf	26980
Main winch speed	m/min	90
	ft/min	295
Main winch Cable diameter	mm	22
	in	/
Auxiliary winch pull force	kN	60
	lbf	13490
Auxiliary winch Speed	m/min	90
	ft/min	295
Auxiliary winch Cable diameter	mm	15
	in	/
Crowd system		
Kelly crowd push	kN	100
	lbf	22485
Kelly crowd pull	kN	165
	lbf	37095
Stroke	mm	2000
	in	79
Mast		
Mast raking forward		5°
Mast side raking		+/- 5°
Mast raking backwards		15°
Pile max. diameter	mm	1500
	in	60
Kelly bar		
Standard for LCA		5/20
Operating Weight w/standard kelly bar	t (metric)	31
	lbs	68345

Measurements in working phase

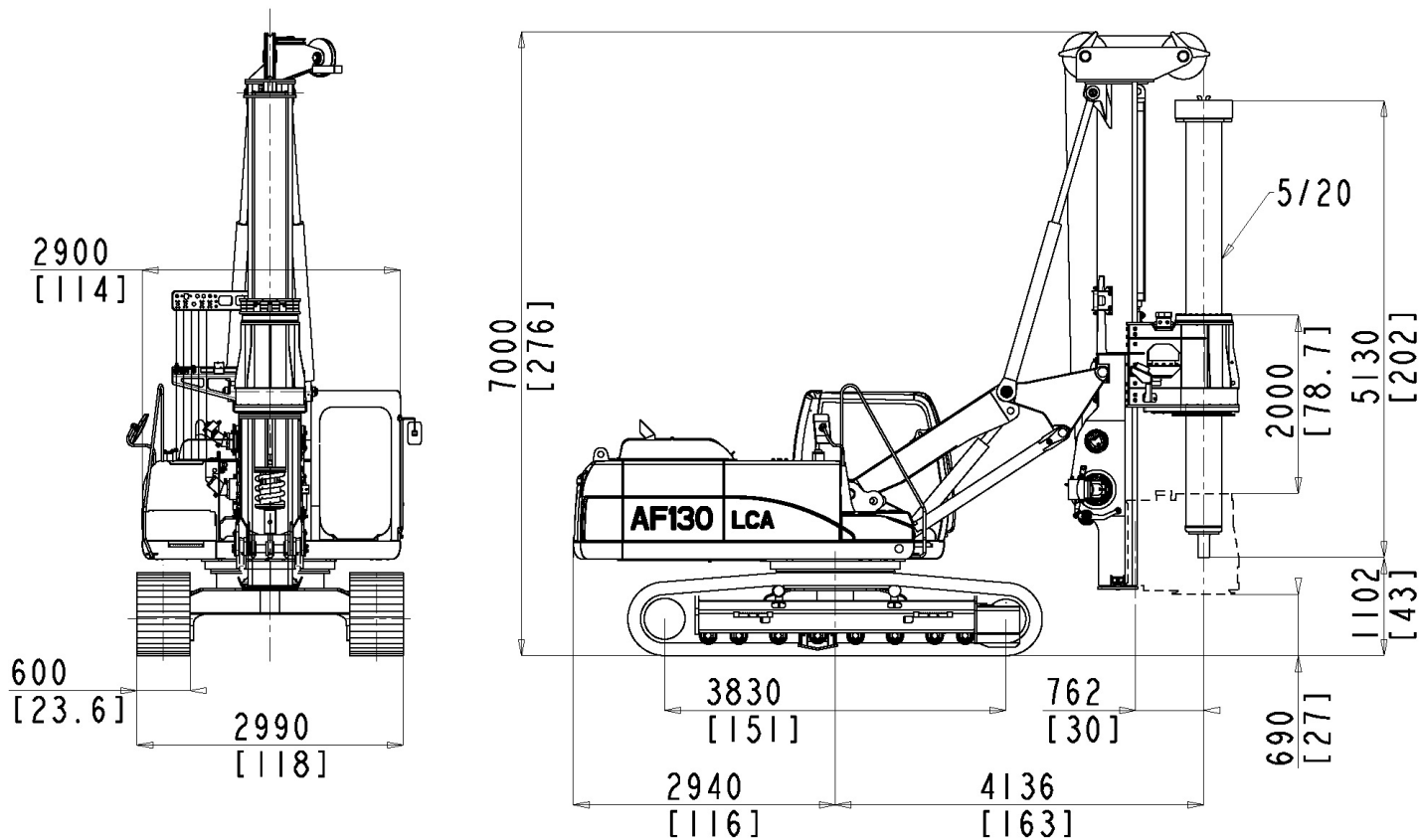

I.M.T. INTERNATIONAL S.p.A.

Legal Headquarters:

Via dei Gracchi, 91 - 00192 Roma Italy

Offices and Plant:

Via d'Ancona, 39 - 60027 Osimo (An) - Italy

Tel. + 39 071 723341 r.a.

Fax + 39 071 7133352

<http://www.imtspa.com>

e-mail: imt@imtspa.com

All technical data are purely indicative and subject to change without notice.