

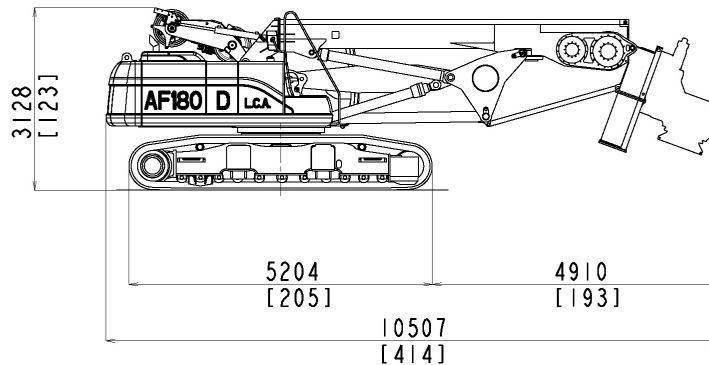

AF 180 D LCA



Base		CAT 325D HHP
Undercarriage length/width/shoe	mm	5210/3000 - 4300/800
	in	205/118-169/31,5
Engine type		CAT C 7
Power		187 KW (250 HP) @1800 rpm
Rotary		
Installed torque	kNm	205
	lbf ft	151205
Working speed	rpm	7 - 25
Discharge speed	rpm	40 - 120
Winches		
Main winch pull force	kN	180
	lbf	40470
Main winch speed	m/min	85
	ft/min	279
Main winch Cable diameter	mm	26
	in	/
Auxiliary winch pull force	kN	80
	lbf	17985
Auxiliary winch speed	m/min	85
	ft/min	279
Auxiliary winch Cable diameter	mm	18
	in	/
Crowd system		
Kelly crowd push	kN	180
	lbf	40470
Kelly crowd pull	kN	200
	lbf	44965
Stroke	mm	1860
	in	73
Mast		
Mast raking forward		5°
Mast side raking		+/- 8°
Mast raking backwards		15°
Pile max. diameter (mm)	mm	1800
	in	71
Kelly bar		
Standard		4/20
Options available		6/31
"Operating Weight w/standard kelly bar"	t (metric)	48
	lbs	105825

Measurements in working phase

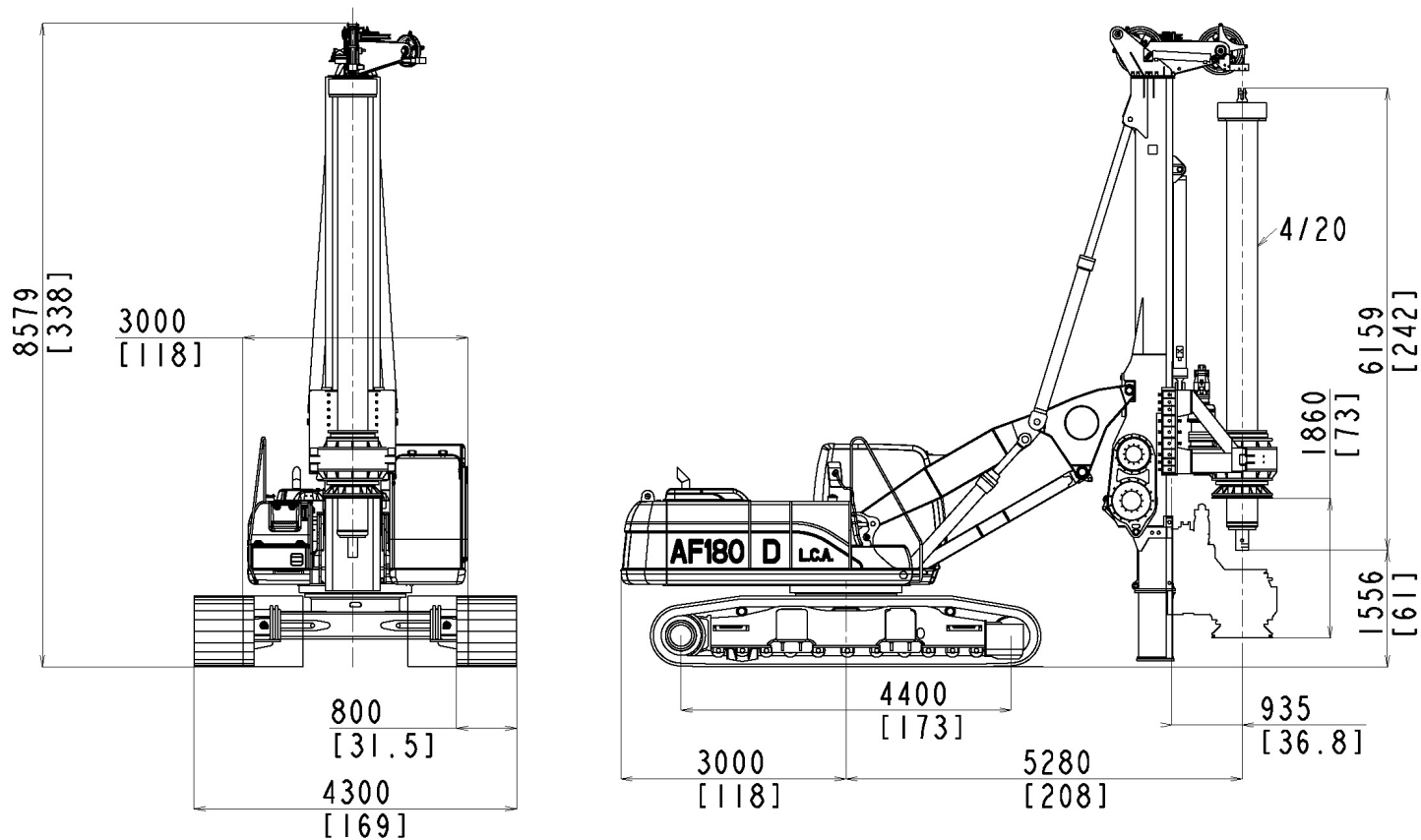

I.M.T. INTERNATIONAL S.p.A.

Legal Headquarters:

Via dei Gracchi, 91 - 00192 Roma Italy

Offices and Plant:

Via d'Ancona, 39 - 60027 Osimo (An) - Italy

Tel. + 39 071 723341 r.a.

Fax + 39 071 7133352

<http://www.imtspa.com>

e-mail: imt@imtspa.com

All technical data are purely indicative and subject to change without notice.