

BG-245C

Track
Asphalt Paver

CAT[®]



Operating weight with Extend-A-Mat B Screed	19 250 kg	43,860 lb
Operating weight with Pavemaster B Screed	17 620 kg	38,900 lb
Hopper Capacity	6,1 cu m	215 cu ft
Standard Paving Width	3048 mm	10'
Paving Range with Extend-A-Mat B Screed	2438 - 7366 mm	8 - 24' 2''
Paving Range with Pavemaster B Screed	2438 - 9144 mm	8 - 30'

Caterpillar® Diesel Engine

Model 3116TA is a high-tech six cylinder diesel engine designed to provide quiet performance, high reliability, easy servicing and excellent fuel economy.

Turbocharged for top performance and efficiency especially at high altitudes.

Transverse engine mounting provides better cooling performance and greater accessibility for service.

Low sound emission achieves compliance with major regulatory rules according to Caterpillar sound pad test results.

Heavy duty unit-type fuel injection and low pressure fuel lines minimize opportunity for fuel leaks.

Intake manifold heater preheats incoming air for quick cold weather starting.

Meets EPA/CARB emissions engine regulations.

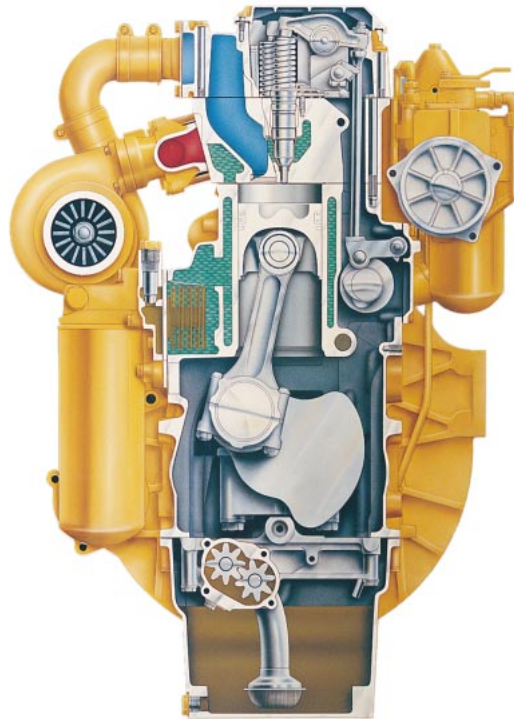

Hydrostatic Drive System

Efficient hydraulic drive system eliminates chains and other mechanical linkages between diesel engine and final drive components.

Closed-loop hydrostatic propel system provides efficient, low-maintenance operation.

Speed control system maintains preset paving speeds throughout a job.

Propulsion controller provides accurate control of steering and propulsion systems.

Decel pedal provides foot control of propel speed freeing operator to control other paving functions.

Dual path steering system utilizes steering wheel for simplified operation.

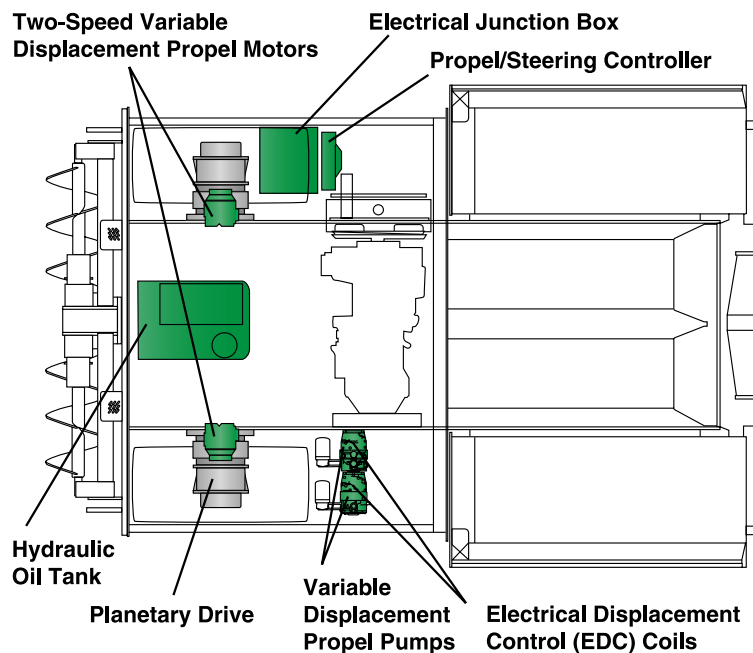

Operator's Station

Single operator's station designed for comfort and optimum efficiency.

Single operator's station slides from side to side and includes fully equipped instrument console and steering wheel with lockable cover.

Dual-slide feature allows the seat to be slid from side to side and front to back on the pedestal frame, enhancing visibility.

Operator's seat pivots 152 mm (6") to the left or right to further enhance operator visibility.

Low-mounted engine provides unobstructed forward visibility.



Control Console

Full instrumentation package keeps operator informed of all major systems status.

International symbols and functional word descriptions are shown for all controls.

Gauges are analog type for quick interpretation.

Warning lights illuminate and horn alert operator to:

- High hydraulic oil temperature;
- Low hydraulic oil level;
- Low engine oil pressure; or
- High engine coolant temperature.

Electrical wiring is protected by an articulated vinyl enclosure.

Speed control allows the operator to dial a maximum paving speed. Once set, the paver returns to the preset speed when propel lever is in full forward position.



Exclusive Feeder/Auger Control System

Precise mix delivery through the most advanced material handling system.

Left and right feeders and left and right augers are all controlled independently, eliminating the need for feeder gates.

Once the feeder speeds are set, the ratio of feeder speed to the maximum auger speed is automatically maintained by the material handling controller, regardless of propel rate or paving widths.

To control mix delivery, the operator sets a speed rate for each feeder that will maintain the desired mix level in the left and right auger chambers.

Component wear is reduced because full feeders run at slower speeds.

Potential for mix segregation is minimized because head of material remains constant.

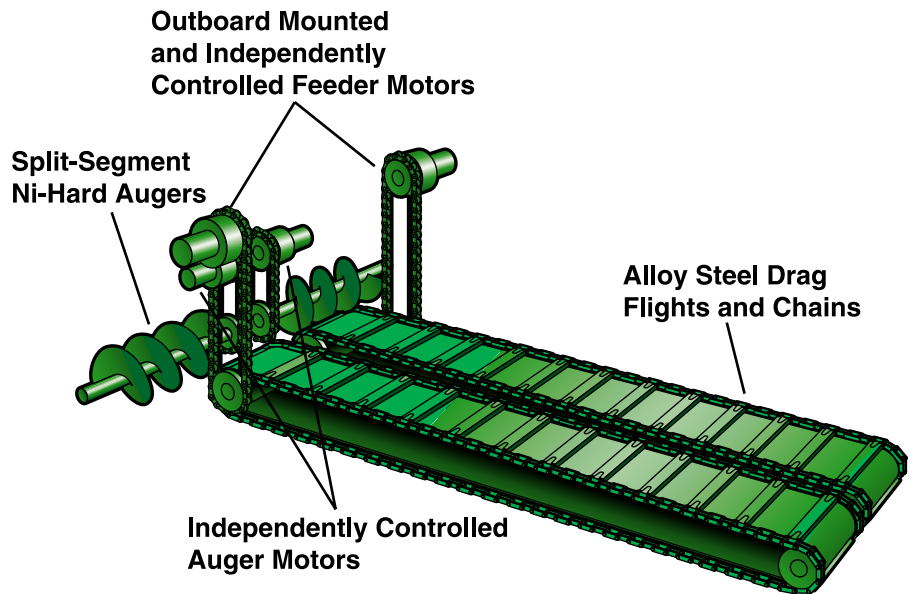

Gateless Feeders

Slower running feeders reduce wear and segregation.

Gateless feeders always run full of mix regardless of the speed required to fill the auger chamber.

When changes in feeder speed are needed, delivery of mix to the augers is immediate.

Drag pans are constructed with abrasion resistant, heat treated steel.

Feeder flight bars are forged steel and pinned to two strands of roller bushed chain.

Potential for segregation is reduced with slower running feeders, especially when working with large stone mixes.



Adjustable Height Auger Assembly

Promotes mat consistency and minimizes segregation.

Auger assembly can be hydraulically adjusted 171 mm (6.75").

When working with larger stone mixes, segregation can often be eliminated or minimized by raising the augers to allow mix to flow unrestricted under the auger assembly.

Ability to raise the auger assembly simplifies loading and unloading from a transport vehicle.

Dual lift cylinders provide a stable position for the augers, enhancing mat quality.

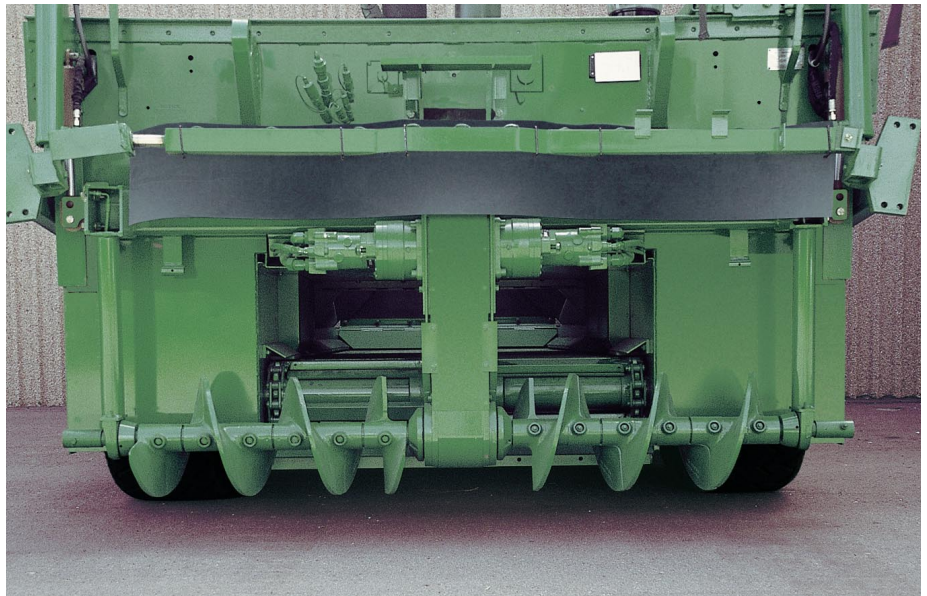

Feeder Design Improves Mix Flow

Tunnel construction helps minimize segregation.

Distance between the two feeders is significantly reduced because the auger drive assembly is not part of the tractor.

Narrow distance between feeders allows flow from both feeders to blend together easily as they discharge into the auger cavity. This design helps minimize segregation.

Since the auger case is not attached to the tractor, voids under the chain case are eliminated.



Undercarriage

Track system designed for superior ride quality.

Computer determined track roller placement and special quad roller rear bogies achieve smoother ride.

Cat D3 track rails including sealed tracks with split master link for dependable, low maintenance performance.

Automatic track tensioning system for lower maintenance, fewer adjustments.

Increased tractive effort with standard rubber track pads. Two bolt attachment system for easy pad replacement.



Serviceability

Simplified service means more paving and less maintenance time.

Large swing-open doors and panels provide access to all service areas.

Transverse engine mounting provides ground-level access to hydraulic pumps and engine cooling system.

Color coded and numbered wiring system simplifies troubleshooting electrical systems.

Lubrication fittings are clustered for quick service.

Propulsion and material controllers provide diagnostic capability for troubleshooting hydraulic and electrical systems.

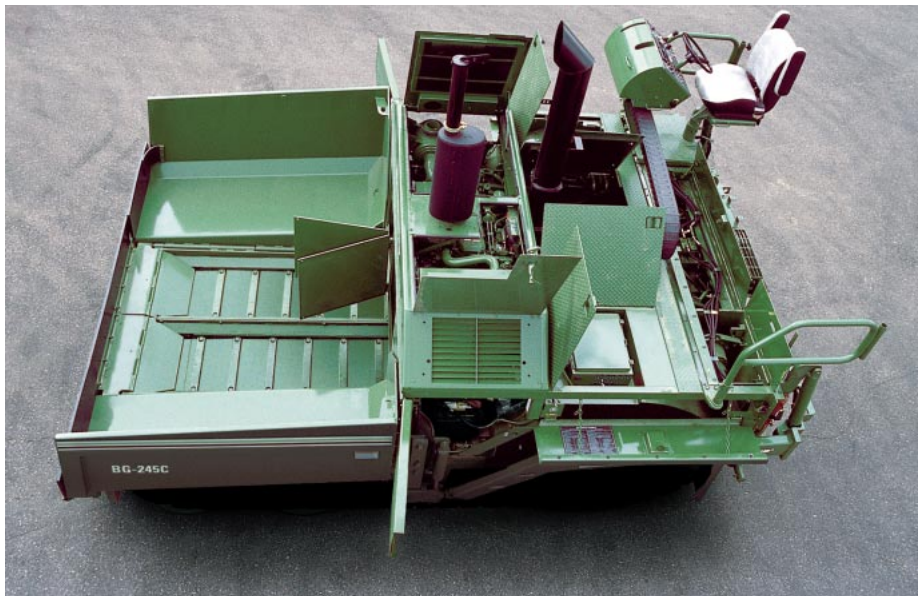

Extend-A-Mat 10-20B Screed

Variable width, power extending screed increases productivity and lowers operating costs.

Model 10-20B paves from 3,04 m (10') to 5,94 m (19' 6"). With cutoff shoes and extensions, range is 2,44 m (8') to 7,37 m (24' 2").

Mat thickness and crown are accurately controlled at any paving width.

Extender sloping to 14% down and to 2% above horizontal is accomplished on-the-go.

Four fuel oil burners with electric ignition provide even screed plate heating. Each burner provides 110,000 BTU. Insulated combustion chamber provides even heat distribution.

Triangular configuration of extender tubes and frame member improves torsional resistance.



Extend-A-Mat Screed shown with BG-2455C Asphalt Paver.

Pavemaster 10B Screed

Heavy-duty conventional fixed-width screed provides simple economical operation.

Model 10B has a fixed paving width of 3,04 m (10'). With cutoff shoes and extensions it's paving range is from 2,44 m (8') to 9,14 m (30').

Two fuel oil burners with electric ignition provide even screed plate heating. Insulated combustion chambers provide even heat distribution.



Engine

Cat 3116TA turbocharged, aftercooled, four stroke/cycle six cylinder diesel engine. Meets EPA and CARB emissions engine regulations.

Ratings at 2200 RPM	kW	hp
Gross power	130	174
Net power	118	158

Ratings of Caterpillar machine engines are based on standard air conditions of 25°C (77°F) and 99 kPa (29.32") Hg dry barometer. Power is based on using 35° API gravity fuel having an LHV of 42,780 kJ/kg (18,390 Btu/lb) when used at 30°C (86°F) [ref. a fuel density of 838.9 g/L (7.001 lb/U.S. gal)]. Net power advertised is the power available at the flywheel when the engine is equipped with fan, air cleaner, muffler and alternator.

The following ratings apply at 2200 RPM when tested under the specified standard conditions for the specified standard:

Net Power	kW	hp
ISO 9249	118	158
SAE J1349 (JAN)90	118	158
EEC 80/1269	118	158

Dimensions

Bore	105 mm	4.12"
Stroke	127 mm	5.0"
Displacement	6,6 L	403 cu in

Drive System

The drive is via two dual path hydrostatic pumps and variable displacement motors. Pumps are infinitely variable with electric dual controls for steering and speed. Motors have two displacement settings for two speed ranges.

Forward and reverse speed ranges		
Paving	0 - 60,1 mpm	0 - 200 fpm
Travel	0 - 8 kmph	0 - 5 mph

Ventilation System

Ventilation System helps remove asphalt fumes from the auger chamber area. The system consists of a collection hood over the auger chamber area, hydraulic-driven exhaust fan, ducts and exhaust stack to vent asphalt fumes away from the operator and screed areas.

Brakes

Service braking system: Closed loop hydrostatic system provides dynamic braking. Parking brake system: Spring-applied/hydraulically released brake on track drives. Parking brake actuated by hand control at the operator's station or automatically when engine is shut down and whenever power switch is in off mode. Brake systems meet SAE recommended practice J2118 Feb94.

Sound

The engine compartment is lined with noise-suppression insulation to reduce ambient sound levels.

Steering

Steering is full-power via an automotive-type steering wheel at the moveable operator's station. Electric-over-hydraulic dual path differential steering assures precise machine control. Steering commands are independent of propel speed.

Three steering modes are selectable at the operator's console. When in the Pave or Travel mode, steering range is electrically reduced to minimize abrupt steering movements. Minimum turning radius, measured at the inside track when in Pave mode, is 914 mm (3'). When in Maneuver mode, steering system is at full range, allowing the paver to pivot-turn by counter-rotating the tracks.

Electrical

The 24-volt electrical system utilizing two 12-volt batteries and a 55-amp alternator. The wiring is color coded and numbered for easy servicing. All wiring is protected by vinyl coated nylon braiding for greater durability. All circuits tie to a main junction box with circuit breakers that can be reset.

Frame

H-section mainframe construction with integral tunnel cover. Frame fabricated from heavy gauge steel plate. Tunnel cover is 9,5 mm (0.375") thick, the feeder base is 15,8 mm (0.6250") thick and the side plates are 19 mm (0.750") thick.

Operator's Station

A single operator's station slides from one side of paver to the other. Dual-slide allows the seat to be moved from side to side and front to back on the pedestal frame, enhancing visibility. Operator's seat swivels 152 mm (6") to the left or right to further improve operator visibility. Deluxe seat with arm rests has heat-reflective cover. Station has a complete instrument console and an adjustable seat with seat belt. All console wiring is protected by an articulated vinyl enclosure.

Operator's Controls

The single lockable operator's console has: steering wheel; decel pedal; engine throttle fast/slow switch; auger raise/lower switch; hopper raise/lower switch; left and right feeder auto/off/man switch; left and right feeder/auger ratio control; horn button; propel forward/reverse lever; pave/travel/maneuver mode switch; maximum speed control dial; engine start switch; parking brake switch; screed vibrator on/off switch; screed lift up/down switch; extender in/out switch; screed counterbalance on/off switch.

Instrumentation

Gauges are analog-type for easier reading and quicker interpretation. Instrumentation on the operator's console includes: Tachometer/foot-per-minute meter with hourmeter; hydraulic oil filter condition indicator light; system warning lights for high hydraulic oil temperature, low hydraulic oil level, low engine oil pressure, and high coolant temperature; battery charging light; engine temperature gauge; fuel level gauge; engine oil pressure gauge; hydraulic oil temperature gauge; propel system status light; and feeder system status light.

The operator is also alerted by a warning horn whenever the following conditions exist: high hydraulic oil temperature; low hydraulic oil level; low engine oil pressure; or high coolant temperature.

Suspension

Undercarriage consists of four 241 mm (9.5") diameter track rollers, a special rear, four roller (152 mm (6") diameter bogey, and two (152 mm (6") diameter single roller return idlers per side. Rollers are bogied in pairs and each pair is articulated for optimum leveling capability. Rollers ride on Caterpillar D3 track rail. Track rails are sealed type and have a split master link for quick track removal and installation. Tracks are fitted with 127 mm (5") by 356 mm (14") rubber bonded track pads.

Track tensioning is provided by a parallel link swing arm design that provides constant hydraulic pressure. Track tension is maintained without manual adjustment. Recoil forces are controlled by check and relief valves.

Feeders and Augers

Dual feeders and augers are controlled independently through variable speed drives. A material feed controller provides ratio control of augers and feeders. Paddle sensors control the feeders/augers to provide the exact volume of material required. Ratio adjustment eliminates the need for feeder gates. The system allows feeders to run full at lower speeds. Reduced component wear, lower horsepower required and less opportunity for segregation can be expected.

Right and left feeder/auger operate independently of each other. Feeder drive and drive chains are located outside the mainframe for easy accessibility.

Feeder flights are constructed of heavy-duty bushed roller chain with forged steel flight bars sliding over replaceable, abrasion resistant drag pans with 360-440 Brinell hardness.

Long life auger system consists of segmented, 406 mm (16") diameter, cast Ni-Hard steel hemi-screw augers. Auger and hanger bearings have built-in steel shields for greater protection. Bearing lube points are remote mounted for accessibility.

Hydraulic Oil Filtration

Propel pumps have 10-micron integral charge loop filtration and 7 micron reservoir return filtration. The material feed system (feeders/augers) has 5-micron integral charge loop filtration. Vibrator pump has 100-mesh suction strainer on the inlet. The auxiliary pump has a 100-mesh suction strainer on the inlet.

Hopper

Power hopper dumping, controlled from operator's console. With heavy duty flashing prevents material spillage.

Capacity
6,1 cu m (215 cu ft)
Truck Entry Width
3182 mm (10' 5")
Truck Dump Height
610 mm (24")

Service Refill Capacities

	Liters	Gallons
Fuel Tank	284	75
Hydraulic Oil Tank	151,4	40
Cooling System	31,5	8.3

Weights (approximate)

Tractor	16 015 kg (35,300 lb)
With Extend-A-Mat 10-20B Screenshot	19 250 kg (42,500 lb)
With Pavemaster 10B Screenshot	17 620 kg (38,900 lb)

Dimensions

	Extend-A-Mat B Screenshot	Pavemaster B Screenshot
A Length with push roller with truck hitch	6579 mm (21' 7") 7061 mm (23' 2")	6096 mm (20' 0") 6579 mm (21' 7")
B Operating width	3327 mm (10' 11")	3327 mm (10' 11")
C Overall height	3378 mm (11' 1")	3378 mm (11' 1")
D Transport width (hoppers raised) with end gates without end gates	3327 mm (10' 11") 3048 mm (10' 0")	3327 mm (10' 11") 3048 mm (10' 0")
E Transport height (muffler removed)	2769 mm (9' 1")	2769 mm (9' 1")
F Track contact length	3048 mm (10')	3048 mm (10')

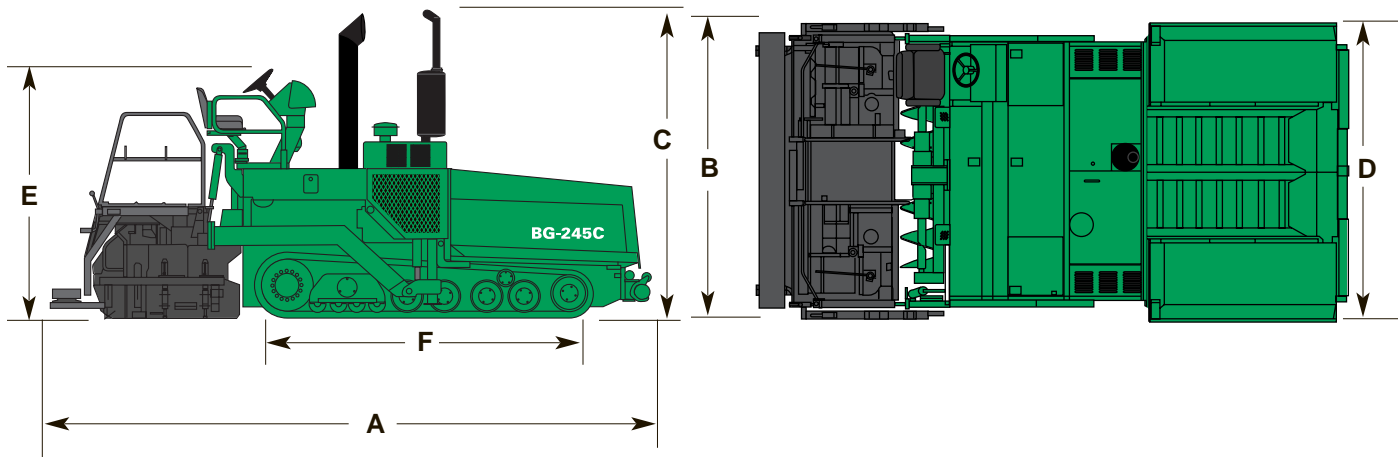

Optional Equipment

Tractor

Oscillating Push Rollers provide contact point between paver and truck to center load and assist steering.

Truck Hitch provides positive locking between paver and truck when unloading trucks. Hydraulically actuated from the operator's console.

Lighting Package consists of four variable position sealed beam flood lights, two mounted forward and two mounted to the rear, illuminate work area.

Hazard Light consists of rotating amber beacon and mount, increasing visibility during paving or roading of paver.

Auxiliary Fuel Tank provides an additional 114 L (30 gal) fuel capacity.

6 kW or 8 kW Generators are hydraulically driven through a load-sensing, pressure-compensating pump. The hydraulically driven pump provides quiet operation, and the load-sensing pump and a control manifold maintain constant electrical frequency at both high and low idle. All outlets are GFCI protected.

Deflector Kit enhances material flow on tough mixes, helping prevent segregation.

High Ambient Cooling Kit is a remote-mounted hydraulic oil cooler that enhances cooling capacity in extreme ambient temperatures.

Controls and References

Automatic Grade and Slope Controls provide full proportional control for both longitudinal grade and transverse slope.

Basic package includes two screed mounted control units, slope sensor and mounting hardware. Option includes wand or sonic grade sensors.

Auger/Feeder Control Sensors monitor material level in front of screed and proportionally control material feed to maintain desired level of mix ahead of screed. This system fits paddle or sonic sensors.

Rigid Ski is a triangular truss rigid ski that rides directly on the pavement. Grade sensor can reference directly off ski or a stringline mounted to the ski. Available in 9,1 m (30') and 12,2 m (40') lengths.

Outboard Leveler is a traveling multi-foot outboard mounted grade reference that provides a mean average on the surface on which it is operating. Available in 9,1 m (30') and 12,2 m (40') lengths.

Inboard Leveler is a traveling stringline with many of the features of the Outboard Leveler. Mounts ahead of the screed extensions and inboard of the screed end plate. Used when outboard referencing is not practical.

Mobile Stringline consists of a two-section arrangement of beams and sleds that mount outboard of the screed. Package includes beams, sleds, stringline, pivot pins, brackets and attaching hardware.

Fore 'N Aft Leveler is a traveling stringline that mounts inboard of the screed end plate and bridges the screed extensions to reference both ahead and behind the screed.

Screeds

The BG-245C is offered with a choice of two screeds: the Extend-A-Mat 10-20B Screed and the Pavemaster 10B Screed. Paving packages are available for both screeds in widths to match the paving capability of the tractor.

Extend-A-Mat B Screed Options

Automatic Burner System thermostatically controls the screed plate heating system, helping maintain a consistent temperature.

Power Controls for Slope, Crown and Height include electric motor-driven gearboxes that provide fingertip operation of main screed crown, extender slope and extender height adjustments.

Screed Extensions are available in 305 mm (1') and 711 mm (2' 4") widths. Heat is by convection from the main screed. Vibration is provided on the 711 mm (2' 4") extension.

Cutoff Shoe Package consists of one 305 mm (1') and one 610 mm (2') cutoff shoe to reduce paving width in 76 mm (3") increments.

Bevel End Plates available to bevel mat edges for 38 mm (1.5"), 51 mm (2"), 64 mm (2.5"), and 76 mm (3") pavement thickness.

Berm Extensions available in right or left configurations. Lengths offered: 357 mm (14"), 508 mm (20"), and 660 mm (26"). All have 457 mm (18") screed plates. Slope is adjustable from 0 to 127 mm (5") high at outside edge. Wiring harness for extender control box supplied.

Pavemaster B Screed Options

Power Crown includes an electric motor-driven gearbox that provides fingertip control of main screed crown.

Screed Extensions available in 152 mm (6"), 305 mm (1'), 610 mm (2') widths with crowning, and 914 mm (3') widths. Heat and vibration available on 610 mm (2') and 914 mm (3') extensions.

QEHQ9676 (1-00)
Replaces QEHQ9597

© 2000 Caterpillar

Caterpillar follows a policy of continual product improvement.
For this reason, some material and specifications could change without notice.

