

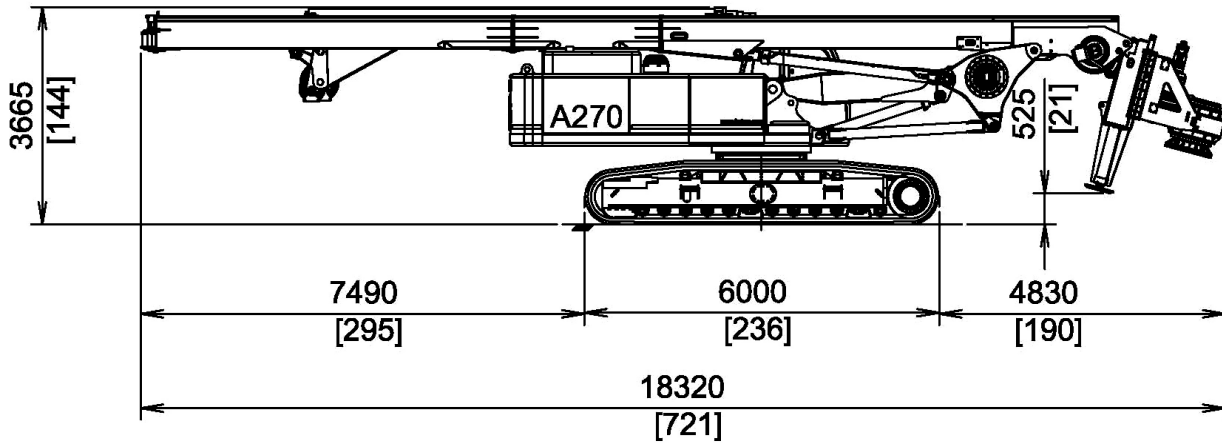

# A 270



<b>Base</b>		IMT
Undercarriage length / widening range / shoe	mm	6000/2900 - 4250/800
	in	236/114 - 167/31,5
Engine type		CAT C13
Power	Kw	310 (422HP) @ 1800rpm
<b>Rotary</b>		
Installed torque	kNm	275
	lbf ft	202830
Working speed	rpm	8 - 30
Discharge speed	rpm	48 - 115
<b>Winches</b>		
Main winch pull force	kN	250
	lbf	56205
Main winch speed	m/min	73
	ft/min	240
Main winch Cable diameter	mm	28
	in	/
Auxiliary winch pull force	kN	120
	lbf	26980
Auxiliary winch Speed diameter	m/min	80
	ft/min	262
Auxiliary winch Cable diameter	mm	22
	in	/
<b>Crowd system</b>		
Kelly crowd push	kN	300
Kelly crowd pull	lbf	67445
	kN	390
Stroke	lbf	87680
	mm	6400
	in	252
<b>Mast</b>		
Mast raking forward		5°
Mast side raking		+8°
Mast raking backwards		15°
Pile max. diameter	mm	2000
	in	79
<b>Kelly bar</b>		
Standard		4/46
Options available		4/35 - 4/52 - 5/50 - 5/66 - 5/70
Operating Weight w/standard kelly bar	t (metric)	73,5
	lbs	164640

# Measurements in working phase

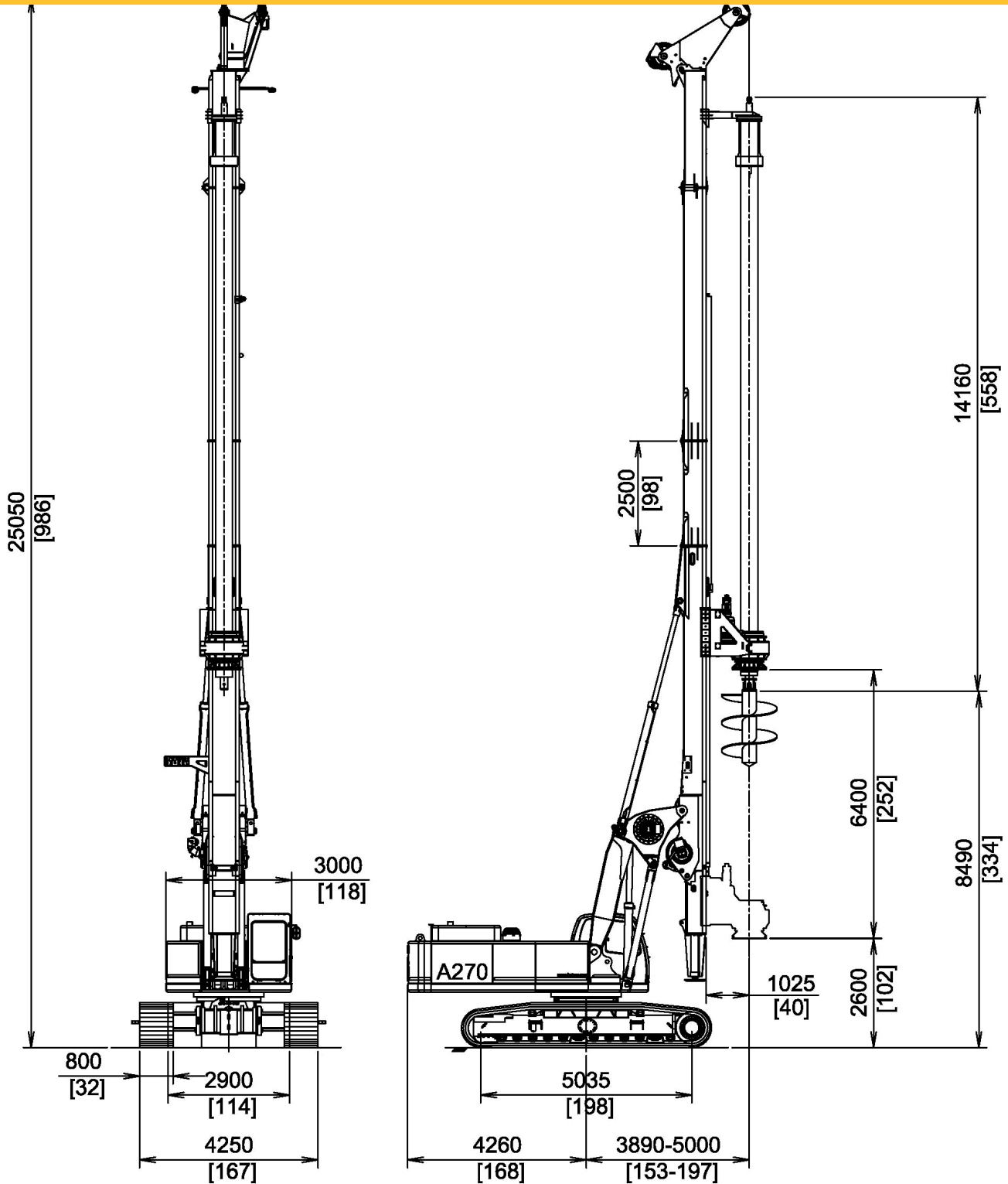

**IMT**  
INTERNATIONAL

Legal Headquarters:

Via dei Gracchi, 91 - 00192 Roma Italy

Offices and Plant:

Via d'Ancona, 39 - 60027 Osimo (An) - Italy

Tel. + 39 071 723341 r.a. - Fax + 39 071 7133352

www.imtspa.com - imt@imtspa.com

All technical data are purely indicative and subject to change without notice.